

HOFMANN

Gastronomiegeräte

2016
KATALOG



„Wir sind zusammen stark!“



Wir sind telefonisch erreichbar:

Mo-Fr: 08:00-18:00 Uhr
Sa: 08:00-15:00 Uhr



🇩🇪 HOFMANN: IHR PARTNER FÜR HOTEL- UND GASTSTÄTTENGEWERBE UND CATERING GERÄTE

Unsere langjährige Erfahrung und Zuverlässigkeit hat es uns, als mittelständiges Unternehmen, im globalen Markt ermöglicht, im professionellen Gastronomiebereich Anker zu setzen.

Wir beliefern unsere Kunden mit Präzision, aus ganz Deutschland und Mitteleuropa.

Ein breites Produktsortiment von Eco-Serien bis hin zu Professionellen-Serien ermöglicht unseren Partnern ein großes Angebot an Gastronomiegeräten.

Je nach Verwendung finden unsere Produkte Gebrauch in Pizzerien, Restaurants, Gaststätten, Sportkantinen, Betriebsrestaurants usw.

Neben dem schnellen Service ist die Kundenzufriedenheit unsere höchste Priorität.

Das ganze Team bemüht sich, jeden einzelnen Kunden individuell und fachgerecht zu beraten und in jeder Hinsicht schnelle und zufriedenstellende Lösungen zu bieten.

Es ist unser Ziel, durch ein breites Fachwissen, starke Flexibilität, aktuelle Wettbewerbspreise, schnelle Lieferzeiten und hohe Qualität, uns zu unterscheiden.

Verbesserungsvorschläge nehmen wir im Sinne einer stetigen Entwicklung jederzeit gerne entgegen. Unser Team steht Ihnen für Fragen und Antworten gerne zur Verfügung, denn Ihre Zufriedenheit ist unser Erfolg.

🇹🇷 HOFMANN: OTEL, RESTAURANT ISLERI VE YIYECEK ICECEK HİZMETLERİ İÇİN SİZİN ORTAGINIZ

Uzun yıllara dayanan tecrübe ve güven ile orta ölçekli bir şirket olarak global piyasada, profesyonel olarak endüstriyel mutfak alanında kök salmayı sağlamıştır.

Tüm Almanya ve orta Avrupa'da bulunan müşterilerimize özenle hizmet sağlamaktayız.

Eco-Seri ve Profesyonel-Seri içeren geniş ürün yelpazemiz ile partnerlerimize büyük bir seçim olanağı tanımaktayız.

Ürünlerimiz kullanım alanına göre Pizzacılar, Restoranlar, Kantinler, İşletme mutfakları vb. alanlarda yer almaktadır.

Hızlı servisin yanı sıra müşteri memnuniyeti önceliğimizdir.

Tüm çalışma ekibimiz her müşteriye ayrı, bireysel uzman bilgisi ile öneri ve destekte bulunmaktadır. Her şekilde hızlı ve tatmin edici çözümler sunmaktayız.

Hedefimiz geniş uzman bilgisi, esneklik ve rekabet fiyatları ile yüksek kalite sayesinde farklı olabilmemiz.

Önerilere, kendimizi sürekli geliştirmek anlamında açığız. Tüm ekibimizi soru ve cevaplarınız için sizlere her zaman yardımcı olacaktır, sizin memnuniyetiniz bizim başarımızdır.

🇬🇧 HOFMANN: YOUR PARTNER IN FOOD SERVICE AND CATERING EQUIPMENT

Many years of experience and reliability in trading professional gastronomy equipment have allowed us to establish as a mid-size company in the global market.

Our support with precision, flexibility and comprehensive services have been highly appreciated by our customers from all over Germany and Middle Europe.

We are proud of presenting our wide product range, which includes the Eco – Series and the Professional Series. This option allows our partners a huge offer of gastronomy equipment.

Our products can be used depending on their request in pizzerias, restaurants, public houses, canteens, business caterings.

In addition to the quick service, the customer satisfaction is our highest priority.

The whole team takes care of each customer and supports them, with their independent, professional advices, to optimally meet their requests. Kindly notice, that we provide quick and satisfy solutions.

Our aim is to distinguish us through a wide professional knowledge, strong flexibility, current competitive prices, quick delivery and high quality.

We are pleased to accept improvement proposals as a continuous extension of our business.

Our team is always willingly to help and support in any question or answer due to the fact your satisfaction is our success.

🇳🇱 HOFMANN: UW PARTNER IN HORECA- EN CATERING APPARATUUR

Dankzij jarenlange ervaring met professionele horeca apparatuur hebben we onze naam gevestigd als betrouwbaar middelgroot bedrijf op de wereldwijde markt.

Onze ondersteuning met oog voor detail en flexibiliteit zijn zeer gewaardeerd door klanten uit heel Duitsland en midden Europa. Wij presenteren met trots ons uitgebreide assortiment, met onder andere een eco serie en een professionele serie. Door ons brede assortiment bieden wij onze partners een ruime keuze in horeca apparatuur. Onze producten kunnen afhankelijk van uw wensen gebruikt worden in pizzeria's, restaurants, cafés, kantines tot bedrijfskantines.

Naast een snelle service is de tevredenheid van de klant onze hoogste prioriteit.







Het hele team draagt zorg voor elke klant en ondersteunt hen met onafhankelijke, professionele adviezen om een passende oplossing te bieden op elk verzoek.











Ons doel is om ons te onderscheiden door brede vakkennis, flexibiliteit, concurrerende prijzen, snelle levering en een hoge kwaliteit.











We staan altijd open voor suggesties om ons bedrijf te verbeteren en uit te breiden.

Mocht u vragen hebben dan staat ons team altijd voor u klaar om u te helpen. Uw tevredenheid is ons succes.

				
	Externe afmetingen lxdxh	External dimensions lxdxh	Dimentions extérieures lxdxh	Abmessungen extern lxdxh
	Interne afmetingen lxdxh	Internal dimensions lxdxh	Dimentions intérieures lxdxh	Abmessungen intern lxdxh
	Dikte	Thickness	Épaisseur	Materialstärke
	Doorsnede	Diameter	Diamètre	Durchmesser
	Gas	Gas	Gaz	Gas
	Volt/kW	Volt/kW	Volt/kW	Volt/kW
	Gewicht	Weight	Poids	Gewicht
	Voorraad	Stock	Stock	Lagerbestand
	Prijs	Price	Prix	Preis
	Graden Celcius	Degrees Celsius	Degrés Celcius	Grad Celcius
	Opgewarmd in sec.	Heated within sec.	Chauffant en sec.	Temperiert in sek.
	GN Maat	GN Size	GN taille	GN Größe
	Roosters	Grids	Grille	Einlegeroste
EN	Euronorm (EN)	Euronorm (EN)	Euronorm (EN)	Euronorm (EN)
	Glad	Smooth	Lisse	glatt
	Geribbled	Grooved	Rainurées	gerillt
	Chroom	Chrome	Chrome	verchromt
	Grill oppervlakte	Grill surface	Surface Grill	Grillfläche
	Afmetingen plaat boven	Dimensions plate above	Dimensions plaque de dessus	Abmessungen Bratfläche oben
	Afmetingen plaat onder	Dimensions plate under	Dimensions plaque de dessous	Abmessungen Bratfläche unten
	Statisch	Static	Statique	Statisch
	Geventileerd	Ventilated	Ventilé	Umluft
	Automatische ontdooiing	Automatic defrost	Dégivrage automatique	automatische Abtaufunktion
	Handmatige ontdooiing	Manual defrost	Dégivrage manuel	manuelle Abtaufunktion
	Deur slot	Door lock	Serrure	Türschloss
	Draairichting deur instelbaar	Adjustable door rotation	Porte interchangeable	Türanschlag wechselbar
	Inhoud liter	Content litres	Contenu en litres	Inhalt in Liter
	Kg per uur	Kg per hour	Kg par heure	Kg per Stunde
	Capaciteit KG/24	Capacity KG/24	Capacité KG/24	Traglast 24 kg
	Opslag cap KG	Storage KG	Stockage en KG	Belastbarkeit in kg
	Capaciteit Gram	Capacity gram	Capacité en gram	Belastbarkeit in g
	Capaciteit M3	Capacity M3	Capacité M3	Volumen m ³

				
	Aantal flessengaten	Number of bottle holes	Nombre de trous a bouteille	Anzahl Flaschenaufnahmen
	Aantal flessen	Number of bottles	Nombre de Bouteilles	Anzahl Flaschen
	Aantal blikjes	Number of cans	Nombre de Canettes	Anzahl Dosen
R	Koudemiddel	Refrigerant	Gaz réfrigérant	Kältemittel
	Doorsnede pizza's	Diameter pizza	Diamètre pizza	Durchmesser Pizzen
	Aantal pizza's	Number of pizza's	Nombre de pizzas	Anzahl Pizzen
	Doorsnede snijblad	Diameter blade	Diamètre de la lame	Klinge Durchmesser
	Snijdikte	Slice thickness	Épaisseur de la tranche	Schnittstärke
	Cyclusduur	Duration cycle	Durée du cycle	Dauer Zyklus
	Korven per uur	Racks per hour	Paniers par heure	Körbe per Stunde
	Snelheden	Speeds	Vitesses	Drehzahl
	Korven glas	Basket glass	Panier a verres	Gläserkorb
	Korven bestek	Basket cutlery	Panier a couverts	Besteckkorb
	Korven borden	Basket dishes	Panier a assiettes	Tellerkorb
	Laadhoogte	Loading height	Hauteur de chargement	Einschubhöhe
	Drainage	Drainage	Drainage	Ablauf
	Kraan aansluiting	Faucet connection	Connection robiner	Wasserzulauf
	Kraan montagegat	Faucet mounting hole	Trou a montage robinet	Wasseranschluß
	Ampere	Ampere	Ampère	Ampere
Rpm	Rpm	Rpm	Nombre de Tours/Min	U/min
	Tafel (aantal poten)	Table (nr. of legs)	Table (no. du pieds)	Tisch (anzahl Tischbeinen)
	Wasbak	Sink	Lavabo	Waschbecken
	Etaleerdiepte vitrines	Display surface depth	Profondeur etageré vitrine	Auflagentiefe Vitrine
	Onderkoeling vitrines	Under Storage	Dessous Réfrigeré	Gekühlter Vitrinenunterbau
	Afmetingen deur	Dimensions Door	Dimensions de la porte	Türabmessungen
	Isolatie mm	Insulation mm	Isolation en mm	Isolationsstärke in mm
	Standenregelaar	Speed controller	Régulateur de vitesse	Geschwindigkeitsregle
	Verlichting	Lighting	Éclairage	Beleuchtung
	Motor	Fan	Ventilateur	Ventilator
	Afmetingen Uitblaas	Exhaust dimensions	Dimensions sortie du flux	Abmessungen Abluft
	Cilinder	Cylinders	Cylindres	Zylinder
	Druk en zetfouten voorbehouden	Subject to typesetting and printing errors	Sous réserve d'erreur d'impression et de composition	Satz- und druckfehler vorbehalten

				
	Wielenset	Castors set	Série de roues	Rädersatz
	Geleiderset	Set Guides	Série de conducteur	Set Einschubleisten
	rooster	Grids	Grille	Einlegerost
	Clip voor rooster	Clip for grid	Clip de grille	Halteclips für Einlegeroste
	Ladenset	Drawerset	Bloc de tiroirs	Schubladensatz
	Set kratten	Set baskets	Chaise au-Dessus	Kastenschubladensatz
	Mand vrieskist	Basket freezer	Panier Congélateur Bahut	Körbe Tiefkühltruhe

	Cooking range	8	Cooking range
	Drop-in	48	Drop-in
	Ovens	58	Ovens
	Kitchen equipment	72	Kitchen equipment
	Refrigeration	100	Refrigeration
	Dishwashers	160	Dishwashers
	Neutral	170	Neutral
	Faucets	208	Faucets
	Ventilation	214	Ventilation
	Pizzeria	238	Pizzeria
	Bakery	256	Bakery

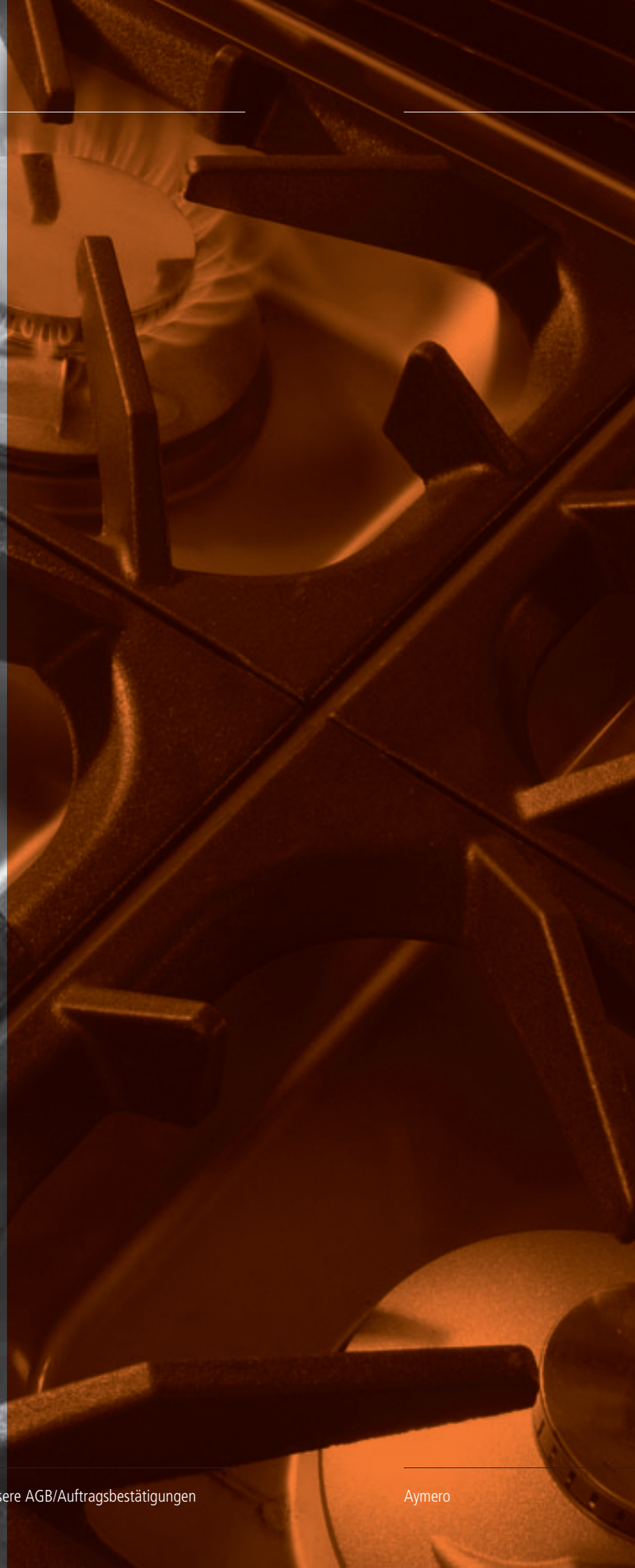
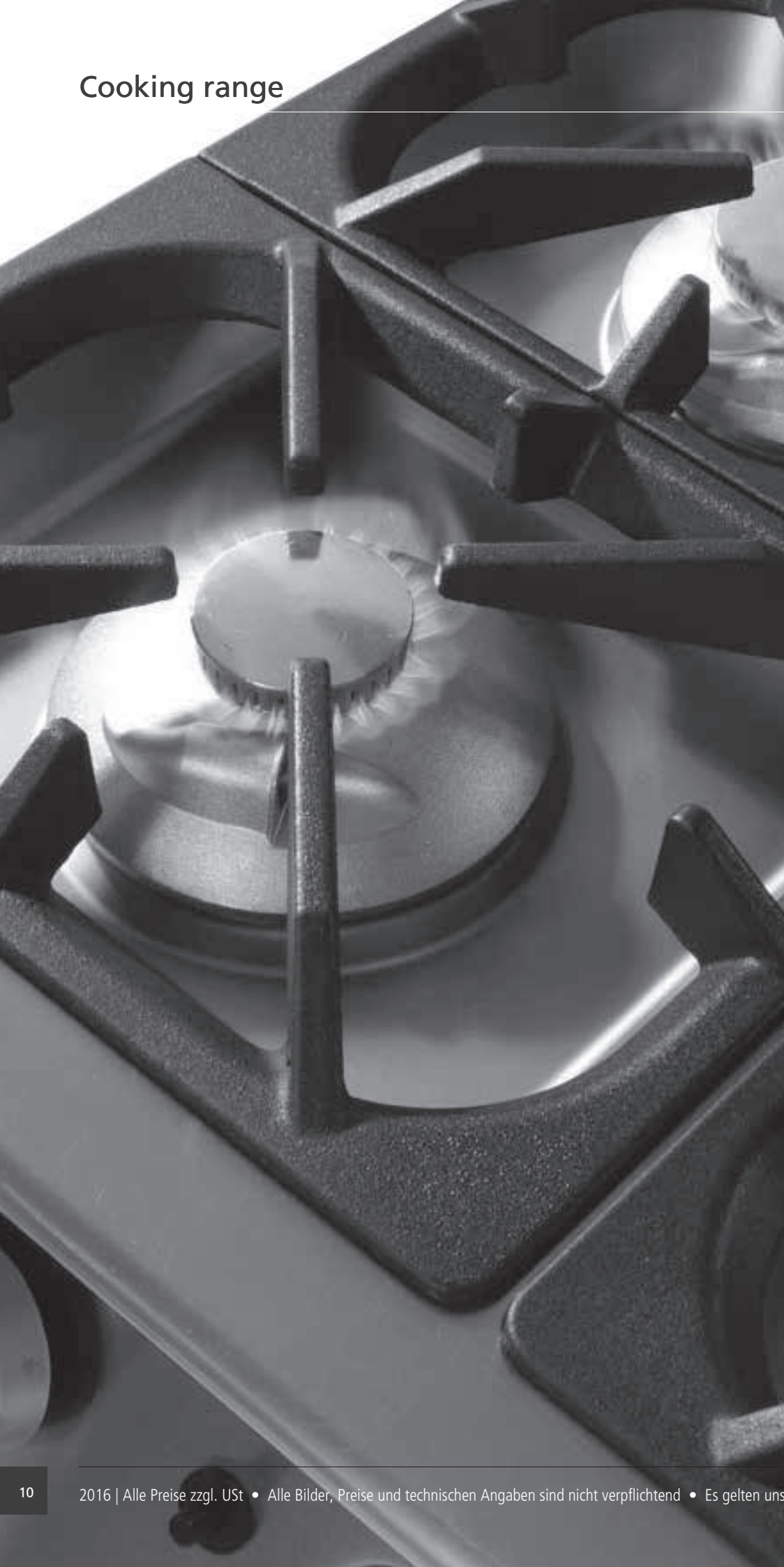

Kooklijnen
Kochstelle
Cooking range
Ligne de cuisson



Cooking range

Drop-in

Ovens

Kitchen equipment

Refrigeration

Dishwashers

Neutral

Faucets

Ventilation

Pizzeria

Bakery





GAS RANGE

-  GASKOOKUNIT
-  GASHERD
-  GAS RANGE
-  CUISINIERE A GAZ









	7478.0100
	400x600x265
	2x 3,6 kW
	15
	€ 429,- 





ELECTRIC RANGE

-  KOOKUNIT ELECTRISCH
-  ELEKTROHERD
-  ELECTRIC RANGE
-  CUISINIERE ÉLECTRIQUE



	7478.0115
	400x600x265
	400V /2x2 kW
	2x 180
	15
	€ 461,- 



FRY TOP CHROME

-  BAKPLAAT CHROOM
-  GRILL PLATTE CHROM
-  FRY TOP CHROME
-  PLAQUES GRILL CHROME



	7478.0140
	400x600x265
	400V /4,1 kW
	32
	€ 789,- 

	7478.0105
	600x600x265
	4x 3,6 kW
	19
	€ 751,- 

	7478.0120
	600x600x265
	400V 3X2 1X1 kW
	4x 180
	22
	€ 815,- 

	7478.0145
	600x600x265
	4,8 kW
	62
	€ 1.092,- 

GRID FOR PAN





-  VERKLEINROOSTER
-  ROST FÜR PFANNE
-  GRID FOR PAN
-  GRILLE POUR FAITOUT

	7488.9055
	€ 5,- 







	7478.0147
	400x600x265
	4,1 kW
	37
	€ 659,- 

ELECTRIC PASTA COOKER

-  PASTAKOKER ELECTRISCH
-  ELEKTRO NUDELKOCHER
-  ELECTRIC PASTA COOKER
-  CUISEURS POUR PÂTES ÉLECTRIQUE







	7478.0155
	400x600x265
	230V /3,6 kW
	14
	15
	€ 725,- 

BASKET PASTA COOKER

-  MAND PASTAKOKER
-  KORB NUDELKOCHER
-  BASKET PASTA COOKER
-  PANIER CUISEURS PÂTE

	7478.0150
	145x200x170
	€ 75,- 

ELECTRIC BAIN MARIE





-  BAIN MARIE ELECTRISCH
-  ELEKTRO BAIN MARIE
-  ELECTRIC BAIN MARIE
-  BAIN MARIE À ÉLECTRIQUE









	7478.0125
	400x600x265
	230 V / 0,8 kW
	3/4
	13
	11
	€ 555,- 









ELECTRIC FRYER





-  FRITEUSE ELECTRISCH
-  ELEKTRO FRITEUSEN
-  ELECTRIC FRYER
-  FRITEUSE A ÉLECTRIQUE



	7478.0130
	400x600x265
	400V / 7,5 kW
	1 x 8
	17
	€ 836,- 

	7478.0135
	600x600x265
	400V / 2x 7,5 kW
	2 x 8
	28
	€ 1.565,- 





GAS LAVA STONE GRILL

-  LAVASTEENGRIL GAS
-  GASLAVASTEINGRILL
-  GAS LAVA STONE GRILL
-  GRILL PIERRE LAVIQUE GAZ



	7478.0110
	600x600x265
	✓
	2x 4,8 kW
	43
	€ 1.073,- 

SUPPORT WITH DOOR

-  ONDERSTEL MET DEUR
-  UNTERBAU MIT TÜR
-  SUPPORT WITH DOOR
-  SOUBASSEMENT AVEC PORTE



	7478.0185
	400x520x660
	15
	€ 246,- 

	7478.0190
	600x520x660
	19
	€ 305,- 

JOINT





-  KOPPELSTUK
-  VERBINDUNG
-  JOINT
-  CONNEXION

	7478.0195
	€ 16,- 

NEUTRAL UNIT

-  NEUTRAAL ELEMENT
-  NEUTRAL ELEMENT
-  NEUTRAL UNIT
-  UNITÉ NEUTRE







	7478.0160
	400x600x265
	18
	€ 229,- 

SUPPORT

-  ONDERSTEL
-  UNTERBAU
-  SUPPORT
-  SOUBASSEMENT



	L	D	H		€
7478.0165	800	600	635	11	352,- 
7478.0170	1200	600	635	16	395,- 
7478.0175	1600	600	635	21	435,- 
7478.0180	2000	600	635	26	476,- 





GAS RANGE

-  GASKOOKTAFEL
-  GASHERD
-  GAS RANGE
-  CUISINIERE A GAZ



	7478.0500
	400x700x900
	2x 6 kW
	44
	€ 960,- 





GAS RANGE WITH GAS OVEN

-  GASFORNUIS MET GASOVEN
-  GASHERD MIT GASBACKOFEN
-  GAS RANGE WITH GAS OVEN
-  CUISINIERE A GAZ AVEC FOUR A GAZ



	7478.0507
	800x700x900
	4x 6 kW
	110
	€ 2.178,- 

ELECTRIC RANGE

-  KOOKTAFEL ELECTRISCH
-  ELEKTROHERD
-  ELECTRIC RANGE
-  CUISINIERE ÉLECTRIQUE



	7478.0535
	400x700x900
	400V / 2x2,6 kW
	2x 220
	37
	€ 725,- 

	7478.0505
	800x700x900
	4x 6 kW
	79
	€ 1.420,- 

	7478.0512
	1200x700x900
	6x 6 kW
	140
	€ 2.660,- 

	7478.0540
	800x700x900
	400V / 4x2,6 kW
	4x 220
	44
	€ 1.095,- 





	7478.0510
	1200x700x900
	6x 6 kW
	102
	€ 1.870,- 

GRID FOR PAN

-  VERKLEINROOSTER
-  ROST FÜR PFANNE
-  GRID FOR PAN
-  GRILLE POUR FAITOUT

	7488.9055
	€ 5,- 





GAS FRY TOP CHROME

-  GASBAKPLAAT CHROOM
-  GAS GRILLPLATTE CHROM
-  GAS FRY TOP CHROME
-  PLAQUES GRILL A GAZ CHROME



	7478.0515
	400x700x900
	✓
	6 kW
	61
	€ 1.129,- 





ELECTRIC FRY TOP CHROME

-  BAKPLAAT ELECTRISCH CHROOM
-  ELEKTRO GRILLPLATTE CHROM
-  ELECTRIC FRY TOP CHROME
-  PLAQUES GRILL A ÉLECTRIQUE CHROME



	7478.0545
	400x700x900
	✓
	400V / 4,05 kW
	62
	€ 1.110,- 

GAS LAVA STONE GRILL





-  LAVASTEENGRIL GAS
-  GAS LAVASTEINGRILL
-  GAS LAVA STONE GRILL
-  GRILL PIERRE LAVIQUE GAZ



	7478.0520
	400x700x900
	✓
	7 kW
	78
	€ 1.255,- 





	7478.0550
	800x700x900
	✓
	400V / 8,1 kW
	106
	€ 1.699,- 

GAS FRYER

-  GASFRITEUSE
-  FRITEUSE GAS
-  GAS FRYER
-  FRITEUSE À GAZ







ELECTRISCH FRYER

-  FRITEUSE ELECTRISCH
-  ELEKTRO FRITEUSEN
-  ELECTRISCH FRYER
-  FRITEUSE À ÉLECTRIQUE







ELECTRIC BAIN MARIE







-  BAIN MARIE ELECTRISCH
-  ELEKTRO BAIN MARIE
-  ELECTRIC BAIN MARIE
-  BAIN MARIE À ÉLECTRIQUE

















ELECTRIC PASTA COOKER







-  PASTAKOKER ELECTRISCH
-  ELEKTRO NUDELKOCHER
-  ELECTRIC PASTA COOKER
-  CUISEURS POUR PÂTES ÉLECTRIQUE











	7478.0525
	400x700x900
	1 x 10kW
	1 x 10
	43
	€ 1.529,- 

	7478.0560
	400x700x900
	400V/ 9 kW
	1 x 10
	43
	€ 1.382,- 

	7478.0555
	400x700x900
	230V / 1kW
	GN 1/1
	21
	36
	€ 912,- 



	7478.0570
	400x700x900
	400V / 4,5kW
	14
	39
	€ 1.325,- 

	7478.0530
	800x700x900
	2 x 10kW
	2 x 10
	73
	€ 2.645,- 

	7478.0565
	800x700x900
	400V/ 2 x 9 kW
	2 x 10
	73
	€ 2.228,- 

BASKET PASTA COOKER

-  MAND PASTAKOKER
-  KORB NUDELKOCHER
-  BASKET PASTA COOKER
-  PANIER CUISEURS PÂTE





	7478.0150
	145x200x170
	€ 75,- 

NEUTRAL UNIT

-  NEUTRAAL ELEMENT
-  NEUTRALELEMENT
-  NEUTRAL UNIT
-  UNITÉ NEUTRE







DOOR FOR NEUTRAL UNIT

-  DEUR VOOR NEUTRAAL ELEMENT
-  TÜR FÜR NEUTRALELEMENT
-  DOOR FOR NEUTRAL UNIT
-  PORTE POUR







	7478.0575
	400x700x900
	34
	€ 407,- 

	7478.0585
>	7478.0575
	4
	€ 54,- 

	7478.0580
	800x700x900
	55
	€ 530,- 



	7478.0590
>	7478.0580
	8
	€ 108,- 

JOINT

-  KOPPELSTUK
-  VERBINDUNG
-  JOINT
-  CONNEXION







7478.0605
€ 22,- 



GAS RANGE

-  GASKOOKUNIT
-  GASHERD
-  GAS RANGE
-  CUISINIÈRE A GAZ









	7488.0005
	400x700x250
	2x 5,5 kW
	27
	€ 1.249,- 





GRID FOR PAN

-  VERKLEINROOSTER
-  ROST FÜR PFANNE
-  GRID FOR PAN
-  GRILLE POUR FAITOUT







	7488.9055
	€ 5,- 

	7488.0010
	800x700x250
	4x 5,5 kW
	45
	€ 1.595,- 





RADIANT PLATE FOR 1 BURNER

-  KOOKPLAAT VOOR 1 BRANDER
-  KOCHPLATTE FÜR 1 BRENNER
-  RADIANT PLATE FOR 1 BURNER
-  PLAQUE POUR 1 BRULEUR

	7488.9060
	300x340x50
	4
	€ 110,- 

	7488.0015
	1200x700x250
	33 kW / 6x 5,5 kW
	63
	€ 2.687,- 

GAS RANGE WITH OVEN

-  GASFORNUIS MET OVEN
-  GASHERD MIT BACKOFEN
-  GAS RANGE WITH OVEN
-  CUISINIÈRE A GAZ AVEC FOUR



	7488.0020
	800x700x850
	4x 5,5 kW
	6 kW
	110 / 270
	103
	€ 2.933,- 





GRID FOR PAN

-  VERKLEINROOSTER
-  ROST FÜR PFANNE
-  GRID FOR PAN
-  GRILLE POUR FAITOUT









	7488.9055
	€ 5,- 

	7488.0025
	800x700x850
	4x 5,5 kW
	400 V / 6 kW
	140 / 300
	104
	€ 3.580,- 

RADIANT PLATE FOR 1 BURNER





-  KOOKPLAAT VOOR 1 BRANDER
-  KOCHPLATTE FÜR 1 BRENNER
-  RADIANT PLATE FOR 1 BURNER
-  PLAQUE POUR 1 BRULEUR

	7488.9060
	300x340x50
	4
	€ 110,- 





	7488.0030
	1200x700x850
	6x 5,5 kW
	6 kW
	110 / 270
	130
	€ 3.825,- 

GRID 2/1 GN

-  ROOSTER 2/1 GN
-  ROST 2/1 GN
-  GRID 2/1 GN
-  GRILLE 2/1 GN

	7488.9065
	650x530x10
	1
	€ 28,- 





SOLID TOP GAS

-  KOOKPLAATUNIT GAS
-  GLÜHPLATTE GAS
-  SOLID TOP GAS
-  CUISINIÈRE A PLAQUE COUP DE FEU A GAZ



	7488.0040
	800x700x250
	7 kW
	73
	€ 2.552,-

SOLID TOP RANGE GAS OVEN

-  KOOKPLAATFORNUIS GAS OFEN
-  GLÜHPLATTENHERD GAS OFEN
-  SOLID TOP RANGE GAS OVEN
-  CUISINIÈRE PLAQUES COUP DE FEU AVEC FOUR GAZ



	7488.0055
	800x700x850
	13 kW
	6 KW
	110 / 270
	116
	€ 3.699,-

	7488.0065
	1200x700x850
	24 kW 2x 5,5 / 1x 7
	6 KW
	110 / 270
	160
	€ 4.838,-

	7488.0045
	800x700x250
	14,8 kW 2x 5,5 / 1x 3,8
	70
	€ 2.241,-





	7488.0060
	800x700x850
	20,6 kW 2x 5,5 / 1x 3,8
	6 KW
	110 / 270
	115
	€ 3.769,-

GRID FOR PAN

-  VERKLEINROOSTER
-  ROST FÜR PFANNE
-  GRID FOR PAN
-  GRILLE POUR FAITOUT

	7488.9055
	€ 5,-

RADIANT PLATE FOR 1 BURNER

-  KOOKPLAAT VOOR 1 BRANDER
-  KOCHPLATTE FÜR 1 BRENNER
-  RADIANT PLATE FOR 1 BURNER
-  PLAQUE POUR 1 BRULEUR

	7488.9060
	300x340x50
	4
	€ 110,-

GRID 2/1 GN

-  ROOSTER 2/1 GN
-  ROST 2/1 GN
-  GRID 2/1 GN
-  GRILLE 2/1 GN

	7488.9065
	650x530x10
	1
	€ 28,-

ELECTRIC RANGE

-  ELEKTRISCHE KOOKUNIT
-  ELEKTROHERD
-  ELECTRIC RANGE
-  CUISINIÈRE ELECTRIQUE







	7488.0070
	400x750x250
	400 V / 2x 2,6 kW
	2x Ø230
	20
	€ 921,-

	7488.0075
	800x700x250
	400 V / 4x 2,6 kW
	4x Ø230
	40
	€ 1.356,-

	7488.0080
	800x700x250
	400 V / 4x 2,6 kW
	4x 230x230
	40
	€ 3.110,-

	7488.0085
	1200x700x250
	400 V / 6x 2,6 kW
	6x Ø230
	70
	€ 2668,-

ELECTRIC STOVE WITH EL. OVEN





-  ELEKTRISCH FORNUIS MET ELEKTRISCHE OFEN
-  ELEKTROHERD MIT ELEKTRO BACKOFEN
-  ELECTRIC STOVE WITH ELECTRIC OVEN
-  CUISINIÈRE ÉLECTRIQUE AVEC FOUR ÉL.





	7488.0090
	800x700x850
	400 V / 4x 2,6 kW
	6 kW
	4x 230x230
	140 / 300
	80
	€ 5.273,-





	7488.0095
	800x700x850
	400 V / 4x 2,6 kW
	6 kW
	4x Ø230
	140 / 300
	80
	€ 3.202,-

GRID 2/1 GN

-  ROOSTER 2/1 GN
-  ROST 2/1 GN
-  GRID 2/1 GN
-  GRILLE 2/1 GN

	7488.9065
	650x530x10
	1
	€ 28,-

INDUCTION RANGE

-  INDUCTIE KOOKUNIT
-  INDUKTION HERD
-  INDUCTION RANGE
-  INDUCTION CUISINIÈRE















	7488.0100
	400x700x250
	400 V / 2x 3,5 kW
	20
	€ 6.253,-

	7488.0105
	800x700x250
	400 V / 4x 3,5 kW
	40
	€ 11.389,-





GAS FRY TOP

-  GAS BAKPLAAT
-  GAS GRILL PLATTE
-  GAS FRY TOP
-  PLAQUES GRILL A GAZ

















	7488.0110	7488.0115	7488.0120
			
	400x700x250	400x700x250	400x700x250
	7 kW	7 kW	7 kW
	200 / 400	200 / 400	130 / 300
	330x540	330x540	330x540
	40	40	40
€	1.517,- 	1.831,- 	3.995,- 

ELECTRIC FRY TOP

-  ELEKTRISCHE BAKPLAAT
-  ELEKTRO GRILL PLATTE
-  ELECTRIC FRY TOP
-  PLAQUES GRILL A ELECTRIQUE

















	7488.0125	7488.0130	7488.0135	7488.0140
				
	400x700x250	400x700x250	400x700x250	400x700x250
	400 V / 4,2 kW	400 V / 4,2 kW	400 V / 4,2 kW	400 V / 4,2 kW
	110 / 280	110 / 300	110 / 300	110 / 280
	330x540	330x540	330x540	330x540
	47	47	47	47
€	1.742,- 	1.457,- 	1.796,- 	1.901,- 





GAS FRY TOP

-  GAS BAKPLAAT
-  GAS GRILL PLATTE
-  GAS FRY TOP
-  PLAQUES GRILL A GAZ

















	7488.0145	7488.0150	7488.0155	7488.0160
				
	800x700x250	800x700x250	800x700x250	800x700x250
	14kW	14kW	14kW	14kW
	200 / 400	200 / 400	130 / 300	130 / 300
	730x540	730x540	730x540	730x540
	84	84	84	84
€	2.177,- 	2.633,- 	2.979,- 	3.683,- 



ELECTRIC FRY TOP

-  ELEKTRISCHE BAKPLAAT
-  ELEKTRO GRILL PLATTE
-  ELECTRIC FRY TOP
-  PLAQUES GRILL A ELECTRIQUE



	7488.0165	7488.0170	7488.0175	7488.0180
				
	800x700x250	800x700x250	800x700x250	800x700x250
	400 V / 8,4 kW	400 V / 8,4 kW	400 V / 8,4 kW	400 V / 8,4 kW
	110 / 300	110 / 300	110 / 280	110 / 280
	730x540	730x540	730x540	730x540
	84	84	84	84
€	2.066,- 	2.441,- 	3.995,- 	3.256,- 

ACCESSORIES









	7488.9045		
>		€ 36,- 	

	7488.9050		
>		€ 34,- 	

ELECTRIC FRYER

-  ELEKTRISCHE FRITEUSE
-  ELEKTRO FRITEUSEN
-  ELECTRIC FRYER
-  FRITEUSE A ELECTRIQUE











	7488.0210	7488.0215
	400x700x850	800x700x850
	400 V / 8,7 kW	400 V / 17,4 kW
	105 / 185	105 / 185
	1x 14	2x 14
	✓	✓
	40	50
€	2.085,- 	3.452,- 

ELECTRIC FRYER

-  ELEKTRISCHE FRITEUSE
-  ELEKTRO FRITEUSEN
-  ELECTRIC FRYER
-  FRITEUSE A ELECTRIQUE











	7488.0185	7488.0190	7488.0195
	400x700x250	400x700x250	400x700x250
	400 V / 9 kW	400 V / 8,7 kW	400 V / 17,4 kW
	105 / 185	105 / 185	105 / 185
	2x 5	1x 12	2x 12
	✓	✓	✓
	13	32	24
€	3.083,- 	2.001,- 	3.275,- 







GAS FRYER

-  GASFRITEUSE
-  GAS FRITEUSEN
-  GAS FRYER
-  FRITEUSE A GAZ











	7488.0200	7488.0205
	400x700x850	800x700x850
	14 kW	28 kW
	105 / 185	105 / 185
	1x 15	2x 15
	✓	✓
	40	50
€	2.574,- 	4.583,- 

ACCESSORIES





	7488.9025		
>5L		€ 84,- 	
	7488.9030		
>12L		€ 42,- 	
	7488.9035		
>14/15L		€ 42,- 	

CHIPS SCUTTLE

-  FRIETWARMHOUDUNIT
-  POMMES FRITES WARMER
-  CHIPS SCUTTLE
-  CHAUFFE FRITES

	7488.0220		
	400x700x250		
	230 V / 1 kW		
GN	1/1		
	20		
€	1.445,- 		

GAS LAVA STONE GRILL







-  GAS LAVASTEENGRILL
-  GASLAVASTEINGRILL
-  GAS LAVA STONE GRILL
-  GRILL PIERRE LAVIQUE GAZ















ELECTRIC GRILL

-  ELEKTRISCHE GRILL
-  ELEKTRO GRILL
-  ELECTRIC GRILL
-  GRILL ELECTRIQUE







	7488.0225
	400x700x250
	7 kW
	39
	€ 1.789,- 

	7488.0235
	400x700x250
	400 V / 4 kW
	39
	€ 2.147,- 

	7488.0230
	800x700x250
	14 kW
	40
	€ 2.700,- 

	7488.0240
	800x700x250
	400 V / 12 kW
	40
	€ 3.146,- 

ELECTRIC BAIN-MARIE





-  ELEKTRISCHE BAIN-MARIE
-  ELEKTRO BAIN-MARIE
-  ELECTRIC BAIN-MARIE
-  BAIN-MARIE A ELECTRIQUE



	7488.0245
	400x700x250
	400 V / 3 kW
	30 / 90
	GN 1x 1/1
	✓
	20
	€ 1.120,- 

	7488.0250
	800x700x250
	230 V / 3 kW
	30 / 90
	GN 2x 1/1
	✓
	25
	€ 2.176,- 

GAS PASTA COOKER





-  GAS PASTAKOKER Excl. Manden
-  GAS NUDELKOCHER Exkl. Körbe
-  GAS PASTA COOKER Excl. Baskets
-  CUISEURS POUR PATES GAZ Excl. Paniers









	7488.0260
	400x700x850
	1x250x400x300
	10,5 kW
	40
	€ 2.759,- 

	7488.0265
	800x700x850
	2x250x400x300
	21 kW
	60
	€ 4.420,- 

ELECTRIC PASTA COOKER

-  ELEKTRISCHE PASTAKOKER Excl. Manden
-  ELEKTRO NUDELKOCHER Exkl. Körbe
-  ELECTRIC PASTA COOKER Excl. Baskets
-  CUISEURS POUR PATES A ELECTRIQUE Excl. Paniers







	7488.0270
	400x700x850
	1x250x400x300
	400 V / 6 kW
	40
	€ 2.973,- 

	7488.0275
	800x700x850
	2x250x400x300
	400 V / 12 kW
	50
	€ 5.030,- 

ACCESSORIES





	7488.9000	2x 220x170	€ 263,- 
	7488.9005	4x 105x160	€ 316,- 

ELECTRIC BOILING PAN

-  ELEKTRISCHE KOOKKETEL Indirecte verhitting
-  ELEKTRO KOCHKESSEL Indirekt beheizt
-  ELECTRIC BOILING PAN Indirect heating
-  MARMITES A ELECTRIQUE Chauffage indirect



GAS BOILING PAN





-  GAS KOOKKETEL Directe verhitting
-  GAS KOCHKESSEL Direkt beheizt
-  GAS BOILING PAN Direct heating
-  MARMITES À GAZ Chauffage direct







7488.0255	
	H 800x700x850
	400 V / 9,4 kW
	60
	✓
	115
€	5.594,- 

7488.0257	
	H 800x700x850
	14 kW
	60
	✓
	110
€	4.779,- 





GAS MULTI COOKING PAN

-  GAS VARIPAN
-  GAS MULTI-BRATER
-  GAS MULTI COOKING PAN
-  MULTI-SAUTEUSE A GAZ







7488.0280	
	H 400x700x850
	7 kW
	100 / 250
	55
€	4.417,- 



ELECTRIC MULTI COOKING PAN

-  ELEKTRISCHE VARIPAN
-  ELEKTRO MULTI-BRATER
-  ELECTRIC MULTI COOKING PAN
-  MULTI-SAUTEUSE ELECTRIQUE



7488.0290	
	H 400x700x850
	400 V / 5 kW
	100 / 250
	40
€	4.093,- 

7488.0285	
	H 800x700x850
	14 kW
	100 / 250
	95
€	6.094,- 

7488.0295	
	H 800x700x850
	400 V / 10 kW
	100 / 250
	80
€	5.727,- 



GAS TILTING PAN

-  GAS KANTELBARE BRAADSLEDE
Plaatstaal - Handmatige kanteling
-  GAS KIPBRATPFANNE
Stahlblech - Manuelles heben
-  GAS TILTING PAN
Sheet steel - Manual tilting
-  SAUTEUSE BASCULANTES A GAZ
Acier - Levage manual









7488.0300	
	800x700x850
	16 kW
	90 / 290
	60
	120
	5.495,- 





ELECTRIC TILTING PAN

-  EL. KANTELBARE BRAADSLEDE
Plaatstaal - Handmatige kanteling
-  ELEKTRO-KIPBRATPFANNE
Stahlblech - Manuelles heben
-  ELECTRIC TILTING PAN
Sheet steel - Manual tilting
-  SAUTEUSE BASCULANTES ELECTRIQUE
Acier - Levage manual







7488.0310	
	800x700x850
	400 V / 9,5 kW
	120 / 280
	60
	120
	5.478,- 

GAS TILTING PAN

-  GAS KANTELBARE BRAADSLEDE
RVS - Handmatige kanteling
-  GAS KIPBRATPFANNE
Edelstahl - Manuelles heben
-  GAS TILTING PAN
Stainless Steel - Manual tilting
-  SAUTEUSE BASCULANTES A GAZ
Inox - Levage manual

7488.0305	
	800x700x850
	16 kW
	90 / 290
	60
	120
	5.594,- 

ELECTRIC TILTING PAN

-  EL. KANTELBARE BRAADSLEDE
RVS - Handmatige kanteling
-  ELEKTRO-KIPBRATPFANNE
Edelstahl - Manuelles heben
-  ELECTRIC TILTING PAN
Stainless Steel - Manual tilting
-  SAUTEUSE BASCULANTES ELECTRIQUE
Inox - Levage manual

7488.0315	
	800x700x850
	400 V / 9,5 kW
	120 / 280
	60
	120
	5.665,- 

SUPPORT

-  ONDERSTEL
-  UNTERBAU
-  SUPPORT
-  SOUBASSEMENT







7488.0325	
	400x550x600
	15
	399,- 

7488.0330	
	800x550x600
	20
	470,- 

7488.0335	
	1200x550x600
	28
	477,- 

SUPPORT CLOSED

-  ONDERSTEL DICTH
-  UNTERBAU GESCHLOSSEN
-  SUPPORT CLOSED
-  SOUBASSEMENT FERMÉ



7488.0320	
	200x550x600
	20
	443,- 

NEUTRAL UNIT

-  NEUTRAAL ELEMENT
-  NEUTRAL ELEMENT
-  NEUTRAL UNIT
-  UNITÉ NEUTRAL



7488.0340	
	400x700x250
	20
	486,- 

7488.0345	
	800x700x250
	35
	675,- 

DOOR

-  DEUR
-  TÜR
-  DOOR
-  PORTE

7488.9020	
	PRO700 / 900
	5
	185,- 

GAS RANGE

-  GASKOOKUNIT
-  GASHERD
-  GAS RANGE
-  CUISINIÈRE À GAZ



GAS RANGE

-  GASKOOKUNIT
-  GASHERD
-  GAS RANGE
-  CUISINIÈRE À GAZ



GAS RANGE

-  GASKOOKUNIT
-  GASHERD
-  GAS RANGE
-  CUISINIÈRE À GAZ







	7488.0500
	400x900x250
	2x 6 kW
	43
	€ 1.563,- 

	7488.0510
	800x900x250
	1x 10+3x 6 kW
	79
	€ 2.500,- 

	7488.0520
	1200x900x250
	4x 6+2x 10 kW
	110
	€ 3.494,- 

	7488.0505
	400x900x250
	2 x 10 kW
	43
	€ 1.739,- 

	7488.0515
	800x900x250
	4x 10 kW
	79
	€ 2.703,- 





	7488.0525
	1200x900x250
	6x 10 kW
	135
	€ 3.785,- 

GRID FOR PAN

-  VERKLEINROOSTER
-  ROST FÜR PFANNE
-  GRID FOR PAN
-  GRILLE POUR FAITOUT





	7488.9055
	€ 5,- 

RADIANT PLATE FOR 1 BURNER

-  KOOKPLAAT VOOR 1 BRANDER
-  KOCHPLATTE FÜR 1 BRENNER
-  RADIANT PLATE FOR 1 BURNER
-  PLAQUE POUR 1 BRULEUR

	7488.9070
	300x340x50
	4
	€ 106,- 





GAS RANGE WITH OVEN

-  GASFORNUIS MET OVEN
-  GASHERD MIT BACKOFEN
-  GAS RANGE WITH OVEN
-  CUISINIÈRE A GAZ AVEC FOUR



	7488.0530
	800x900x850
	3x 6 / 1x 10 kW
	8,5 kW
	120 / 280
	142
	€ 4.477,- 





GAS RANGE WITH OVEN

-  GASFORNUIS MET OVEN
-  GASHERD MIT BACKOFEN
-  GAS RANGE WITH OVEN
-  CUISINIÈRE A GAZ AVEC FOUR



	7488.0540
	800x900x850
	3x 6 / 1x 10 kW
	400 V / 6 kW
	110 / 285
	180
	€ 4.741,- 

GAS RANGE WITH OVEN

-  GASFORNUIS MET OVEN
-  GASHERD MIT BACKOFEN
-  GAS RANGE WITH OVEN
-  CUISINIÈRE A GAZ AVEC FOUR



	7488.0545
	1200x900x850
	4x 6 / 2x 10 kW
	8,5 kW
	120 / 280
	203
	€ 5.889,- 

	7488.0535
	800x900x850
	4x 10 kW
	8,5 kW
	120 / 280
	155
	€ 4.674,- 





	7488.0550
	1600x900x850
	6x 6 / 2x 10 kW
	2x 8,5 kW
	120 / 280
	350
	€ 8.170,- 

GRID FOR PAN

-  VERKLEINROOSTER
-  ROST FÜR PFANNE
-  GRID FOR PAN
-  GRILLE POUR FAITOUT

	7488.9055
	€ 5,- 

RADIANT PLATE FOR 1 BURNER

-  KOOKPLAAT VOOR 1 BRANDER
-  KOCHPLATTE FÜR 1 BRENNER
-  RADIANT PLATE FOR 1 BURNER
-  PLAQUE POUR 1 BRULEUR





	7488.9070
	300x340x50
	4
	€ 106,- 

GRID 2/1 GN

-  ROOSTER 2/1 GN
-  ROST 2/1 GN
-  GRID 2/1 GN
-  GRILLE 2/1 GN

	7488.9065
	650x530x10
	1
	€ 28,- 





SOLID TOP GAS

-  KOOKPLAATUNIT GAS
-  GLÜHPLATTE GAS
-  SOLID TOP GAS
-  CUISINIÈRE A PLAQUES COUP DE FEU A GAZ



7488.0560	
	800x900x850
	10,5 kW
	115
€	2.468,- 





SOLID TOP RANGE GAS OVEN

-  KOOKPLAATFORNUIS GASOVEN
-  GLÜHPLATTENHERD GASBACKOFEN
-  SOLID TOP RANGE GAS OVEN
-  CUISINIÈRE PLAQUES COUP DE FEU AVEC FOUR A GAZ



7488.0565	
	800x900x850
	10,5 kW
	8,5 kW
	120 / 280
	140
€	4.452,- 





SOLID TOP RANGE GAS OVEN

-  KOOKPLAATFORNUIS GASOVEN
-  GLÜHPLATTENHERD GASBACKOFEN
-  SOLID TOP RANGE GAS OVEN
-  CUISINIÈRE PLAQUES COUP DE FEU AVEC FOUR A GAZ



7488.0570	
	1200x900x850
	1x 10 kW / 1x 6 kW / 1x10,5 kW
	8,5 kW
	120 / 280
	242
€	6.159,- 

SOLID TOP GAS

-  KOOKPLAATUNIT GAS
-  GLÜHPLATTE GAS
-  SOLID TOP GAS
-  CUISINIÈRE A PLAQUES COUP DE FEU A GAZ







7488.0575	
	400x900x250
	8 kW
	120 / 400
	63
€	2.238,- 





7488.0580	
	800x900x250
	16 kW
	120 / 400
	125
€	2.997,- 

INDUCTION RANGE

-  INDUCTIE KOOKUNIT
-  INDUKTION HERD
-  INDUCTION RANGE
-  INDUCTION CUISINIÈRE



7488.0600	
	400x900x250
	400 kW / 2x 5 kW
	60
€	6.674,- 

7488.0605	
	800x900x250
	400 kW / 4x 5 kW
	80
€	12.771,- 

GRID FOR PAN

-  VERKLEINROOSTER
-  ROST FÜR PFANNE
-  GRID FOR PAN
-  GRILLE POUR FAITOUT

7488.9055	
€	5,- 

RADIANT PLATE FOR 1 BURNER

-  KOOKPLAAT VOOR 1 BRANDER
-  KOCHPLATTE FÜR 1 BRENNER
-  RADIANT PLATE FOR 1 BURNER
-  PLAQUE POUR 1 BRULEUR

7488.9070	
	300x340x50
	4
€	106,- 

GRID 2/1 GN

-  ROOSTER 2/1 GN
-  ROST 2/1 GN
-  GRID 2/1 GN
-  GRILLE 2/1 GN

7488.9065	
	650x530x10
	1
€	28,- 

Cooking range

Drop-in

Ovens

Kitchen equipment

Refrigeration

Dishwashers

Neutral





Faucets

Ventilation







Pizzeria





Bakery

ELECTRIC RANGE





-  KOOKUNIT ELEKTRISCH
-  ELEKTROHERD
-  ELECTRIC RANGE
-  CUISINIÈRE ELECTRIQUE



	7488.0585
	400x900x250
	400 V / 2x 4 kW
	41
	€ 2.192,- 

	7488.0590
	800x900x250
	400 V / 4x 4 kW
	73
	€ 3.515,- 

ELECTRIC STOVE WITH ELECTRIC OVEN





-  ELEKTRISCH FORNUIS MET ELEKTRISCHE OVEN
-  ELEKTROHERD MIT ELEKTRO BACKOFEN
-  ELECTRIC STOVE WITH ELECTRIC OVEN
-  CUISINIÈRE ÉLECTRIQUE AVEC FOUR ÉLECTRIQUE



	7488.0595
	800x900x850
	400 kW / 4x 4 kW
	6 kW
	110 / 285
	145
	€ 5.829,- 

GRID 2/1 GN









-  ROOSTER 2/1 GN
-  ROST 2/1 GN
-  GRID 2/1 GN
-  GRILLE 2/1 GN

	7488.9065
	650x530x10
	1
	€ 28,- 

GAS FRYER

-  GASFRITEUSE
-  GAS FRITEUSE
-  GAS FRYER
-  FRITEUSE A GAZ













	L	D	H						€
7488.0695	400	900	850	14 kW	120 / 190 °C	1x 15	✓	63	3.834,- 
7488.0700	800	900	850	28 kW	120 / 190 °C	2x 15	✓	101	6.356,- 
7488.0705	400	900	850	20 kW	120 / 190 °C	2x 23	✓	75	3.842,- 
7488.0710	800	900	850	40 kW	120 / 190 °C	1x 23	✓	126	6.693,- 

ELECTRIC FRYER







-  ELEKTRISCHE FRITEUSE
-  ELEKTRO FRITEUSEN
-  ELECTRIC FRYER
-  FRITEUSE A ELECTRIQUE







	L	D	H						€
7488.0720	400	900	850	400 V / 10 kW	105 / 185 °C	1x 15	✓	60	3.858,- 
7488.0725	800	900	850	400 V / 20 kW	105 / 185 °C	2x 15	✓	98	6.159,- 
7488.0730	400	900	850	400 V / 16,5 kW	105 / 185 °C	1x 18	✓	60	3.256,- 
7488.0735	800	900	850	400 V / 33 kW	105 / 185 °C	2x 18	✓	115	5.846,- 
7488.0740	400	900	850	400 V / 18 kW	105 / 185 °C	1x 23	✓	67	3.872,- 
7488.0745	800	900	850	400 V / 36 kW	105 / 185 °C	2x 23	✓	116	7.682,- 

CHIPS SCUTTLE





-  FRIETWARMHOUDUNIT
-  POMMES FRITES WÄRMER
-  CHIPS SCUTTLE
-  CHAUFFE FRITES

	7488.0750
	400x900x250
	230 V / 1 kW
	30
	€ 1.652,- 
	GN 1/1

ACCESSORIES

	7488.9035	> 14 / 15 L	€ 42,- 
	7488.9040	> 18 / 23 L	€ 90,- 





GAS FRY TOP

-  GAS BAKPLAAT
-  GAS GRILL
-  GAS FRY TOP
-  PLAQUES GRILL A GAZ



	7488.0610	7488.0615	7488.0620
	400x900x250	400x900x250	400x900x250
	10 kW	10 kW	10 kW
	90 / 280	90 / 280	90 / 280
	330x700	330x700	330x700
	57	40	65
	€ 2.333,-	€ 2.417,-	€ 2.759,-

GAS FRY TOP

-  GAS BAKPLAAT
-  GAS GRILL
-  GAS FRY TOP
-  PLAQUES GRILL A GAZ



	7488.0640	7488.0645	7488.0650	7488.0655
	800x900x250	800x900x250	800x900x250	800x900x250
	20 kW	20 kW	20 kW	20 kW
	90 / 280	90 / 280	90 / 280	90 / 280
	730x700	730x700	730x700	730x700
	105	104	105	105
	€ 3.121,-	€ 3.564,-	€ 4.174,-	€ 4.328,-

ELECTRIC FRY TOP

-  EL. BAKPLAAT
-  ELKTRO GRILL PLATTE
-  ELECTRIC FRY TOP
-  PLAQUES GRILL A ELECTRIQUE



	7488.0625	7488.0630	7488.0635
	400x900x250	400x900x250	400x900x250
	400 V / 7,5 kW	400 V / 7,5 kW	400 V / 7,5 kW
	120 / 280	120 / 280	120 / 280
	330x700	330x700	330x700
	65	65	65
	€ 2.136,-	€ 2.368,-	€ 2.695,-





ELECTRIC FRY TOP

-  EL. BAKPLAAT
-  ELKTRO GRILL PLATTE
-  ELECTRIC FRY TOP
-  PLAQUES GRILL A ELECTRIQUE



	7488.0660	7488.0665	7488.0670	7488.0675
	800x900x250	800x900x250	800x900x250	800x900x250
	400 V / 15 kW	400 V / 15 kW	400 V / 15 kW	400 V / 15 kW
	120 / 280	120 / 280	120 / 280	120 / 280
	730x700	730x700	730x700	730x700
	105	100	120	120
	€ 2.997,-	€ 3.410,-	€ 2.012,-	€ 4.091,-

SOLID TOP RANGE GAS OVEN

-  GAS BAKPLAAT MET GASOVEN
-  GAS GRILL PLATTE MIT GASBACKÖFEN
-  GAS FRY TOP WITH GAS OVEN
-  PLAQUES GRILL A GAZ AVEC FOUR A GAZ





	7488.0680			
		800x900x850		120 / 180
		20 kW		✓
		8,5 kW		✓
		196		
		€ 5.295,-		

ACCESSORIES





	7488.9045		€ 36,-	
	>			
	7488.9050		€ 34,-	
	>			

GRID 2/1 GN

-  ROOSTER 2/1 GN
-  ROST 2/1 GN
-  GRID 2/1 GN
-  GRILLE 2/1 GN

	7488.9065			
		650x530x10		1
		€ 28,-		





ELECTRIC FRY TOP WITH ELECTRIC OVEN

-  EL. BAKPLAAT MET EL. OVEN
-  EL. GRILL PLATTE MIT EL. BACKÖFEN
-  EL. FRY TOP WITH EL. OVEN
-  PLAQUES GRILL EL. AVEC FOUR EL.



	7488.0685			
		800x900x850		120 / 180
		400 V / 15 kW		✓
		6 kW		✓
		196		
		€ 5.484,-		

GAS LAVA STONEGRILL

-  GAS LAVASTEENGRIL
-  GAS LAVASTEINGRILL
-  GAS LAVA STONE GRILL
-  GRILL PIERRE LAVIQUE GAZ





ELECTRIC GRILL

-  ELEKTRISCHE GRILL
-  ELEKTRO GRILL
-  ELECTRIC GRILL
-  GRILL ELECTRIQUE







BAIN-MARIE GAS







-  BAIN-MARIE GAS
-  BAIN-MARIE GAS
-  BAIN-MARIE GAS
-  BAIN-MARIE A GAZ









ELECTRIC BAIN-MARIE





-  ELEKTRISCHE BAIN-MARIE
-  ELEKTRO BAIN-MARIE
-  ELECTRIC BAIN-MARIE
-  BAIN-MARIE A ELECTRIQUE







	7488.0755
	400x900x850
	10 kW
	66
	€ 2.619,- 







	7488.0765
	400x900x850
	400 V / 7,5 kW
	80
	€ 2.552,- 









	7488.0760
	800x900x850
	20 kW
	108
	€ 3.902,- 

	7488.0770
	800x900x850
	400 V / 15 kW
	114
	€ 3.807,- 





	7488.0775
	400x900x250
	3 kW
	30 / 90
	GN 1x 1/1
	✓
	32
	€ 2.236,- 

	7488.0785
	400x900x250
	230 V / 2,2 kW
	30 / 90
	GN 1x 1/1
	✓
	32
	€ 2.090,- 

	7488.0780
	800x900x250
	6,2 kW
	30 / 90
	GN 2x 1/1
	✓
	65
	€ 2.560,- 





	7488.0790
	800x900x250
	400 V / 4,4 kW
	30 / 90
	GN 2x 1/1
	✓
	65
	€ 2.816,- 

GAS BOILING PAN





-  GAS KOOKKETEL Indirecte verhitting
-  GAS KOCHKESSEL Indirekt beheizt
-  GAS BOILING PAN Indirect heating
-  MARMITES À GAZ Chauffage indirect







ELECTRIC BOILING PAN





-  ELEKTRISCHE KOOKKETEL Indirecte verhitting
-  ELEKTRO KOCHKESSEL Indirekt beheizt
-  ELECTRIC BOILING PAN Indirect heating
- 



						€
7488.0795	800x900x850	14 kW	60	✓	140	7.482,-
7488.0800	800x900x850	21 kW	100	✓	160	9.183,-
7488.0805	800x900x850	24 kW	150	✓	141	9.329,-
7488.0810	800x900x850	230 V / 21 kW	100	AUTO	160	11.062,-
7488.0815	800x900x850	230 V / 24 kW	150	AUTO	160	10.967,-
7488.0855	1200x900x850	35 kW	240	✓	256	14.421,-





						€
7488.0820	800x900x850	400 V / 9,4 kW	60	✓	140	6.788,-
7488.0825	800x900x850	400 V / 21,5 kW	100	✓	135	8.456,-
7488.0830	800x900x850	400 V / 21,5 kW	150	✓	135	8.421,-
7488.0835	800x900x850	400 V / 21,5 kW	100	AUTO	160	9.501,-
7488.0840	800x900x850	400 V / 21,5 kW	150	AUTO	160	9.917,-

GAS BOILING PAN





-  GAS KOOKKETEL Directe verhitting
-  GAS KOCHKESSEL Direkt beheizt
-  GAS BOILING PAN Direct heating
-  MARMITES À GAZ Chauffage direct







ELECTRIC BOILING PAN





-  ELEKTRISCHE KOOKKETEL Directe verhitting
-  ELEKTRO KOCHKESSEL Direkt beheizt
-  ELECTRIC BOILING PAN Direct heating
-  MARMITES À ELECTRIQUE Chauffage direct



						€
7488.0845	800x900x850	21 kW	100	✓	135	7.328,-
7488.0850	800x900x850	24 kW	150	✓	135	7.414,-





						€
7488.0860	1200x900x850	400 V / 24 kW	250	✓	234	14.421,-

GAS MULTI COOKING PAN

-  GAS VARIPAN
-  GAS MULTI-BRÄTER
-  GAS MULTI COOKING PAN
-  MULTI-SAUTEUSE A GAZ







ELECTRIC MULTI COOKING PAN





-  EL. VARIPAN
-  ELEKTRO MULTI-BRATER
-  ELECTRIC MULTI COOKING PAN
-  MULTI-SAUTEUSE ELECTRIQUE



		€
7488.0865	800x900x850	6.091,-
	14 kW	
	100 / 250	
	115	



		€
7488.0870	800x900x850	5.905,-
	400 V / 10 kW	
	120 / 300	
	130	

GAS PASTA COOKER



-  GAS PASTAKOKER Excl. Manden
-  GAS NUDELKOCHER Exkl. Körbe
-  GAS PASTA COOKER Excl. Baskets
-  CUISEURS POUR PATES GAZ Excl. Paniers





ELECTRIC PASTA COOKER



-  ELEKTRISCHE PASTAKOKER Excl. Manden
-  ELEKTRO NUDELNKOCHER Exkl. Körbe
-  ELECTRIC PASTA COOKER Excl. Baskets
-  CUISEURS POUR PATES ELECTRIQUE Excl. Paniers



	7488.0875	7488.0885
	400x900x850	800x900x850
	16,5 kW	33 kW
GN	3x 1/3	6x 1/3
	62	115
€	4.096,-	6.907,-

	7488.0880	7488.0890
	400x900x850	800x900x850
	400 V / 10 kW	400 V / 20 kW
GN	3x 1/3	6x 1/3
	62	115
€	3.961,-	6.674,-







ACCESSORIES

	7488.9010	
	2x 1/2 GN	€ 269,-
	7488.9015	
	3x 1/3 GN	€ 330,-





GAS TILTING PAN

-  GAS KANTELBAARE BRAADSLEDE
Plaatstaal - Handmatige kanteling
-  GAS KIPBRATPFANNE
Stahlblech - Manuelles heben
-  GAS TILTING PAN
Sheet steel - Manual tilting
-  SAUTEUSE BASCULANTES A GAZ
Acier - Levage manual









	7488.0895	7488.0905
	800x900x850	1000x900x850
	230 V / 21 kW	230 V / 27 kW
	120 / 300	120 / 300
	80	100
	159	159
€	6.637,- 	6.782,- 





GAS TILTING PAN

-  GAS KANTELBAARE BRAADSLEDE
RVS - Handmatige kanteling
-  GAS KIPBRATPFANNE
Edelstahl - Manuelles heben
-  GAS TILTING PAN
Stainless Steel - Manual tilting
-  SAUTEUSE BASCULANTES A GAZ
Inox - Levage manual









	7488.0900	7488.0910
	800x900x850	1000x900x850
	230 V / 21 kW	230 V / 27 kW
	120 / 300	120 / 300
	80	100
	161	186
€	8.070,- 	9.115,- 





ELECTRIC TILTING PAN

-  EL. KANTELBAARE BRAADSLEDE
Plaatstaal - Handmatige kanteling
-  ELEKTRO-KIPBRATPFANNE
Stahlblech - Manuelles heben
-  ELECTRIC TILTING PAN
Sheet steel - Manual tilting
-  SAUTEUSE BASCULANTES ELECTRIQUE
Acier - Levage manual









	7488.0935	7488.0945
	800x900x850	1000x900x850
	400 V / 13 kW	400 V / 17 kW
	120 / 300	120 / 300
	80	100
	170	200
€	6.299,- 	5.918,- 





ELECTRIC TILTING PAN

-  EL. KANTELBAARE BRAADSLEDE
RVS - Handmatige kanteling
-  ELEKTRO-KIPBRATPFANNE
Edelstahl - Manuelles heben
-  ELECTRIC TILTING PAN
Stainless Steel - Manual tilting
-  SAUTEUSE BASCULANTES ELECTRIQUE
Inox - Levage manual









	7488.0940	7488.0950
	800x900x850	1000x900x850
	400 V / 13 kW	400 V / 17 kW
	120 / 300	120 / 300
	80	100
	157	182
€	7.844,- 	8.999,- 





GAS TILTING PAN

-  GAS KANTELBAARE BRAADSLEDE
Plaatstaal - Automatische kanteling
-  GAS KIPBRATPFANNE
Stahlblech - Automatische heben
-  GAS TILTING PAN
Sheet steel - Automatic tilting
-  SAUTEUSE BASCULANTES A GAZ
Acier - Levage automatique









	7488.0915	7488.0925
	800x900x850	1000x900x850
	230 V / 21 kW	230 V / 27 kW
	120 / 300	120 / 300
	80	100
	170	200
€	7.376,- 	8.051,- 





GAS TILTING PAN

-  GAS KANTELBAARE BRAADSLEDE
RVS - Automatische kanteling
-  GAS KIPBRATPFANNE
Edelstahl - Automatische heben
-  GAS TILTING PAN
Stainless Steel - Automatic tilting
-  SAUTEUSE BASCULANTES A GAZ
Inox - Levage automatique









	7488.0920	7488.0930
	800x900x850	1000x900x850
	230 V / 21 kW	230 V / 27 kW
	120 / 300	120 / 300
	80	100
	163	200
€	9.437,- 	10.479,- 





ELECTRIC TILTING PAN

-  EL. KANTELBAARE BRAADSLEDE
Plaatstaal - Automatische kanteling
-  ELEKTRO-KIPBRATPFANNE
Stahlblech - Automatische heben
-  ELECTRIC TILTING PAN
Sheet steel - Automatic tilting
-  SAUTEUSE BASCULANTES ELECTRIQUE
Acier - Levage automatique









	7488.0955	7488.0965
	800x900x850	1000x900x850
	400 V / 13 kW	400 V / 17 kW
	120 / 300	120 / 300
	80	100
	170	200
€	7.093,- 	7.047,- 

ELECTRIC TILTING PAN

-  EL. KANTELBAARE BRAADSLEDE
RVS - Automatische kanteling
-  ELEKTRO-KIPBRATPFANNE
Edelstahl - Automatische heben
-  ELECTRIC TILTING PAN
Stainless Steel - Automatic tilting
-  SAUTEUSE BASCULANTES ELECTRIQUE
Inox - Levage automatique







	7488.0960	7488.0970
	800x900x850	1000x900x850
	400 V / 13 kW	400 V / 17 kW
	120 / 300	120 / 300
	80	100
	157	200
€	9.218,- 	10.368,- 





NEUTRAL UNIT

-  NEUTRAAL ELEMENT
-  NEUTRAL ELEMENT
-  NEUTRAL UNIT
-  UNITÉ NEUTRAL







	7488.0990	7488.0995	7488.1000
	200x900x250	400x900x250	800x900x250
	20	40	80
€	524,- 	570,- 	861,- 

NEUTRAL UNIT DRAWER

-  NEUTRAAL ELEMENT LADE
-  NEUTRAL ELEMENT SCHUBLADEN
-  NEUTRAL UNIT DRAWER
-  UNITÉ NEUTRAL TIROIRS







	7488.0975	7488.0980	7488.0985
	200x900x250	400x900x250	800x900x250
	20	40	80
€	791,- 	888,- 	1.445,- 

SUPPORT

-  ONDERSTEL
-  UNTERBAU
-  SUPPORT
-  SOUBASSEMENT



	7488.1005	7488.1010	7488.1015
	400x785x600	800x785x600	1200x785x600
	40	80	120
€	513,- 	686,- 	824,- 

DOOR

-  DEUR
-  TÜR
-  DOOR
-  PORTE

	7488.9020
	> PRO700 / 900
	5
€	178,- 

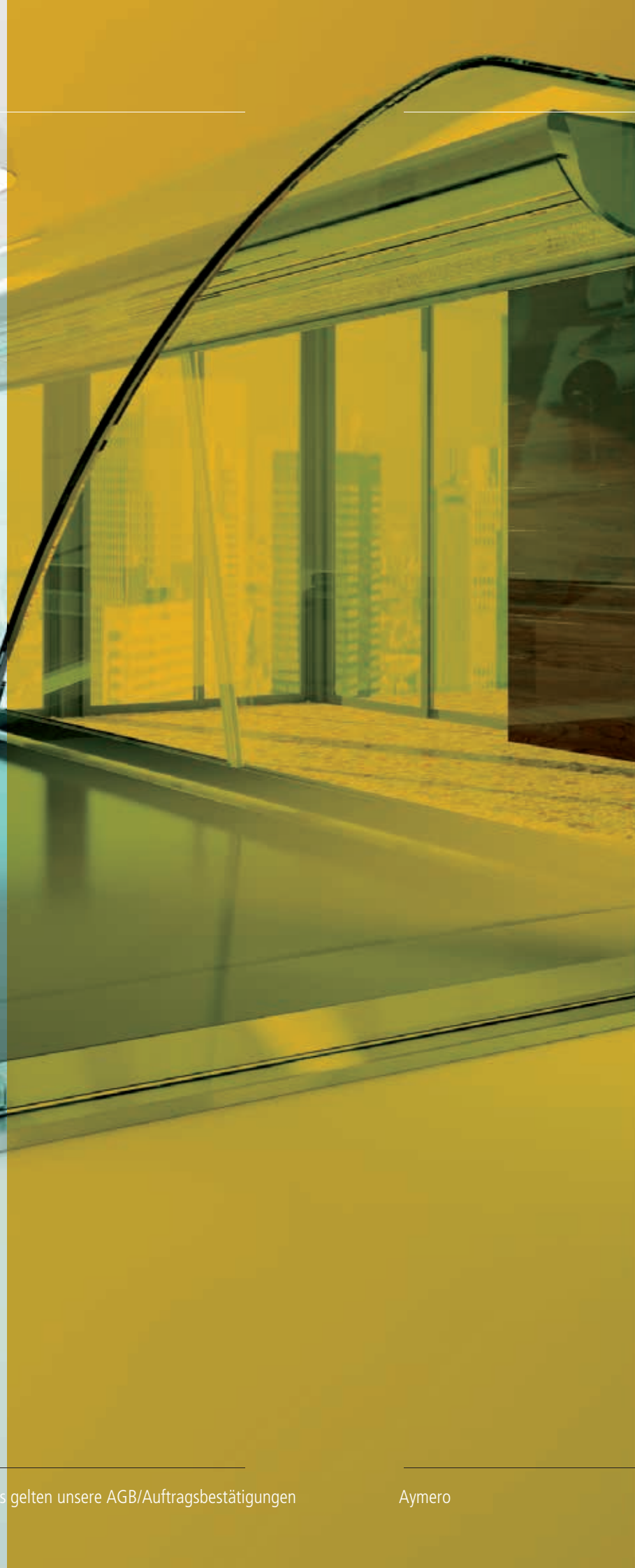

Drop-in
Drop-in
Drop-in
Drop-in



Cooking range

Drop-in

Ovens

Kitchen equipment

Refrigeration

Dishwashers

Neutral

Faucets

Ventilation







Pizzeria

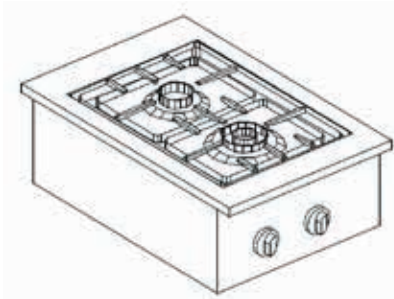

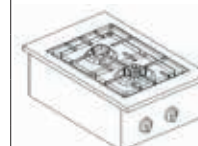



Bakery

GAS RANGE

-  GASKOOKUNIT
-  GASHERD
-  GAS RANGE
-  CUISINIÈRE A GAZ









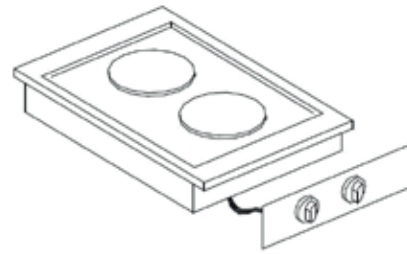

	7466.1601
	400x557
	380x537
	1x 3,5 / 1x 6 kW
	24
	€ 929,- 

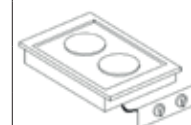







	7466.1606
	600x557
	580x537
	2x 6 / 2x 3,5 kW
	51,5
	€ 1.833,- 

ELECTRIC RANGE





-  ELEKTRISCHE KOOKUNIT
-  ELEKTROHERD
-  ELECTRIC RANGE
-  CUISINIÈRE ÉLECTRIQUE









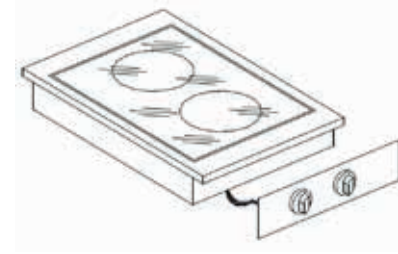

	7466.1610
	400x557
	380x537
	2x 180
	230 V 2x 2 kW
	14
	€ 564,- 

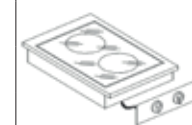







	7466.1615
	600x557
	580x537
	4x 180
	400 V 4x 2 kW
	28
	€ 798,- 

CERAMIC RANGE





-  KERAMISCHE KOOKUNIT
-  GLASKERAMIKHERD
-  CERAMIC RANGE
-  CUISINIÈRE EN CÉRAMIQUE











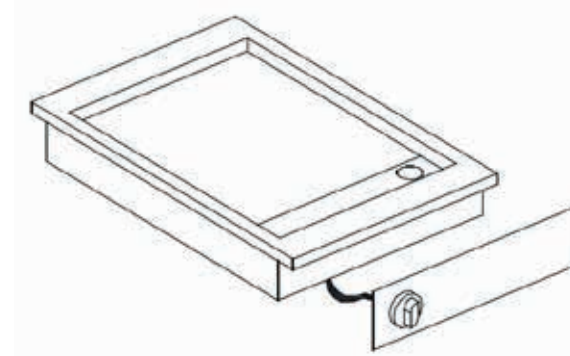



	7466.1620
	400x557
	380x537
	1x 180 1x 230
	230 V 1x 1,8 / 1x 2,5 kW
	24
	€ 1.291,- 

	7466.1625
	600x557
	580x537
	1x 180 2x 230 / 1x 145
	400 V 1x 1,8 kW 2x 3,5 kW 1x 2,5 kW
	46
	€ 1.916,- 





ELECTRIC FRY TOP

-  ELEKTRISCHE BAKPLAAT
-  ELEKTRO GRILLPLATTE
-  ELECTRIC FRY TOP
-  PLAQUES GRILL ÉLECTRIQUE









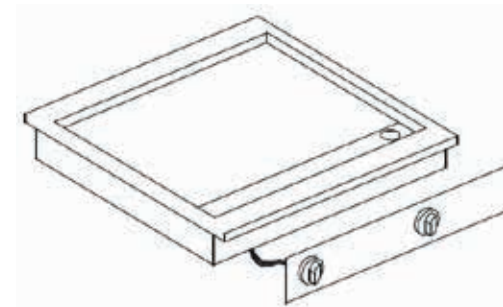

				SURFACE		€
7466.1645	388x516	348x482	230 V / 3,6 kW		25	902,- 
7466.1646	388x516	348x482	400 V / 3,6 kW		25	902,- 
7466.1647	388x516	348x482	230 V / 3,6 kW		25	1.214,- 
7466.1648	388x516	348x482	400 V / 3,6 kW		25	1.214,- 

ELECTRIC FRY TOP









-  ELEKTRISCHE BAKPLAAT
-  ELEKTRO GRILLPLATTE
-  ELECTRIC FRY TOP
-  PLAQUES GRILL ÉLECTRIQUE

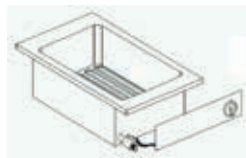

				SURFACE		€
7466.1650	588x516	548x482	400 V / 7,2 kW		41,2	1.328,- 
7466.1652	588x516	548x482	400 V / 7,2 kW		32	1.879,- 









ELECTRIC FRYER

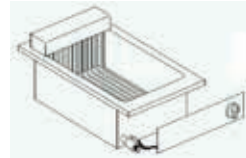







-  ELEKTISCHE FRITEUSE
-  ELEKTROFRITEUSEN
-  ELECTRIC FRYER
-  FRITEUSE ÉLECTRIQUE

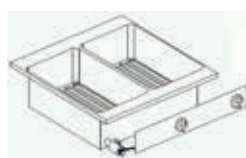







	7466.1630
	 400x557
	 380x537
	 6
	 230 V / 3,3 kW
	 16,4
 € 913,- 	

ELECTRIC FRYER





-  ELEKTISCHE FRITEUSE
-  ELEKTROFRITEUSEN
-  ELECTRIC FRYER
-  FRITEUSE ÉLECTRIQUE









	7466.1637
	 400x557
	 380x537
	 8
	 400 V / 5,3 kW
	 16,4
 € 1.182,- 	

	7466.1635
	 600x557
	 580x537
	 2x 6
	 230 V / 6,6 kW
	 33,5
 € 1.622,- 	





	7466.1638
	 600x557
	 580x537
	 2x 8
	 400 V / 12,6 kW
	 33,5
 € 2.102,- 	







ELECTRIC PASTA COOKER

-  ELEKTRISCHE PASTAKOKER
-  ELECTRO NUDELKOCHEER
-  ELECTRIC PASTA COOKER
-  CUISEURS POUR PÂTES ÉLECTRIQUE

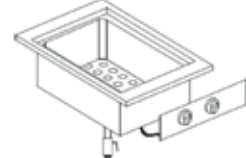

	7466.1660
	 600x557
	 580x537
	 26
	 400 V / 5,5 kW
	 35
 € 1.808,- 	

BAIN-MARIE UNIT









-  BAIN-MARIE ELEMENT
-  BAIN-MARIE MODULE
-  BAIN-MARIE UNIT
-  ELEMENT DE BAIN-MARIE

	7466.1640
	 400x557
	 380x537
	GN 1/2 + 1/4 GN
	 230 V / 1,4 kW
	 17
 € 780,- 	





BAIN-MARIE UNIT

-  BAIN MARIE UNIT
-  BAIN MARIE MODULE
-  BAIN-MARIE UNIT
-  ELEMENT DE BAIN MARIE









		GN			€
7427.0050	805x635x380	2 x 1/1	230 V / 2 kW	33	1.418,- 
7427.0055	1135x635x380	3 x 1/1	400 V / 3 kW	40	1.856,- 
7427.0060	1455x635x380	4 x 1/1	400 V / 4 kW	47	2.052,- 
7427.0061	1780x635x380	5 x 1/1	400 V / 5 kW	54	2.351,- 
7427.0062	2105x635x380	6 x 1/1	400 V / 6 kW	61	2.668,- 

GLASS-CEREMIC HEATING TOP UNIT

-  KERAMISCHE WARMHOUDPLAAT
-  GLASKERAMIK WARMHALTPLATTE
-  GLASS-CEREMIC HEATING TOP UNIT
-  PLAQUE CHAUFFANTE VITROCERAMIQUE











				€
7427.0065	805x635x190	230 V / 1,2 kW	33	1.585,- 
7427.0070	1135x635x190	230 V / 1,8 kW	40	1.863,- 
7427.0075	1455x635x190	230 V / 2,4 kW	47	2.046,- 

REFRIGERATED UNIT

-  GEKOELDE BAK
-  GEKÜHLTEM BECKEN
-  REFRIGERATED UNIT
-  CUVE RÉFRIGÉRÉE











		GN				€
7427.0003	805x635x670	2 x 1/1	230 V / 0,5 kW	+4/ +10	55	2.546,- 
7427.0002	1135x635x670	3 x 1/1	230 V / 0,5 kW	+4/ +10	65	2.937,- 
7427.0001	1455x635x670	4 x 1/1	230 V / 0,5 kW	+4/ +10	75	3.144,- 
7427.0007	1780x635x670	5 x 1/1	230 V / 0,6 kW	+4/ +10	85	3.652,- 
7427.0008	2105x635x670	6 x 1/1	230 V / 0,6 kW	+4/ +10	95	4.302,- 

REFRIGERATED TOP UNIT

-  GEKOELDE PLAAT
-  GEKÜHLTE PLATTE
-  REFRITERATED TOP UNIT
-  PLAQUE RÉFRIGÉRÉE



		GN				€
7427.0125	805x635x480	2 x 1/1	230 V / 0,5 kW	-3/-10	45	2.278,- 
7427.0130	1135x635x480	3 x 1/1	230 V / 0,5 kW	-3/-10	55	2.635,- 
7427.0135	1455x635x480	4 x 1/1	230 V / 0,5 kW	-3/-10	65	2.814,- 
7427.0136	1780x635x480	5 x 1/1	230 V / 0,6 kW	-3/-10	75	3.483,- 
7427.0137	2105x635x480	6 x 1/1	230 V / 0,6 kW	-3/-10	85	4.090,- 

Cooking range

Drop-in

Ovens

Kitchen equipment

Refrigeration

Dishwashers

Neutral





Faucets

Ventilation





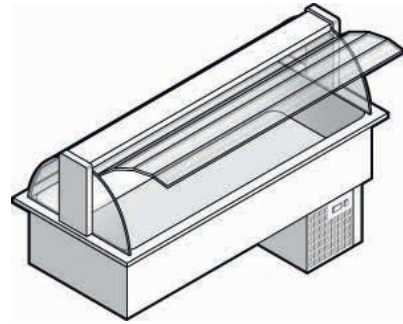

Pizzeria

Bakery





ELECTRIC FRYER

-  GEKOELDE BAK MET VITRINE
-  GEKÜHLTEM BECKEN MIT VITRINE
-  REFRIGERATED CONTAINER WITH DISPLAY
-  CUVE RÉFRIGÉRÉE AVEC VITRINE







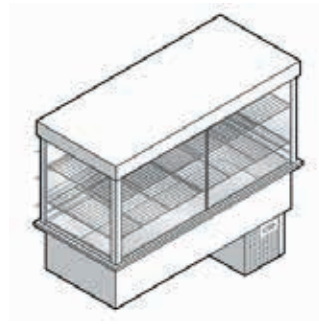

	7427.0940	7427.0945
	1135x635x920	1455x635x920
	+4 / +10	+4 / +10
GN	3x 1/1	4x 1/1
	230 V / 0,5 kW	230 V / 0,5 kW
	41	48
€	4.941,- 	5.153,- 





ELECTRIC FRYER

-  GEKOELDE BAK MET DISPLAY
-  GEKÜHLTEM BECKEN MIT VITRINE
-  REFRIGERATED CONTAINER WITH DISPLAY
-  CUVE RÉFRIGÉRÉE AVEC VITRINE









	7427.0140	7427.0145
	1135x635x920	1455x635x920
	+4/+10	+4/+10
GN	3x 1/1	4x 1/1
	230 V / 0,5 kW	230 V / 0,5 kW
	45	52
€	5.240,- 	6.552,- 





DISPLAY COUNTER WITH LIGHTINGELEMENT AND SLIDING DOORS

-  VITRINE MET LICHELEMENT EN SCHUIFDEUREN
-  VITRINE MIT BELEUCHTUNGSELEMENT UND SCHIEBETÜREN
-  DISPLAY COUNTER WITH LIGHTINGELEMENT AND SLIDING DOORS
-  VITRINE AVEC ÉLÉMENT ENCLAIRANT AVEC PORTES COULISSANTES









	7427.1050	7427.1055	7427.1060
	762x630x460	1087x630x460	1440x630x460
	230 V / 0,02 kW	230 V / 0,02 kW	230 V / 0,04 kW
	10	12	14
€	1.478,- 	1.570,- 	1.694,- 





DISPLAY COUNTER WITH HEATINGELEMENT AND SLIDING DOORS

-  VITRINE MET WARMTE ELEMENT EN SCHUIFDEUREN
-  VITRINE MIT HEIZELEMENT UND SCHIEBETÜREN
-  DISPLAY COUNTER WITH HEATINGELEMENT AND SLIDING DOORS
-  VITRINE AVEC ÉLÉMENT CHAUFFANT ET PORTES COULISSANTES







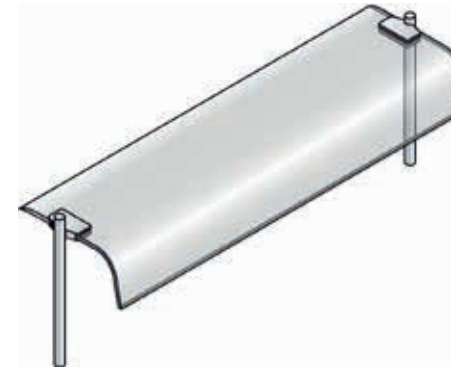

	7427.1065	7427.1070	7427.1075
	762x630x460	1087x630x460	1440x630x460
	230 V / 0,4 kW	230 V / 0,8 kW	230 V / 1,2 kW
	11	13	15
€	1.570,- 	1.660,- 	1.784,- 





OVERSHELF WITH CURVED GLASS

-  GLASBRUG MET GEBOGEN GLASPLAAT
-  AUFZATSBORD MIT ABGERUNDEN GLAS
-  OVERSHELF WITH CURVED GLASS
-  SUPERSTRUCTURE AVEC VITRINE COURBÉ







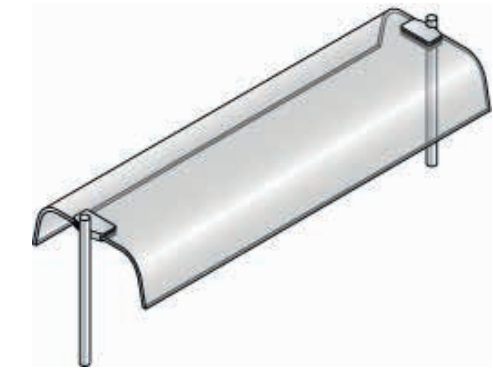

	> L			€
7427.0975	805	785x360x400	4	576,- 
7427.0980	1135	1110x360x400	5	594,- 
7427.0985	1455	1440x360x400	6	621,- 
7427.0990	1780	1765x460x400	7	771,- 
7427.0995	2105	2090x460x400	8	986,- 





OVERSHELF WITH DOUBLE CURVED GLASS

-  GLASBRUG MET 2 GEBOGEN GLASPLATEN
-  AUFZATSBORD MIT DOPPELT ABGERUNDEN GLAS
-  OVERSHELF WITH DOUBLE CURVED GLASS
-  SUPERSTRUCTURE AVEC VITRE DOUBLE COURBÉ







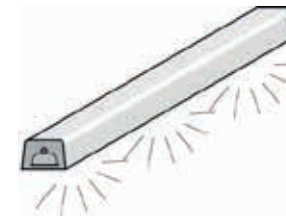

	> L			€
7427.0950	805	785x360x400	7	587,- 
7427.0955	1135	1110x360x400	9	607,- 
7427.0960	1455	1440x360x400	11	634,- 
7427.0965	1780	1765x460x400	13	786,- 
7427.0970	2105	2090x460x400	15	1.007,- 





LIGHTING ELEMENT FOR OVERSHELF

-  LICHELEMENT VOOR GLASBRUG
-  BELEUGTUNGS ELEMENT FÜR AUFZATSBORD
-  LIGHTING ELEMENT FOR OVERSHELF
-  ELÉMENT CLAIRANT POUR SUPERSTRUCTURE







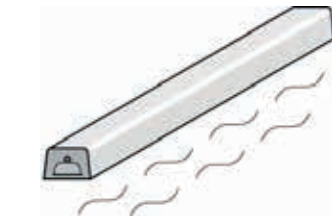

	L			€
7427.1000	805	230V / 0,01 kW	1	398,- 
7427.1005	1135	230V / 0,01 kW	1.5	424,- 
7427.1010	1455	230V / 0,02 kW	2	448,- 
7427.1015	1780	230V / 0,03 kW	2.5	549,- 
7427.1020	2105	230V / 0,04 kW	3	703,- 





HEATING ELEMENT FOR OVERSHELF

-  WARMTE ELEMENT VOOR GLASBRUG
-  WARMTESTRAHLER FÜR AUFZATSBORD
-  HEATING ELEMENT FOR OVERSHELF
-  ELÉMENT CHAUFFANT POUR SUPERSTRUCTURE







	L			€
7427.1025	805	230V / 0.4 kW	1	486,- 
7427.1030	1135	230V / 0.8 kW	1,5	504,- 
7427.1035	1455	230V / 0.8 kW	2	522,- 
7427.1040	1780	230V / 1.2 kW	2,5	640,- 
7427.1045	2105	230V / 1.6 kW	3	820,- 





NEUTRAL PLATES LIFT

-  BORDENLIFT
-  TELLERSPENDER
-  NEUTRAL PLATES LIFT
-  SOULEVER D'ASSIETTES NEUTRE









	7427.0345	7427.0350
 H	Ø 400	Ø 470
 Ø	180-260	210-290
 €	572,- 	621,- 

WARM PLATES LIFT

-  VERWARMDE BORDENLIFT
-  WARMTELLER SPENDER
-  WARM PLATES LIFT
-  SOULEVER D'ASSIETTES CHAUD







	7427.0355	7427.0360
 H	Ø 400	Ø 470
 Ø	180-260	210-290
	230 v / 0,4 kW	230 v / 0,4 kW
 €	1.149,- 	1.291,- 

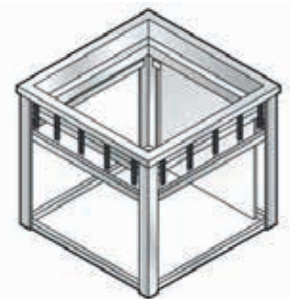



CONTAINERS LIFT

-  DIENBLADENLIFT
-  KISTENHEBER
-  CONTAINERS LIFT
-  SOULEVER DE PANIER











	7427.0365	7427.0370
 H	640x600x580	660x460x580
 D	500 x 500	530 x 370
 €	1.691,- 	1.907,- 

REFRIGERATED DROP IN UNIT

-  GEKOELDE BAK
-  GEKÜHLTEM BECKEN
-  REFRIGERATED DROP IN UNIT
-  CUVE RÉFRIGÉRÉE











	7478.1000	7478.1005
 H	1042x595x650	1362x595x650
 D	990x550	1310x550
 °C	+2/+8	+2/+8
GN	1x 3/1	1x 4/1
	230 V / 0,537 kW	230 V / 0,544 kW
 KG	54	57
 €	1.249,- 	1.460,- 





HEATED DROP IN UNIT

-  BAIN MARIE UNIT
-  BEHEIZTE BECKEN
-  HEATED DROP IN UNIT
-  CUVE CHAUFFÉE



	7478.1010	7478.1015
 H	1042x595x260	1362x595x260
 D	990x550	1310x550
 °C	+30/+90	+30/+90
GN	1x 3/1	1x 4/1
	230 V / 2x 0,8 kW	230 V / 3x 0,8 kW
 KG	15	19
 €	869,- 	1.235,- 





OVERSHELF WITH LIGHTING

-  VERLICHTE GLASBRUG
-  AUFZATSBORD MIT BELEUCHTUNG
-  OVERSHELF WITH LIGHTING
-  SUPERSTRUCTURE AVEC ÉCLAIRAGE







	L	D	H	⚡	€
7478.1020	1370	310	120/520	230 V	410,- 
7478.1025	1670	310	120/520	230 V	449,- 
7478.1030	1990	310	120/520	230 V	492,- 
7478.1035	2400	310	120/520	230 V	533,- 

OVERSHELF WITH HEATING

-  VERWARMDE GLASBRUG
-  BEHEIZTE AUFZATSBORD
-  OVERSHELF WITH HEATING
-  SUPERSTRUCTURE AVEC CHAUFFAGE



	L	D	H	⚡	€
7478.1040	1370	310	120/520	230 V / 2X 0,15 kW	395,- 
7478.1045	1670	310	120/520	230 V / 3X 0,15 kW	415,- 
7478.1050	1990	310	120/520	230 V / 4X 0,15 kW	445,- 
7478.1055	2400	310	120/520	230 V / 4X 0,15 kW	475,- 

Cooking range

Drop-in

Ovens

Kitchen equipment

Refrigeration

Dishwashers

Neutral

Faucets

Ventilation

Pizzeria

Bakery











Ovens
 Backofen
Ovens
 Fours





MICROWAVE

-  MAGNETRON
-  MICROWELLE
-  MICROWAVE
-  MICRO-ONDES









	7455.1660
	574x528x368
	360x409x225
	34
	230 V / 3,2 kW 50 Hz / 2100 W
	34,3
	€ 999,- 

CONVECTION OVEN WITH HUMIDIFIER

-  CONVECTIEOVEN MET BEVOCHTIGER
-  KONVEKTIONÖFEN MIT BESCHWADUNG
-  CONVECTION OVEN WITH HUMIDIFIER
-  FOUR À CONVECTION AVEC HUMIDIFICATEUR







	7484.0040
	600x600x540
	+30/+260
TRAYS	4 x 480x345
	230 V / 3,3 kW
	37
	€ 841,- 





CONVECTION OVEN

-  CONVECTIEOVEN
-  KONVEKTIONÖFEN
-  CONVECTION OVEN
-  FOUR À CONVECTION









	7484.0010
	550x605x540
	+50/+260
TRAYS	4 x 442X325
	230 V / 2,6 kW
	21
	€ 575,- 



CONVECTION OVEN WITH HUMIDIFIER





-  CONVECTIEOVEN MET BEVOCHTIGER
-  KONVEKTIONÖFEN MIT BESCHWADUNG
-  CONVECTION OVEN WITH HUMIDIFIER
-  FOUR À CONVECTION AVEC HUMIDIFICATEUR







	7484.0005
	550x605x540
	+50/+280
TRAYS	4 x 442X325
	230 V / 2,6 kW
	53
	€ 715,- 

ACCESSORIES

-  ACCESSOIRES ROOSTER
-  ACCESSOIRES EINLEGEROST
-  ACCESSOIRES GRID
-  ZUBEHOR GRILLE

	7484.1055
	442x325
	€ 14,- 





CONVECTION OVEN DROP DOWN GN

-  CONVECTIEOVEN DROP DOWN GN
-  KONVEKTIONÖFEN DROP DOWN GN
-  CONVECTION OVEN DROP DOWN GN
-  FOUR À CONVECTION DROP DOWN GN



	7466.0250
	770x740x600
	+50/+280
GN	3 x 1/1 GN
	230 V / 3,3 kW
	53
	€ 1.610,- 



CONVECTION OVEN DROP DOWN GN OR EN









-  CONVECTIEOVEN DROP DOWN GN OF EN
-  KONVEKTIONÖFEN DROP DOWN GN ODER EN
-  CONVECTION OVEN DROP DOWN GN OR EN
-  FOUR À CONVECTION DROP DOWN GN OU EN



	7466.0260
	770x740x650
	+50/+280
GN	4 x 1/1 GN
EN	4x 600x400
	400 V / 6,3 kW
	63
	€ 1.915,- 

ACCESSORIES

-  ACCESSOIRES ROOSTER
-  ACCESSOIRES EINLEGEROST
-  ACCESSOIRES GRID
-  ZUBEHOR GRILLE

	7045.0011
GN	1/1 GN
	530x325
	€ 19,- 
	7045.0012
GN	2/3 GN
	354x325
	€ 25,- 



Cooking range

Drop-in

Ovens

Kitchen equipment

Refrigeration

Dishwashers

Neutral

Faucets

Ventilation

Pizzeria

Bakery

CONVECTION OVEN







-  CONVECTIEOVEN
-  KONVEKTIONÖFEN
-  CONVECTION OVEN
-  FOUR À CONVECTION









CONVECTION OVEN

-  CONVECTIEOVEN
-  KONVEKTIONÖFEN
-  CONVECTION OVEN
-  FOUR À CONVECTION







	7466.0092
	650x600x530
	+50 / +280
GN	4 x 2/3 GN
	230 V / 2,6 kW
	24
€	1490,- 

	7466.0094
	870x730x600
	+50 / +280
GN	4x 1/1 GN
	400 V / 6,3 kW
	64
€	2.599,- 







STAND WITHOUT RUNNERS SET

-  ONDERSTEL ZONDER GELEIDERSET
-  UNTERGESTEL ONHE FÜHRUNGSSCHIENEN
-  STAND WITHOUT RUNNERS SET
-  SUPPORT SANS SÉRIE DE GLISSIÈRES

	7466.0110
>	7466.0092-7466.0094
	830x570x850
GN	5x 1/1GN
	31
€	625,- 



CORE PROBE KIT

-  KERN TEMPERATUURMETER
-  KERNFÜHLER KIT
-  CORE PROBE KIT
-  KIT DE SONDE À COEUR



	7466.0095
	0,5
€	185,- 







RUNNERS SET

-  GELEIDERSET
-  FÜHRUNGSSCHIENEN
-  RUNNERS SET
-  SÉRIE DE GLISSIÈRES





	7466.0124
GN	5x 1/1GN
	22
€	225,- 

ACCESSORIES

-  ACCESSOIRES ROOSTER
-  ACCESSOIRES EINLEGEROST
-  ACCESSORIES GRID
-  ZUBEHOR GRILLE

	7045.0011
GN	1/1 GN
	530x325
€	19,- 
	7045.0012
GN	2/3 GN
	354x325
€	25,- 

CONVECTION OVEN HUMIDIFIER AND TWO SPEED FAN





-  CONVECTIEOVEN BEVOCHTIGER EN MOTOR MET TWEE SNELHEDEN
-  KONVEKTIONÖFEN BESCHWADUNG UND DOPPELTE MOTOR GESCHWINDIGKEIT
-  CONVECTION OVEN HUMIDIFIER AND TWO SPEED FAN
-  FOUR À CONVECTION HUMIDIFICATEUR ET DOUBLE VITESSE



	H	°C	GN	EN	⚡	KG	€
7466.0005	650x600x530	+50 / +280	4 x 2 / 3 GN	X	230 V / 2,6 kW	24	1.725,-
7466.0010	870x730x600	+50 / +280	5 x 1 / 1 GN	600x400	400 V / 6,3 kW	67	2.950,-
7466.0015	870x770x700	+50 / +280	5 x 1 / 1 GN	600x400	230 V / 0,4+9,5 kW	120	4.525,-
7466.0025	870x730x980	+50 / +280	10 x 1 / 1 GN	600x400	400 V / 12,6 kW	100	4.160,-
7466.0030	870x770x1080	+50 / +280	10 x 1 / 1 GN	600x400	230 V / 0,9+19 kW	160	5.925,-



STAND WITHOUT RUNNERS SET

-  ONDERSTEL ZONDER GELEIDERSET
-  UNTERGESTEL ONHE FÜHRUNGSSCHIENEN
-  STAND WITHOUT RUNNERS SET
-  SUPPORT SANS SÉRIE DE GLISSIÈRES





	7466.0110	7466.0115
>	7466.0010 7466.0015	7466.0025 7466.0030
H	830x570x850	830x570x700
GN	5X1/1GN	10X1/1GN
KG	31	28
€	625,-	625,-

RUNNERS SET

-  GELEIDERSET
-  FÜHRUNGSSCHIENEN
-  RUNNERS SET
-  SÉRIE DE GLISSIÈRES

	7466.0124	7466.0127
GN	5X1/1GN	10X1/1GN
KG	22	23
€	225,-	225,-



CORE PROBE KIT

-  KERN TEMPERATUURMETER
-  KERNFÜHLER KIT
-  CORE PROBE KIT
-  KIT DE SONDE À COEUR





	7466.0095
KG	0,5
€	185,-

ACCESSORIES





-  ACCESSOIRES
-  ACCESSORIES
-  ACCESSORIES
-  ZUBEHOR

	7045.0011	GN	1/1 GN	H	530x325	€	19,-
	7045.0012	GN	2/3 GN	H	354x325	€	25,-
	7045.0007	EN	600x400			€	29,-

CONVECTION/STEAMOVEN





-  CONVECTIE/STOOMOVEN
-  KONVEKTION/DAMPFBACKÖFEN
-  CONVECTION/STEAMOVEN
-  FOUR À CONVECTION/VAPEUR





			GN			€
7466.0065	870x730x600	+50 / +280	5x 1/1GN	400 V / 6,3 kW	75	3.811,-
7466.0070	870x770x700	+50 / +280	5x 1/1GN	230 V / 0,3+9,5 kW	120	5.640,-
7466.0080	870x730x980	+50 / +280	10x 1/1GN	400 V / 12,6 kW	110	5.550,-
7466.0085	870x770x71080	+50 / +280	10x 1/1GN	230 V / 0,6+19 kW	160	7.200,-







STAND WITHOUT RUNNERS SET

-  ONDERSTEL ZONDER GELEIDERSET
-  UNTERGESTEL ONHE FÜHRUNGSSCHIENEN
-  STAND WITHOUT RUNNERS SET
-  SUPPORT SANS SÉRIE DE GLISSIÈRES

	7466.0110	7466.0115
	7466.0065 7466.0070	7466.0080 7466.0085
	830x570x850	830x570x700
GN	5X1/1GN	10X1/1GN
	31	28
€	625,-	625,-



CORE PROBE KIT

-  KERN TEMPERATUURMETER
-  KERNFÜHLER KIT
-  CORE PROBE KIT
-  KIT DE SONDE À COEUR

	7466.0095
	7466.0095
	0,5
€	185,-



RUNNERS SET

-  GELEIDERSET
-  FÜHRUNGSSCHIENEN
-  RUNNERS SET
-  SÉRIE DE GLISSIÈRES





	7466.0124	7466.0127
	7466.0124	7466.0127
GN	5X1/1GN	10X1/1GN
	22	23
€	225,-	225,-

ACCESSORIES







-  ACCESSOIRES
-  ACCESSOIRES
-  ACCESSOIRES
-  ZUBEHOR

	7045.0011	GN 1/1 GN		530x325	€ 19,-
	7045.0007	EN 600x400			€ 29,-

CONVECTION/STEAMOVEN with touch screen





-  CONVECTIE/STOOMOVEN met touchscreen
-  KONVEKTION/DAMPFBÄCKÖFEN mit sensorbildschirm
-  CONVECTION/STEAMOVEN with touch screen
-  FOUR À CONVECTION/VAPEUR avec écran tactile

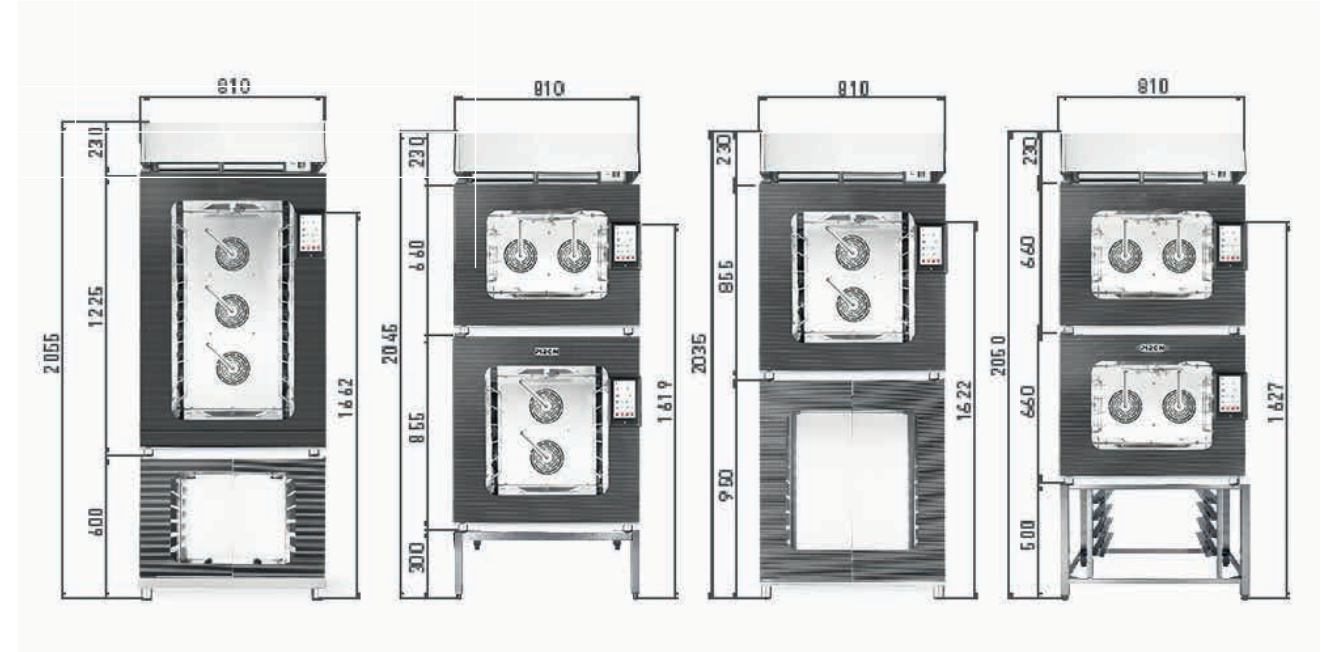





			GN	EN			€
7484.0015	810x895x660	+30 / +260	4x 1/1GN	4x 600x400	400 V / 9,6 kW	90	5.600,- 
7484.0020	810x895x855	+30 / +260	4x 1/1GN	6x 600x400	400 V / 9,7 kW	110	6.200,- 
7484.0025	810x895x1225	+30 / +260	10x 1/1GN	10x 600x400	400 V / 14,5 kW	125	7.300,- 







STAND FOR OVEN





-  ONDERSTEL VOOR OVEN
-  UNTERGESTELL FÜR OFEN
-  STAND FOR OVEN
-  SUPPORT POUR FOUR







	7812.2005	7812.2010
	900x800x700	900x800x900
	25	35
€	499,- 	505,- 

PROOFER



-  RIJSKAST
-  GÄRSCHRANK
-  PROOFER
-  ARMOIRE DE FERMENTATION

7484.0030	
	810x800x950
	+30 / +60
GN	8x 1/1 GN
EN	8x 600x400
	230 V / 2 kW
	50
€	1.260,- 

7484.0035	
	810x940x600
	+30 / +60
GN	12x 1/1 GN
EN	12x 600x400
	230 V / 2 kW
	50
€	1.260,- 

GRID EN

-  ROOSTER EN
-  ROST EN
-  GRID EN
-  GRILLE EN





	7045.0007	
	 H	600x400
	EN	600x400
	€	29,- 

BAGUETTE TRAY

-  STOKBROODREK
-  BAGUETTE PLATTE
-  BAGUETTE TRAY
-  BAGUETTE PLATEAU

	7484.1005	
	 H	600x400
	€	46,- 

STEEL PIZZA TRAY

-  STALEN PIZZA PLAAT
-  EDELSTAHL PIZZA PLATTE
-  STEEL PIZZA TRAY
-  PLATEAU EN ACIER POUR PIZZA

	7484.1020	
	 H	600x400x20
	€	22,- 

GN CONTAINER

-  GN PAN
-  GN BEHÄLTER
-  GN CONTAINER
-  GN RÉCIPENT





	7476.0050	
	 H	530x325x20
	GN	1/1 GN
	€	11,- 

SHOWER FOR OVEN

-  DOUCHE TBV OVEN
-  DUSCHE FÜR OFEN
-  SHOWER FOR OVEN
-  DOUCHE POUR FOURS

	7484.1030	
	€	110,- 

OVEN DETERGENT

-  OVENREINIGER
-  OFEN REINIGUNGSMITTEL
-  OVEN DETERGENT
-  DÉTERGENT DE FOURS





	7484.1045	
	 H	0,75
	€	10,- 

GRID GN

-  ROOSTER GN
-  EINLEGEROST GN
-  GRID GN
-  GRILLE GN





	7045.0011	
	 H	530x325
	GN	1/1 GN
	€	19,- 



ALUMINIUM PERFORATED TRAY

-  ALUMINIUM GEPERFOREERDE PLAAT
-  ALUMINIUM PERFORIERTE PLATTE
-  ALUMINIUM PERFORATED TRAY
-  ALUMINIUM PLATEAU PERFORÉE

	7484.1010	
	 H	600x400x20
	€	34,- 

SS CHICKED GRID

-  RVS KIPPENREK
-  EDELSTAHL HÜHNEN ROST
-  SS CHICKED GRID
-  GRILLE DU POULET EN INOX

	7484.1025	
	 H	530x325
	GN	1/1 GN
	€	75,- 

GN CONTAINER

-  GN PAN
-  GN BEHÄLTER
-  GN CONTAINER
-  GN RÉCIPENT





	7476.0055	
	 H	530x325x40
	GN	1/1 GN
	€	13,- 

OVEN RINSE

-  OVENSPOELMIDDEL
-  OVENS PÜLUNG
-  OVEN RINSE
-  RINÇAGE DE FOURS

	7484.1035	
	 H	5
	€	52,- 

WATER SOFTNER

-  WATERONTHARDER
-  WASSERENTHÄRTER
-  WATER SOFTNER
-  ADOUCISSEUR D'eau





	7484.1050	
	 H	3500
	€	280,- 

ALUMINIUM TRAY

-  ALUMINIUM PLAAT
-  ALUMINIUM PLATTE
-  ALUMINIUM TRAY
-  ALUMINIUM PLATEAU

	7484.1000	
	 H	600x400x20
	€	26,- 

ALUMINIUM TEFLON TRAY

-  ALUMINIUM TEFLON PLAAT
-  ALUMINIUM TEFLON PLATTE
-  ALUMINIUM TEFLON TRAY
-  ALUMINIUM PLATEAU TEFLON

	7484.1015	
	 H	600x400x20
	€	54,- 

GN CONTAINER

-  GN PAN
-  GN BEHÄLTER
-  GN CONTAINER
-  GN RÉCIPENT

	7476.0060	
	 H	530x325x65
	GN	1/1 GN
	€	14,- 

OVEN DETERGENT

-  OVENREINIGER
-  OFEN REINIGUNGSMITTEL
-  OVEN DETERGENT
-  DÉTERGENT DE FOURS

	7484.1040	
	 H	6
	€	55,- 



Cooking range

Drop-in

Ovens

Kitchen equipment

Refrigeration

Dishwashers

Neutral

Faucets

Ventilation

Pizzeria

Bakery



Keukenapparatuur
Küchengeräte
Kitchen Equipment
Appareil de cuisson

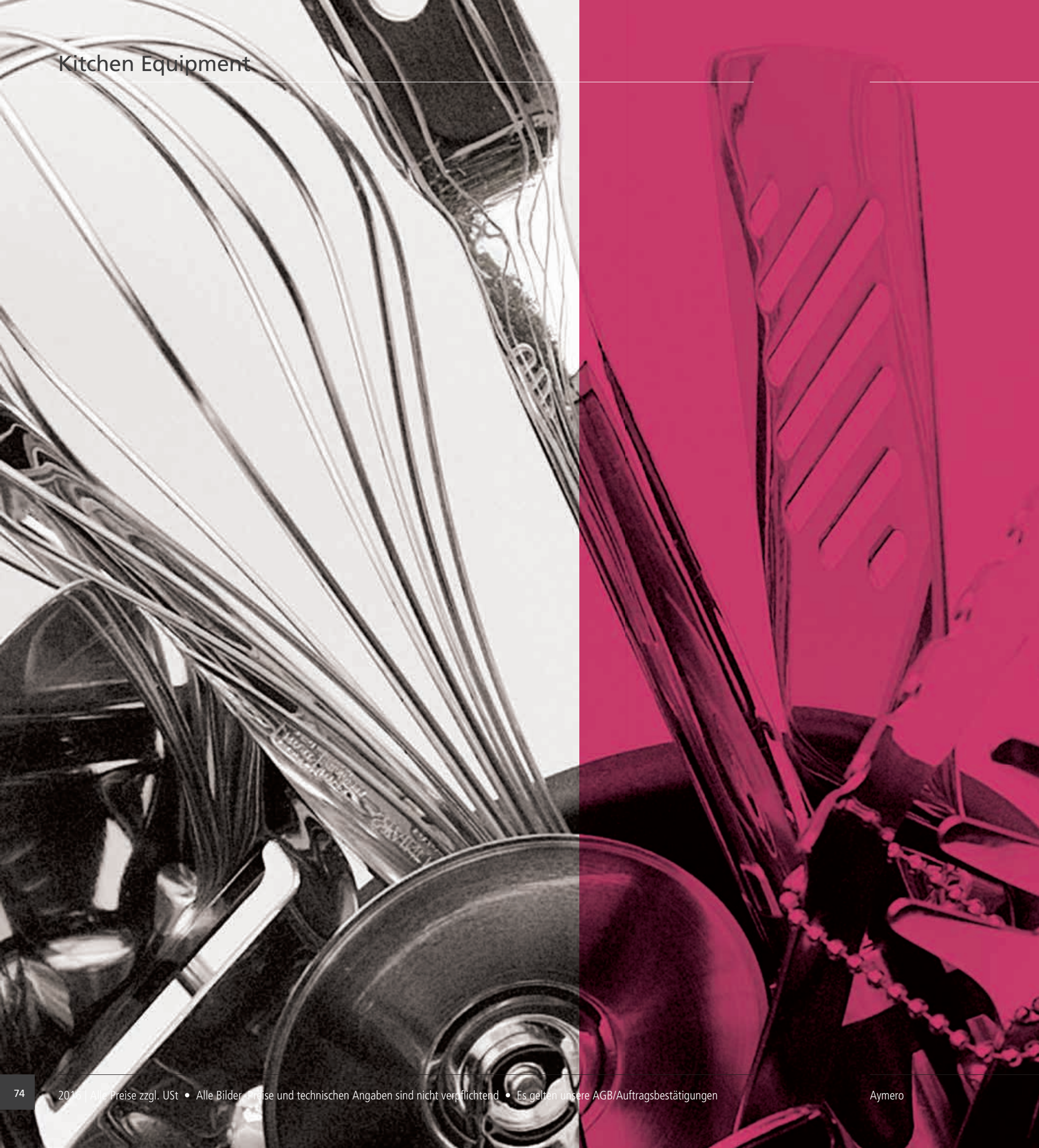

FRYING COUNTER

 BAKWAND

De Combisteel bakwand heeft drie gasgestookte frituurpotten met een capaciteit van 18 kW per stuk. Deze bakwanden zijn in een korte tijd een begrip geworden in de snackwereld. De bankwand is vervaardigd van hoogwaardig roestvrijstaal. De bediening van de bakwand is zeer eenvoudig. Onder iedere frituurpot bevindt zich een vetvanglade. Deze kan alleen verwijderd worden als de vetkraan gesloten is, zodat het verven van het frituurvet veilig en verantwoord gebeurt. Het blad en de bovenbouw zijn naadloos uitgevoerd. Onder de patatvoorraadbak bevindt zich de randafzuiging. Optioneel is de bakwand te leveren op propaangas. De bakwand is ook geschikt om in te bouwen in een snackwagen. Zo is hij ideaal te gebruiken tijdens drukke evenementen door de hoge capaciteit.

 FRITTIER ANLAGE

Der Combisteel Frittier Anlage hat drei Gas Frittierpfanne mit einer Kapazität von 18 kW/Stück. Diese Backwände sind ein Begriff in der Backwelt. Die Frittier Anlage ist aus hochwertigem Edelstahl Stahl hergestellt und die Bedienung der Backwand ist ganz einfach. Unter jedem Frittierpfanne befindet sich eine Schublade für das Fett. Diese Schublade kann nur entfernt werden wenn die Fettablasshahn geschlossen ist. Auf diese Weise können Sie das Fett sicher und verantwortlich erneuern. Das Blatt und der Oberbau sind nahtlos ausgeführt. Unter dem Vorratbehälter für die Pommes befindet sich die Abzug. Nach Wahl kann die Backwand auf Propangas geliefert werden. Eingebaut in einer Wagen ist diese Fachwand durch ihre hohe Backkapazität ideal für Festivals und Ereignissen wegen die hohe Kapazität.

 FRYING COUNTER

The Combisteel frying counter has three deep frying pans with a capacity of 18 kW each. These frying counters have required a very good name in the baking world. The frying counter is made of high quality stainless steel and is very easy to operate. Under each deep frying pan there is a tray for grease, which can only be removed when the grease valve is closed. This way the grease can be changed safely and responsibly. The counter top and the upper part are seamless. The exhaust is installed underneath the chips storage. Optionally the baking wall is available on propane gas. The counter fryer can be installed in a food truck which makes it ideal to use during events or festivals because of its high capacity.

 PAROI DE CUISSON

Le paroi de cuisson Combisteel a trois échangeurs de gaz profonds d'une capacité de 18 kW chacun. Ces parois de cuissons au fil du temps occupent une place importante dans le monde du snack. Ce dernier est constitué d'acier inoxydable de haute qualité. L'opération de cuisson directe est très simple. Sous chaque changeur de gaz se trouve un tiroir de récupération des graisses. Ils ne peuvent être seulement retirés que si le robinet de graisse est fermé afin que le refroidissement de la friture se fait en toute sécurité. Les structures sont parfaitement mis en œuvre. Sous le réservoir à Pomme de Terre se trouve l'extraction de bord. Comme option, nous pouvons fournir le paroi de cuisson sur gaz propane. Le paroi de cuisson peut être également adaptée pour dans un camion snack. Il est idéal pour une utilisation lors d'événements très fréquentés vue sa grande capacité.



	7013.0255
	1490x975x1552
	3x 18 kW
	Ø 380
	✓
	350
	€ On request 

ELECTRIC COUNTER FRYER









 ELEKTRISCHE TAFELFRITEUSE









 ELEKTRO TISCHFRITEUSE









 ELECTRIC COUNTER FRYER









 FRITEUSE POSABLE ÉLECTRIQUE



















	7455.1003
	290x440x290
	230 V / 3 kW
	1x6
	X
	7
	€ 159,- 

	7455.1008
	590x440x290
	2x 230 V / 2x 3,3 kW
	2x6
	X
	11
	€ 280,- 





	7455.1000
	310x505x355
	230 V / 3,3 kW
	1x8
	✓
	9
	€ 243,- 

	7455.1005
	630x505x355
	2x 230 V / 2x 3,3 kW
	2x8
	✓
	14,5
	€ 428,- 









	7455.1006
	340x560x380
	400 V / 5 kW
	1x10
	✓
	10
	€ 352,- 

	7455.1007
	690x560x380
	2x 400 V / 2x 5 kW
	2x10
	✓
	17
	€ 489,- 





ELECTRIC COUNTER FRYER

-  ELEKTRISCHE TAFELFRITEUSE
-  ELEKTRO TISCHFRITEUSE
-  ELECTRIC COUNTER FRYER
-  FRITEUSE POSABLE ÉLECTRIQUE











	7471.1000
	 540x540x370
	 400 V / 9 kW
	 16
	 +50 / +190
	 35
 € 740,- 	

ELECTRIC COUNTER FRYER







-  ELEKTRISCHE TAFELFRITEUSE
-  ELEKTRO TISCHFRITEUSE
-  ELECTRIC COUNTER FRYER
-  FRITEUSE POSABLE ÉLECTRIQUE



	7471.1002
	 670x650x370
	 400 V / 15 kW
	 30
	 +50 / +190
	 50
 € 1.130,- 	







BASKET

-  MAND
-  KORB
-  BASKET
-  PANIER





	7471.1010
	 > 7471.1000
	 455x245x80
	 1,5
	 € 79,- 





BASKET

-  MAND
-  KORB
-  BASKET
-  PANIER





	7471.1012
	 > 7471.1002
	 570x440x80
	 2
	 € 93,- 





DRAINING BOARDS

-  AFDRIIPPANEEL
-  KORBABLAGE
-  DRAINING BOARDS
-  ÉGOUTTOIRS





	7471.1014
	 > 7471.1000
	 4
	 € 85,- 

DRAINING BOARDS





-  AFDRIIPPANEEL
-  KORBABLAGE
-  DRAINING BOARDS
-  ÉGOUTTOIRS





	7471.1016
	 > 7471.1002
	 5
	 € 107,- 

ELECTRIC COUNTER FRYER





-  ELEKTRISCHE TAFELFRITEUSE
-  ELEKTRO TISCHFRITEUSE
-  ELECTRIC COUNTER FRYER
-  FRITEUSE POSABLE ÉLECTRIQUE









	7466.1425
	 700x580x250
	 400 V / 6,8 kW
	 21
	 31
	 € 1.865,- 

	7466.1430
	 700x580x250
	 400 V / 9 kW
	 21
	 31
	 € 1.925,- 

DRAINING BOARDS







-  AFDRIIPPANEEL
-  KORBABLAGE
-  DRAINING BOARDS
-  ÉGOUTTOIRS

	7466.1445
	 > 7466.1425 7466.1430
	 767x392
	 6
	 € 115,- 





GAS COUNTER FRYER

-  GAS TAFELFRITEUS
-  GAS TISCHFRITEUSE
-  GAS COUNTER FRYER
-  FRITEUSE POSABLE GAS



	7466.1435
	 700x580x250
	 12 kW
	 18
	 48
	 € 2.385,- 







DRAINING BOARDS

-  AFDRIIPPANEEL
-  KORBABLAGE
-  DRAINING BOARDS
-  ÉGOUTTOIRS

	7466.1442
	 > 7466.1435
	 645x350
	 5
	 € 115,- 





FRYER

-  FRITEUSE
-  FRITEUSE
-  FRYER
-  FRITEUSE

7455.0975	
	400x800x1180
	27 kW
	21
	0 / +195
	73
	€ 1.135,- 







BASKET FRYER

-  FRITUURMAND
-  KORB FRITEUSE
-  BASKET FRYER
-  PANIER FRITEUSE

7020.1015	
	€ 64,- 

FRYER CLEANER

-  FRITUURREINIGER
-  REINIGUNGSMITTEL FRITEUSE
-  FRYER CLEANER
-  NETTOYANT FRITEUSE





7020.1020	
	€ 116,- 

JOINT

-  KOPPELSTRIP
-  VERBINDUNG
-  JOINT
-  CONNEXION

7020.1025	
	€ 49,- 



END JOINT LEFT

-  EINDSTRIP LINKS
-  ENDE VERBINDUNG LINKS
-  END JOINT LEFT
-  CONNEXION BOUT GAUCHE





7020.1035	
	€ 47,- 

HEAT SHIELD

-  HITTESCHILD
-  HITZESCHILD
-  HEAT SHIELD
-  BOUCLIER DE CHALEUR





7020.1045	
	€ 60,- 

SNACK CONTAINER

-  UITLEKBAKJE SNACK
-  BEHÄLTER FÜR SNACK
-  SNACK CONTAINER
-  CONTAINER À SNACK

7020.1030	
	€ 90,- 

END JOINT RIGHT

-  EINDSTRIP RECHTS
-  ENDE VERBINDUNG RECHTS
-  END JOINT RIGHT
-  CONNEXION BOUT DROITE

7020.1040	
	€ 47,- 

Cooking range

Drop-in

Ovens

Kitchen equipment

Refrigeration

Dishwashers

Neutral

Faucets

Ventilation





Pizzeria

Bakery

ELECTRIC FRYER

-  ELEKTRISCHE FRITEUSE
-  ELEKTRO FRITEUSE
-  ELECTRIC FRYER
-  FRITEUSE ÉLECTRIQUES



7455.0985											
	<table border="1"> <tr><td>H</td><td>695x530x970</td></tr> <tr><td>⚡</td><td>230 V / 2x 3,3 kW</td></tr> <tr><td>📏</td><td>2x 9</td></tr> <tr><td>🏠</td><td>34</td></tr> <tr><td>€</td><td>869,- </td></tr> </table>	H	695x530x970	⚡	230 V / 2x 3,3 kW	📏	2x 9	🏠	34	€	869,- 
H	695x530x970										
⚡	230 V / 2x 3,3 kW										
📏	2x 9										
🏠	34										
€	869,- 										





ELECTRIC FRYER

-  ELEKTRISCHE FRITEUSE
-  ELEKTRO FRITEUSE
-  ELECTRIC FRYER
-  FRITEUSE ÉLECTRIQUES



7455.0990											
	<table border="1"> <tr><td>H</td><td>760x590x970</td></tr> <tr><td>⚡</td><td>400 V / 2x 5 kW</td></tr> <tr><td>📏</td><td>2x 13</td></tr> <tr><td>🏠</td><td>38</td></tr> <tr><td>€</td><td>989,- </td></tr> </table>	H	760x590x970	⚡	400 V / 2x 5 kW	📏	2x 13	🏠	38	€	989,- 
H	760x590x970										
⚡	400 V / 2x 5 kW										
📏	2x 13										
🏠	38										
€	989,- 										





BASE 900 STOCK POT STOVE GAS

-  BASE 900 HOKKER GAS
-  BASE 900 HOKKER GAS
-  BASE 900 STOCK POT STOVE GAS
-  BASE 900 HOKKER GAS





7478.1500									
	<table border="1"> <tr><td>H</td><td>600x700x450</td></tr> <tr><td>🔥</td><td>18 kW</td></tr> <tr><td>🏠</td><td>83</td></tr> <tr><td>€</td><td>954,- </td></tr> </table>	H	600x700x450	🔥	18 kW	🏠	83	€	954,- 
H	600x700x450								
🔥	18 kW								
🏠	83								
€	954,- 								





BASE 900 STOCK POT STOVE ELECTRIC

-  BASE 900 HOKKER ELEKTRISCH
-  BASE 900 HOKKER ELEKTRO
-  BASE 900 STOCK POT STOVE ELECTRIC
-  BASE 900 HOKKER ÉLECTRIQUE



7478.1505									
	<table border="1"> <tr><td>H</td><td>600x500x450</td></tr> <tr><td>⚡</td><td>400 V / 4 kW</td></tr> <tr><td>🏠</td><td>28</td></tr> <tr><td>€</td><td>840,- </td></tr> </table>	H	600x500x450	⚡	400 V / 4 kW	🏠	28	€	840,- 
H	600x500x450								
⚡	400 V / 4 kW								
🏠	28								
€	840,- 								

GAS RANGE 6 BURNERS WITH GAS OVEN

-  GASFORNUIS 6 BRANDERS MET GASOVEN
-  GASHERD 6 BRENNERS MIT GASBACKOFEN
-  GAS RANGE 6 BURNERS WITH GAS OVEN
-  CUISINIÈRE À GAS 6 BRÛLEURS AVEC FOUR À GAZ



7455.0970															
	<table border="1"> <tr><td>H</td><td>918x800x1480</td></tr> <tr><td>🔥</td><td>6x 7,7 kW</td></tr> <tr><td>🔥</td><td>6 kW</td></tr> <tr><td>📏</td><td>664x590x378</td></tr> <tr><td>🏠</td><td>1/1 GN</td></tr> <tr><td>🏠</td><td>110</td></tr> <tr><td>€</td><td>2.119,- </td></tr> </table>	H	918x800x1480	🔥	6x 7,7 kW	🔥	6 kW	📏	664x590x378	🏠	1/1 GN	🏠	110	€	2.119,- 
H	918x800x1480														
🔥	6x 7,7 kW														
🔥	6 kW														
📏	664x590x378														
🏠	1/1 GN														
🏠	110														
€	2.119,- 														

BBQ-GRILL

-  BBQ-GRIL
-  BBQ
-  BBQ-GRILL
-  BBQ







7020.0250											
	<table border="1"> <tr><td>H</td><td>645x525x310</td></tr> <tr><td>🔥</td><td>10 kW</td></tr> <tr><td>📏</td><td>590x480</td></tr> <tr><td>🏠</td><td>12</td></tr> <tr><td>€</td><td>210,- </td></tr> </table>	H	645x525x310	🔥	10 kW	📏	590x480	🏠	12	€	210,- 
H	645x525x310										
🔥	10 kW										
📏	590x480										
🏠	12										
€	210,- 										

7020.0255											
	<table border="1"> <tr><td>H</td><td>700x560x805</td></tr> <tr><td>🔥</td><td>10 kW</td></tr> <tr><td>📏</td><td>590x470</td></tr> <tr><td>🏠</td><td>14</td></tr> <tr><td>€</td><td>225,- </td></tr> </table>	H	700x560x805	🔥	10 kW	📏	590x470	🏠	14	€	225,- 
H	700x560x805										
🔥	10 kW										
📏	590x470										
🏠	14										
€	225,- 										

Cooking range
Drop-in
Ovens
Kitchen equipment
Refrigeration
Dishwashers
Neutral
Faucets
Ventilation
Pizzeria
Bakery





INDUCTION COOKING TOP

-  INDUCTIE KOOKPLAAT
-  INDUKTION PLATTE
-  INDUCTION COOKING TOP
-  PLAQUE INDUCTION



















7020.0130													
	<table border="1"> <tr><td></td><td>340x440x117</td></tr> <tr><td></td><td>120-280</td></tr> <tr><td></td><td>230 V / 0.5-3.5 kW</td></tr> <tr><td></td><td>+60 / +240</td></tr> <tr><td></td><td>15</td></tr> <tr><td>€</td><td>210,- </td></tr> </table>		340x440x117		120-280		230 V / 0.5-3.5 kW		+60 / +240		15	€	210,- 
	340x440x117												
	120-280												
	230 V / 0.5-3.5 kW												
	+60 / +240												
	15												
€	210,- 												

INDUCTION WOK COOKING TOP

-  INDUCTIE WOKPLAAT
-  INDUKTION WOKPLATTE
-  INDUCTION WOK COOKING TOP
-  WOK PLAQUE INDUCTION













7020.0135											
	<table border="1"> <tr><td></td><td>340x440x117</td></tr> <tr><td></td><td>230 V / 0.5-3.5 kW</td></tr> <tr><td></td><td>+60 / +240</td></tr> <tr><td></td><td>15</td></tr> <tr><td>€</td><td>245,- </td></tr> </table>		340x440x117		230 V / 0.5-3.5 kW		+60 / +240		15	€	245,- 
	340x440x117										
	230 V / 0.5-3.5 kW										
	+60 / +240										
	15										
€	245,- 										

PAN FOR WOK

-  WOKPAN
-  PFANNE FÜR WOK
-  PAN FOR WOK
-  MARMITE POUR WOK



7020.0140							
	<table border="1"> <tr><td></td><td>625x360x210</td></tr> <tr><td></td><td>3</td></tr> <tr><td>€</td><td>112,- </td></tr> </table>		625x360x210		3	€	112,- 
	625x360x210						
	3						
€	112,- 						

CONTACT GRILL

-  CONTACT GRILL
-  KONTAKTGRILL
-  CONTACT GRILL
-  GRIL DE CONTACT





















7455.0450															
	<table border="1"> <tr><td></td><td>320x410x190</td></tr> <tr><td></td><td>✓</td></tr> <tr><td></td><td>214x214</td></tr> <tr><td></td><td>+50 / +300</td></tr> <tr><td></td><td>230 V / 1,8 kW</td></tr> <tr><td></td><td>13,5</td></tr> <tr><td>€</td><td>214,- </td></tr> </table>		320x410x190		✓		214x214		+50 / +300		230 V / 1,8 kW		13,5	€	214,- 
	320x410x190														
	✓														
	214x214														
	+50 / +300														
	230 V / 1,8 kW														
	13,5														
€	214,- 														



CONTACT GRILL PANINI

-  CONTACT GRILL PANINI
-  KONTAKTGRILL PANINI
-  CONTACT GRILL PANINI
-  GRIL DE CONTACT PANINI

























7455.0455															
	<table border="1"> <tr><td></td><td>440x410x190</td></tr> <tr><td></td><td>✓</td></tr> <tr><td></td><td>340x220</td></tr> <tr><td></td><td>+50 / +300</td></tr> <tr><td></td><td>230 V / 2,2 kW</td></tr> <tr><td></td><td>20</td></tr> <tr><td>€</td><td>253,- </td></tr> </table>		440x410x190		✓		340x220		+50 / +300		230 V / 2,2 kW		20	€	253,- 
	440x410x190														
	✓														
	340x220														
	+50 / +300														
	230 V / 2,2 kW														
	20														
€	253,- 														

CONTACT GRILL

-  CONTACT GRILL
-  KONTAKTGRILL
-  CONTACT GRILL
-  GRIL DE CONTACT



7455.0460															
	<table border="1"> <tr><td></td><td>580x410x190</td></tr> <tr><td></td><td>✓</td></tr> <tr><td></td><td>2 x 214x214</td></tr> <tr><td></td><td>+50 / +300</td></tr> <tr><td></td><td>2x 230 V / 3,6 kW</td></tr> <tr><td></td><td>26</td></tr> <tr><td>€</td><td>391,- </td></tr> </table>		580x410x190		✓		2 x 214x214		+50 / +300		2x 230 V / 3,6 kW		26	€	391,- 
	580x410x190														
	✓														
	2 x 214x214														
	+50 / +300														
	2x 230 V / 3,6 kW														
	26														
€	391,- 														

WATER GRILL





-  WATERGRIL
-  WASSERGRILL
-  WATER GRILL
-  GRILL D'EAU







7472.0050													
	<table border="1"> <tr><td></td><td>490x500x210</td></tr> <tr><td></td><td>✓</td></tr> <tr><td></td><td>410x340</td></tr> <tr><td></td><td>400 V / 5 kW</td></tr> <tr><td></td><td>17</td></tr> <tr><td>€</td><td>853,- </td></tr> </table>		490x500x210		✓		410x340		400 V / 5 kW		17	€	853,- 
	490x500x210												
	✓												
	410x340												
	400 V / 5 kW												
	17												
€	853,- 												

Cooking range
Drop-in
Ovens
Kitchen equipment
Refrigeration
Dishwashers
Neutral
Faucets
Ventilation
Pizzeria
Bakery



ELECTRIC FRY TOP

-  ELEKTRISCHE BAKPLAAT
-  ELEKTRO GRILLPLATTE
-  ELECTRIC FRY TOP
-  PLAQUE GRIL ÉLECTRIQUE





7455.1075	
	550x470x230
	230 V / 3 kW
	✓
	21
€	198,- 

GAS FRY TOP

-  GAS BAKPLAAT
-  GAS GRILLPLATTE
-  GAS FRY TOP
-  PLAQUE GRIL GAS







7457.0005	
	550x515x240
	5 kW
	✓
	23
€	595,- 













ELECTRIC FRY TOP

7455.1080	
	730x510x230
	230 V / 3,5 kW
	✓
	31,5
€	247,- 





ELECTRIC FRY TOP

-  ELEKTRISCHE BAKPLAAT
-  ELEKTRO GRILLPLATTE
-  ELECTRIC FRY TOP
-  PLAQUES GRIL ÉLECTRIQUE



			SURFACE		€	
7455.1050	500x520x310	230 V / 3kW		31,5	312,-	
7455.1055	500x520x310	230 V / 3 kW		31,5	480,-	
7455.1060	600x520x310	400 V / 5 kW		34,5	425,-	
7455.1065	600x520x310	400 V / 5 kW		34,5	480,-	





CHICKEN ROTISSERIES ELECTRIC

-  KIPPENGRIL ELEKTRISCH
-  HÄHNCHENGRILL ELEKTRO
-  CHICKEN ROTISSERIES ELECTRIC
-  RÔTISSOIRES À ÉLECTRIQUE

















7472.0005	
	940x590x780
	400 V / 5,4 kW
	4x
	79
€	2.795,- 

CHICKEN ROTISSERIES GAS





-  KIPPENGRIL GAS
-  HÄHNCHENGRILL GAS
-  CHICKEN ROTISSERIES GAS
-  RÔTISSOIRES À GAS









7472.0020	
	1320x460x680
	230 V / 0,1 kW
	6 kW
	10x
	2x
	65
€	1.629,- 







7472.0025	
	1320x460x880
	230 V / 0,1 kW
	12 kW
	15x
	3x
	85
€	2.075,- 

CHICKEN ROTISSERIES ELECTRIC

-  KIPPENGRIL ELEKTRISCH
-  HÄHNCHENGRILL ELEKTRO
-  CHICKEN ROTISSERIES ELECTRIC
-  RÔTISSOIRES À ÉLECTRIQUE





7472.0030	
	1320x460x660
	400 V / 5,2 kW
	10x
	2x
	65
€	1.495,- 

7472.0035	
	1320x460x855
	400 V / 7,8 kW
	15x
	3x
	85
€	2.025,- 

7472.0040	
	1020x640x830
	400 V / 5,4 kW
	3x
	85
€	1.995,- 

SPIT

-  SPIT
-  SPIEB
-  SPIT
-  BROCHE





7472.0015	
	2
€	70,- 

BASKET





-  MAND
-  KORB
-  BASKET
-  PANIER

7472.0010	
	2
€	108,- 





GYROS GRILL GAS MOTOR ON TOP

-  GYROS GRILL GAS MOTOR BOVEN
-  GYROS GRILL GAS MOTORPOSITION OBEN
-  GYROS GRILL GAS MOTOR ON TOP
-  GYROS GRIL DE GAZ MOTEUR AU-DESSUS







7481.0005	
	550x680x920
	8,4 kW
	29
	€ 1.050,- 





GYROS GRILL GAS MOTOR ON BOTTOM

-  GYROS GRILL GAS MOTOR ONDER
-  GYROS GRILL GAS MOTORPOSITION UNTEN
-  GYROS GRILL GAS MOTOR ON BOTTOM
-  GYROS GRIL DE GAZ MOTEUR AU-DESSOUS







7481.0015	
	620x760x840
	8,4 kW
	37
	€ 1.280,- 







7481.0010	
	550x740x1120
	11,2 kW
	32
	€ 1.125,- 







7481.0020	
	620x760x1040
	11,2 kW
	42
	€ 1.405,- 





GYROS GRILL ELECTRIC MOTOR ON TOP

-  GYROS GRILL ELEKTRISCH MOTOR BOVEN
-  GYROS GRILL ELEKTRO MOTORPOSITION OBEN
-  GYROS GRILL ELECTRIC MOTOR ON TOP
-  GYROS GRIL ELECTRIQUE MOTEUR AU-DESSUS







7481.0025	
	550x740x920
	400 V / 5,7 kW
	32
	€ 1.323,- 







7481.0030	
	550x740x1120
	4000 V / 7,6 kW
	35
	€ 1.448,- 





GYROS GRILL ELECTRIC MOTOR ON BOTTOM

-  GYROS GRILL ELEKTRISCH MOTOR ONDER
-  GYROS GRILL ELEKTRO MOTORPOSITION UNTEN
-  GYROS GRILL ELECTRIC MOTOR ON BOTTOM
-  GYROS GRIL ELECTRIQUE MOTEUR AU-DESSOUS







7481.0035	
	620x760x840
	400 V / 5,7 kW
	40
	€ 1.398,- 



7481.0040	
	620x760x1040
	4000 V / 7,6 kW
	45
	€ 1.523,- 

DONER SLICER ELECTRIC

-  DONERMES ELECTRISCH
-  DÖNERSCHNEIDER ELEKTRO
-  DONER SLICER ELECTRIC
-  COUPEUSE DONER ÉLECTRIQUE





	7455.0070
	 230x185x280
	 230 V / 0,08 kW
	 100
	 0-8
	 1,25
	 € 189,- 

SALAMANDER







-  SALAMANDER
-  SALAMANDER
-  SALAMANDER
-  SALAMANDRE











SALAMANDER TOASTER







-  SALAMANDER TOASTER
-  SALAMANDER TOASTER
-  SALAMANDER TOASTER
-  SALAMANDRE TOASTER







	7455.1600
	 450x480x500
	 230 V / 2,8 kW
	 440x320
	 45
	 € 628,- 







	7455.1645
	 490x250x280
	 230 V / 2,4 kW
	 9
 € 231,- 	

	7455.1605
	 600x480x520
	 230 V / 3,5 kW
	 590x330
	 65
	 € 693,- 





	7455.1650
	 490x250x380
	 230 V / 3,6 kW
	 11
	 € 289,- 







GIORIK SALAMANDER TOUCH

-  GIORIK SALAMANDER TOUCH
-  GIORIK SALAMANDER TOUCH
-  GIORIK SALAMANDER TOUCH
-  GIORIK SALAMANDER ÉCRAN TACTILE







	7466.1495
	 570x530x500
	 400 V / 4,5 kW
	 550 x 370
	 65
	 € 3.135,- 



GIORIK SALAMANDER

-  GIORIK SALAMANDER
-  GIORIK SALAMANDER
-  GIORIK SALAMANDER
-  GIORIK SALAMANDRE

	7466.1480
	 400x450x510
	 230 V / 3 kW
	 340 x 310
	 43
	 € 1.825,- 

	7466.1500
	 735x530x500
	 400 V / 5,3 kW
	 710 x 370
	 80,5
	 € 3.750,- 

	7466.1485
	 570x530x500
	 400 V / 4,5 kW
	 550 x 370
	 65
	 € 2.640,- 

	7466.1490
	 735x530x500
	 400 V / 5,3 kW
	 710 x 370
	 80,5
	 € 3.120,- 



Cooking range

Drop-in

Ovens

Kitchen equipment

Refrigeration

Dishwashers

Neutral

Faucets

Ventilation







Pizzeria







Bakery

CREPE MAKER

-  CREPE MAKER
-  CREPE GERÄTE
-  CREPE MAKER
-  CREPIÈRE



	7455.1610
	450x490x235
	400
	230 V / 3 kW
	20
	€ 331,- 

	7455.1615
	860x490x235
	400
	230 V / 6 kW
	30
	€ 535,- 

WAFFLE MAKER

-  WAFELIJZER
-  WAFFLEISEN
-  WAFFLE MAKER
-  MACHINE A GAUFRE













	7455.1620
	300x450x250
	230 V / 2 kW
	100 x 170
	20
	€ 278,- 

TOASTER

-  BROODROOSTER
-  TOASTER
-  TOASTER
-  GRILLE-PAIN



	7455.1635
	290x260x220
	230 V / 1,8 kW
	slices 4
	5
	€ 151,- 

	7455.1640
	420x260x220
	230 V / 2,5 kW
	slices 6
	7
	€ 192,- 

PASTA COOKER

-  PASTAKOKER
-  NUDELKOCHER
-  PASTA COOKER
-  CUISEURS POUR PATES











	7455.1655
	400x680x370
	400 V / 4,5 kW
	20
	€ 799,- 

MEAT CUTTER









-  VLEESSNIJMACHINE
-  FLEISCH FRÄSER
-  MEAT CUTTER
-  COUPEUSE DE VIANDE











							
7013.0082	500x520x310	230 V / 0,12 kW	220	12	10	499,-	
7013.0085	500x520x310	230 V / 0,18 kW	250	12	15	599,-	
7013.0087	600x520x310	230 V / 0,25 kW	300	15	25	950,-	





MEATGRINDER

-  GEHAKTMOLEN
-  FLEISCHWOLF
-  MEATGRINDER
-  HACHOIR

	7455.0085
	432x261x484
	230 V / 0,55 kW
	100
	170
	24
	€ 640,- 

	7455.0090
	519x261x495
	230 V / 0,9 kW
	200
	170
	32
	€ 845,- 





VEGETABLE CUTTER WITH 5 KNIVES

-  GROENTESNIJDER MET 5 MESSEN
-  GEMÜSE FRÄSER MIT 5 MESSER
-  VEGETABLE CUTTER WITH 5 KNIVES
-  COUPEUSE DE LÉGUME AVEC 5 COUTEAUX













	7455.0080
	570x230x510
	230 V / 0,55 kW
	26
	€ 899,- 

TOP SHOWCASE

-  WARMHOUDVITRINE
-  WÄRMETHEKEN
-  TOP SHOWCASE
-  BUFFET VITRINE CHAUFFANTE



	7455.1125
	1039x365x330
	230 V / 1,5 kW
GN	5x 1/3 GN
	13
€	338,- 

	7455.1130
	1339x365x330
	230 V / 1,5 kW
GN	7x 1/3 GN
	16
€	419,- 

SOUP KETTLE

-  SOEPKETEL
-  SUPPENKOCHER
-  SOUP KETTLE
-  MARMITE À SOUPE













	7476.0005
	Ø360x400
	230 V / 0.4 kW
	10
	6
€	75,- 

BAIN-MARIE





-  BAIN MARIE
-  BAIN-MARIE
-  BAIN-MARIE
-  BAIN-MARIE







	7476.0010
	538x336x243
	230 V / 1,2 kW
GN	1x 1/1
	9
€	98,- 

	7476.0015
	538x336x243
	230 V / 1,2 kW
GN	1x 1/1
	9
€	120,- 





BLENDER

-  BLENDER
-  BLENDER
-  BLENDER
-  MIXER



	7013.2515
	210x230x520
	230 V / 1,5 kW
	5
€	258,- 

GRANITA MACHINE

-  SLUSH PUPPIE AUTOMAAT
-  SLUSH PUPPIE AUTOMAT
-  GRANITA MACHINE
-  AUTOMATE DE SLUSH PUPPIE



	7470.0005
	200x480x800
	230 V / 0,53 kW
	1 x 10
	30
€	1.255,- 







	7470.0010
	400x480x800
	230 V / 0,85 kW
	2 x 10
	55
€	2.236,- 







	7470.0015
	600x480x800
	230 V / 1,1 kW
	3 x 10
	73
€	2.834,- 





CITRUSPERS SEMI-PROFESIONEEL

-  CITRUSPERS SEMI-PROFESIONEEL
-  ZITRUSPRESSE SEMI-PROFESIONELL
-  CITRUS PRESS SEMI-PROFESSIONAL
-  PRESSE FRUITS SEMI-PROFESIONEL









	7013.2500
	218x308x354
	230 V / 0.18 kW
Rpm	1300
	5
€	129,- 







DRINK DISPENSER

-  DRANKEN DISPENSER
-  GETRÄNKE DISPENSER
-  DRINK DISPENSER
-  DISTRIBUTEUR DE BOISSONS





	7470.0020
	300x300x600
	230 V / 0,68 kW
	2 x 6
	23
€	749,- 



	7470.0025
	450x300x600
	230 V / 0,9 kW
	3 x 6
	30
€	1.019,- 

CITRUSPERS

-  CITRUSPERS
-  ZITRUSPRESSE
-  CITRUS PRESS
-  PRESSE FRUITS











	7013.2505
	218x308x430
	230 V / 0.18 kW
Rpm	1800
	5
€	157,- 

POPCORN MACHINE





-  POPCORN MACHINE
-  POPCORN-GERÄT
-  POPCORN MACHINE
-  APPAREIL POPCORN



	7455.0810	
	 H	560x417x770
		230 V / 1,35 kW
	 KG	23
	€	338,- 

	7455.0815	
	 H	560x417x1560
		230 V / 1,35 kW
	 KG	39
	€	559,- 

CANDY FLOSS MACHINE

-  SUIKERSPIN MACHINE
-  ZUCKERWATTE-MASCHINE
-  CANDY FLOSS MACHINE
-  MACHINE BARBE À PAPA



	7455.0800	
	 H	740x740x530
	 Ø	710
		230 V / 0,95 kW
	 KG	20
€	505,- 	





	7455.0805	
	 H	540x540x530
	 Ø	500
		230 V / 0,95 kW
	 KG	15
€	495,- 	







ESPRESSO MACHINE

-  ESPRESSO MACHINE
-  ESPRESSOMASCHINE
-  ESPRESSO MACHINE
-  MACHINE D'ESPRESSO



	7047.0015	
	 H	677x523x580
		230 V/4,5 kW
	 KG	60
	€	3.500,- 







	7047.0020	
	 H	967x523x580
		400 V/6 kW
	 KG	80
	€	5.250,- 





ESPRESSO MACHINE

-  ESPRESSO MACHINE
-  ESPRESSOMASCHINE
-  ESPRESSO MACHINE
-  MACHINE D'ESPRESSO







	7047.0025	
	 H	650x480x530
		230 V/2,7 kW
	 KG	48
	€	2.195,- 











	7047.0030	
	 H	650x480x530
		230 V/2,7 kW
	 KG	51
	€	1.950,- 







COFFEE MACHINE

-  KOFFIEMACHINE
-  KAFFEEMASCHINE
-  COFFEE MACHINE
-  MACHINE DE CAFÉ











	7020.0008			
	195x360x425		1,8	
	230 V/2,1 kW		1,8 / 5 MIN	
	7,9			
	€ 259,-			

COFFEE MACHINE

-  KOFFIEMACHINE
-  KAFFEEMASCHINE
-  COFFEE MACHINE
-  MACHINE DE CAFÉ











	7020.0009			
	210x350x425		1,8	
	230 V/2,1 kW		1,8 / 5 MIN	
	9			
	€ 249,-			





COFFEE MACHINE WATER CONNECTION

-  KOFFIEMACHINE WATERAANSLUITING
-  KAFFEEMASCHINEN WASSERANSCHLUSS
-  COFFEE MACHINE WATER CONNECTION
-  MACHINE DE CAFÉ CONNEXION D'EAU











	7020.0010			
	210x350x425		1,8	
	230 V/2,1 kW		1,8 / 5 MIN	
	9			
	€ 289,-			





COFFEE MACHINE

-  KOFFIEMACHINE
-  KAFFEEMASCHINE
-  COFFEE MACHINE
-  MACHINE DE CAFÉ



	7020.0011			
	195x360x445		1,75	
	230 V/1,9 kW		1,8 / 5 MIN	
	7,2			
	€ 236,-			

COFFEE PERCOLATOR





-  KOFFIE PERCOLATOR
-  KAFFEE PERCOLATOR
-  COFFEE PERCOLATOR
-  PERCOLATEUR DE CAFÉ

	7020.0012	
	6,5	
	40 / 25 MIN	
	230 V/1,5 kW	
	4,2	
	€ 116,-	

	7020.0014	
	15	
	100 / 60 MIN	
	230 V/1,5 kW	
	6,2	
	€ 181,-	







GREASE TRAP SS

-  VETAFSCHEIDER RVS
-  FETTABSCHIEDER EDEKSTAHL
-  GREASE TRAP SS
-  SÉPARATEUR DE GRAISSE INOX









	7020.0210	
	385x385x290	
	36 Ltr/min	
CAP	9 KG	
	50	
	15	
	€ 320,-	





GREASE TRAP

-  VETAFSCHEIDER
-  FETTABSCHIEDER
-  GREASE TRAP
-  SÉPARATEUR DE GRAISSE



	7020.0215	
	490x330x350	
	27 Ltr/min	
CAP	7 KG	
	50	
	21	
	€ 259,-	





HOSE FOR GREASE TRAP

-  VERBINDINGSSTUK VOOR VETAFSCHEIDER
-  SCHLAUCH FÜR FETTABSCHIEDER
-  HOSE FOR GREASE TRAP
-  TUYAU DE SEPERATEUR DE GRAISSE



	7020.0220	
	2x	
	50	
	€ 10,-	





PLATE RACK WALL MODEL

-  BORDENREK WANDMODEL
-  TELLER REGAL WANDMODELL
-  PLATE RACK WALL MODEL
-  PORTE-ASSIETTES-DRESSÉES MURALE



	L	H	∅	KG	€
7036.0011	70	600	6	1.2	129,-
7036.0013	70	800	9	1.8	164,-
7036.0015	70	1000	12	2.2	199,-
7036.0027	70	1410	18	3.1	245,-
7036.0029	70	1620	21	3.3	292,-

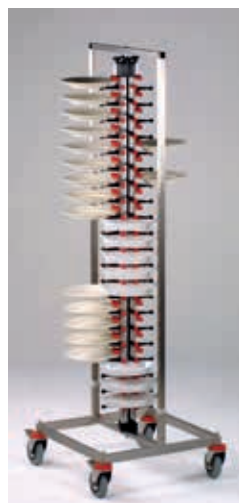

PLATE RACK TROLLEY

-  BORDENREK TROLLEY
-  TELLER REGAL TROLLEY
-  PLATE RACK TROLLEY
-  PORTE-ASSIETTES-DRESSÉES TROLLEY



7036.0035	
	
H	600x600x 1860
∅	84x
KG	25
€	1.029,-



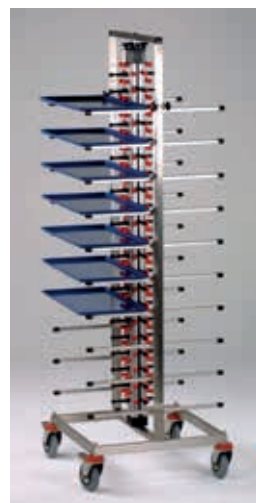

SERVING TRAY BRACKET

-  DIENBLADENREK
-  TABLETTS TRÄGER
-  SERVING TRAY BRACKET
-  PLATEAU SUPPORT



7036.0040	
	
>	7036.0035
∅	20x
KG	14
€	327,-

COVER

-  HOES BORDENREK TROLLEY
-  SCHUTZHAUBEN TELLER REGAL TROLLEY ZUSAMMENKLAPBAR
-  COVER PLATE RACK TROLLEY COLLAPSIBLE
-  CAPUCHON CHARIOT PORTE-ASSIETTES-DRESSÉES ESCAMOTABLE







7036.0060	
	
>	7036.0035
KG	3,5
€	269,-





PLATE RACK TROLLEY COLLAPSIBLE

-  BORDENREK TROLLEY INKLAPBAAR
-  TELLER REGAL TROLLEY ZUSAMMENKLAPBAR
-  PLATE RACK TROLLEY COLLAPSIBLE
-  CHARIOT PORTE-ASSIETTES-DRESSÉES ESCAMOTABLE



	H	∅	KG	€
7036.0045	480x480x1270	48	16	771,-
7036.0050	480x480x1490	60	19	888,-
7036.0055	480x480x1890	84	24	1.064,-

COVER

-  HOES BORDENREK TROLLEY INKLAPBAAR
-  SCHUTZHAUBEN FÜR TELLER REGAL TROLLEY ZUSAMMENKLAPBAR
-  COVER FOR PLATE RACK TROLLEY COLLAPSIBLE
-  CAPUCHON POUR CHARIOT PORTE-ASSIETTES-DRESSÉES ESCAMOTABLE

	>	KG	€
7036.0075	7036.0045	3	222,-
7036.0070	7036.0050	3,5	234,-
7036.0065	7036.0055	4	269,-









Koeling
Kühlung
Refrigeration
Réfrigération

REFRIGERATOR WHITE

-  KOELKAST WIT
-  KÜHLSCHRANK WEIß
-  REFRIGERATOR WHITE
-  RÉFRIGÉRATEUR BLANC







FREEZER WHITE

-  VRIESKAST WIT
-  TIEFKÜHLSCHRANK WEIß
-  FREEZER WHITE
-  CONGÉLATEUR BLANC







REFRIGERATOR SS

-  KOELKAST RVS
-  KÜHLSCHRANK EDELSTAHL
-  REFRIGERATOR SS
-  RÉFRIGÉRATEUR EN ACIER INOX



FREEZER SS

-  VRIESKAST RVS
-  TIEFKÜHLSCHRANK EDELSTAHL
-  FREEZER SS
-  CONGÉLATEUR EN ACIER INOX



	7450.0556		600x585x1850		510x485x1620
		350		4x	
		230V / 0,185kW		✓	
		0 / +8°C		✓	
		69		✓	
	€	740,-			✓

	7450.0571		600x585x1850		510x485x1620
		340		6x	
		230V / 0,210kW		✓	
		< -18 °C		✓	
		74		✓	
	€	822,-			X

	7450.0561		775x650x1885		665x580x1660
		570	GN	4x 2/1GN	
		230V / 0,2kW		✓	
		0 / +8°C		✓	
		90		✓	
	€	955,-			✓

	7450.0576		775x650x1885		665x580x1660
		555		6x	
		230V / 0,35kW		✓	
		< -18 °C		✓	
		94		✓	
	€	1.030,-			X

ACCESSORIES

	7451.0015		502x440	€	17,-	
	>	7450.0556				
	7451.0016		650x535	€	18,-	
	>	7450.0561	GN 2/1GN			
	7451.0021	13x		€	175,-	
	>					

	7451.0011	€	49,-	
	>			
	7451.0045	€	39,-	
	>			

	7450.0550		600x585x850		510x485x620
		130		3x	
		230V / 0,15kW		✓	
		0 / +8°C		✓	
		44		✓	
	€	545,-			✓

	7450.0565		600x585x850		510x485x620
		120		3x	
		230V / 0,15kW		✓	
		< -18 °C		✓	
		44		✓	
	€	572,-			X

	7450.0555		600x585x1850		510x485x1620
		350		4x	
		230V / 0,185kW		✓	
		0 / +8°C		✓	
		69		✓	
	€	838,-			✓

	7450.0570		600x585x1850		510x485x1620
		340		6x	
		230V / 0,21kW		✓	
		< -18 °C		✓	
		74		✓	
	€	928,-			X

	7450.0560		775x650x1885		665x580x1660
		570	GN	4x 2/1GN	
		230V / 0,2kW		✓	
		0 / +8°C		✓	
		90		✓	
	€	1.075,-			✓





	7450.0575		775x650x1885		665x580x1660
		555		6x	
		230V / 0,35kW		✓	
		< -18 °C		✓	
		94		✓	
	€	1.144,-			X

ACCESSORIES

	7451.0015		502x440	€	17,-	
	>	7450.0550-7450.0555				
	7451.0016		650x535	€	18,-	
	>	7450.0560	GN 2/1GN			
	7451.0021	13x		€	175,-	
	>					













	7451.0011	€	49,-	
	>			
	7451.0045	€	39,-	
	>			

REFRIGERATOR SS





-  KOELKAST RVS
-  KÜHLSCHRANK EDELSTAHL
-  REFRIGERATOR SS
-  RÉFRIGÉRATEUR EN ACIER INOX

GREY LABEL















	7950.3660	 680x800x2010	 560x653x1386
	600	 GN	3x 2/1GN
	230V / 0,45kW		✓
	-2 / +8°C		✓
	140		✓
€	1.240,-		R 134 A













FREEZER SS













-  VRIESKAST RVS
-  TIEFKÜHLSCHRANK EDELSTAHL
-  FREEZER SS
-  CONGÉLATEUR EN ACIER INOX

GREY LABEL









	7950.3665	 680x800x2010	 560x653x1386
	600	 GN	3x 2/1GN
	230V / 0,75kW		✓
	-18 / -25°C		✓
	130		✓
€	1.582,-		R 404 A

	7950.3650	 1340x800x2000	 1220x653x1386
	1200	 GN	6x 2/1GN
	230V / 0,45kW		✓
	-2 / +8°C		✓
	190		✓
€	1.940,-		R 134 A

	7950.3655	 1340x800x2010	 1220x653x1386
	1200	 GN	6x 2/1GN
	230V / 1kW		✓
	-18 / -25°C		✓
	190		✓
€	2.190,-		R 404 A













ACCESSORIES

	7451.0010	€ 66,-	
	7450.0501	€ 32,-	
	7450.0502	€ 22,-	
	GN 2/1GN		





REFRIGERATOR WHITE

-  KOELKAST WIT
-  KÜHLSCHRANK WEIß
-  REFRIGERATOR WHITE
-  RÉFRIGÉRATEUR BLANC



























	7450.3660	 680x800x2010	 560x653x1386
	600	 GN	3x 2/1GN
	230V / 0,45kW		✓
	-2 / +8°C		✓
	140		✓
€	1.225,-		R 134 A













FREEZER WHITE

-  VRIESKAST WIT
-  TIEFKÜHLSCHRANK WEIß
-  FREEZER WHITE
-  CONGÉLATEUR BLANC









	7450.3665	 680x800x2010	 560x653x1386
	600	 GN	3x 2/1GN
	230V / 0,75kW		✓
	-18 / -25°C		✓
	130		✓
€	1.488,-		R 404 A





	7450.3650	 1340x800x2000	 1220x653x1386
	1200	 GN	6x 2/1GN
	230V / 0,45kW		✓
	-2 / +8°C		✓
	190		✓
€	1.709,-		R 134 A

	7450.3655	 1340x800x2010	 1220x653x1386
	1200	 GN	6x 2/1GN
	230V / 1kW		✓
	-18 / -25°C		✓
	190		✓
€	1.998,-		R 404 A











ACCESSORIES

	7451.0010	€ 66,-	
	7450.0501	€ 32,-	
	7450.0502	€ 22,-	
	GN 2/1GN		





REFRIGERATOR SS

-  KOELKAST RVS
-  KÜHLSCHRANK EDELSTAHL
-  REFRIGERATOR SS
-  RÉFRIGÉRATEUR EN ACIER INOX

























	7450.0072			
		740x830x2010		624x685x1396
		650	GN	3x 2/1GN
		230V / 0,45kW		✓
		-2 / +8°C		✓
		120		✓
€	1.490,-		R R 134 A	











FREEZER SS

-  VRIESKAST RVS
-  TIEFKÜHLSCHRANK EDELSTAHL
-  FREEZER SS
-  CONGÉLATEUR EN ACIER INOX









	7450.0076			
		740x830x2010		624x685x1396
		650	GN	3x 2/1GN
		230V / 0,75kW		✓
		-18 / -25°C		✓
		130		✓
€	1.774,-		R R 404 A	





	7450.0074			
		1480x830x2010		1360x685x1390
		1410	GN	6x 2/1GN
		230V / 0,45kW		✓
		-2 / +8°C		✓
		190		✓
€	2.299,-		R R 134 A	

	7450.0078			
		1480x830x2010		1360x685x1390
		1410	GN	6x 2/1GN
		230V / 1kW		✓
		-18 / -25°C		✓
		200		✓
€	2.650,-		R R 404 A	











ACCESSORIES











	7451.0010	€	66,-	
	7450.0501	€	32,-	
	7450.0502	€	22,-	
	GN 2/1GN			

REFRIGERATOR/ FREEZER





-  KOEL/VRIESKAST
-  KÜHL/ TIEFKÜHLSCHRANK
-  REFRIGERATOR/ FREEZER
-  RÉFRIGÉRATEUR/ CONGÉLATEUR





















	7450.0715			
		740x830x2010		2x560x650x650
		2x 237	GN	4x 2/1GN
		230V / 0,58kW		✓
		-2/+8 -18/-22		✓
		150		✓
€	2.040,-		R R 134 A / R 404A	

	7450.0720			
		1480x830x2010		2x560x653x1386
		2x 507	GN	6x 2/1GN
		230V / 0,9kW		✓
		-2/+8 -18/-22		✓
		195		✓
€	3.170,-		R R 134 A / R 404A	





REFRIGERATOR SS GLASS DOOR









-  KOELKAST RVS GLASDEUR
-  KÜHLSCHRANK RFS GLASTÜR
-  REFRIGERATOR SS GLASS DOOR
-  RÉFRIGÉRATEUR EN ACIER INOX PORTE EN VERRE

	7450.0152			
		740x830x2010		624x685x1396
		597	GN	3x 2/1GN
		230V / 0,58kW		✓
		+2/+8		✓
		138		✓
€	1.860,-		R R 134 A	

	7450.0154			
		1480x830x2010		1360x685x1390
		1325	GN	6x 2/1GN
		230V / 0,53kW		✓
		+2/+8		✓
		208		✓
€	2.618,-		R R 134 A	

FREEZER SS GLASS DOOR













-  VRIESKAST RVS GLASDEUR
-  TIEFKÜHLSCHRANK RFS GLASTÜR
-  FREEZER SS GLASS DOOR
-  CONGÉLATEUR EN ACIER INOX PORTE EN VERRE

	7450.0150			
		740x830x2010		624x685x1396
		597	GN	3x 2/1GN
		230V / 0,75kW		✓
		-18/-22		✓
		153		✓
€	2.456,-		R R 404 A	

REFRIGERATOR

-  KOELKAST
-  KÜHLSCHRANK
-  REFRIGERATOR
-  RÉFRIGÉRATEUR



























	7477.0005			
	720x715x2080	R	R 134 A	
	600		3x	
	230V / 0,41kW		✓	
	0 / +10°C		X	
	120		✓	
€	1.810,-			✓













FREEZER

-  VRIESKAST
-  TIEFKÜHLSCHRANK
-  FREEZER
-  CONGÉLATEUR











	7477.0015			
	720x715x2080	R	R 404 A	
	600		3x	
	230V / 0,58kW		✓	
	-18 / -22°C		X	
	125		✓	
€	2.260,-			✓

	7477.0010			
	1440x715x2080	R	R 134 A	
	1200		6x	
	230V / 0,51kW		✓	
	0 / +10°C		X	
	192		✓	
€	2.690,-			✓

	7477.0020			
	1440x715x2080	R	R 404 A	
	1200		6x	
	230V / 0,77kW		✓	
	-18 / -22°C		X	
	197		✓	
€	3.340,-			✓

ACCESSORIES











	7477.1015	€	23,-	
	7477.1020			
	530x530	€	40,-	

	7477.1025	€	17,-	
	7477.1030	€	103,-	

REFRIGERATOR

-  KOELKAST
-  KÜHLSCHRANK
-  REFRIGERATOR
-  RÉFRIGÉRATEUR

























	7477.0100			
	720x815x2080	R	R 134 A	
	700	GN	3x 2/1 GN	
	230V / 0,41kW		✓	
	0 / +10°C		X	
	130		✓	
€	1.835,-			✓











FREEZER

-  VRIESKAST
-  TIEFKÜHLSCHRANK
-  FREEZER
-  CONGÉLATEUR











	7477.0110			
	720x815x2080	R	R 404 A	
	700	GN	3x 2/1 GN	
	230V / 0,58kW		✓	
	-18 / -22°C		X	
	135		✓	
€	2.295,-			✓

	7477.0130			
	1440x815x2080	R	R 134 A	
	1400	GN	6x 2/1 GN	
	230V / 0,51kW		✓	
	0 / +10°C		X	
	206		✓	
€	2.760,-			✓



	7477.0135			
	1440x815x2080	R	R 404 A	
	1400	GN	6x 2/1 GN	
	230V / 0,77kW		✓	
	-18 / -22°C		X	
	214		✓	
€	3.295,-			✓

ACCESSORIES

	7477.1035	€	23,-	
	7450.0502			
	GN 2/1 GN	€	20,-	





	7477.1025	€	17,-	
	7477.1030	€	103,-	

REFRIGERATOR FISH

-  KOELKAST VIS
-  KÜHLSCHRANK FISH
-  REFRIGERATOR FISH
-  RÉFRIGÉRATEUR POISSON







REFRIGERATOR MEAT

-  KOELKAST VLEES
-  KÜHLSCHRANK FLEISCH
-  REFRIGERATOR MEAT
-  RÉFRIGÉRATEUR VIANDE







REFRIGERATOR GLASS DOOR













-  KOELKAST GLASDEUR
-  KÜHLSCHRANK GLASTÜR
-  REFRIGERATOR GLASS DOOR
-  RÉFRIGÉRATEUR PORTE EN VERRE



























REFRIGERATOR LOW TEMPERATURE











-  KOELKAST DIEPTEKOELING
-  KÜHLSCHRANK TIEF TEMPERATUR
-  REFRIGERATOR LOW TEMPERATURE
-  RÉFRIGÉRATEUR BASSE TEMPÉRATURE



























	7477.0120				
	720x825x2080	R	R 134 A		
	700		6x 1/1 GN		
	230V / 0,41kW		✓		
	-2 / +10°C		X		
	143		✓		
€	2.595,-		✓		✓

	7477.0125				
	720x825x2080	R	R 134 A		
	700		2x		
	230V / 0,41kW		✓		
	-2 / +10°C		X		
	143		✓		
€	2.690,-		✓		✓







	7477.0115				
	720x825x2080	R	R 134 A		
	700		3x		
	230V / 0,41kW		✓		
	-2 / +10°C		X		
	147		✓		
€	2.240,-		✓		✓





	7477.0145				
	1440x825x2080	R	R 134 A		
	1400		6x		
	230V / 0,51kW		✓		
	-2 / +10°C		X		
	206		✓		
€	3.940,-		✓		✓

	7477.0150				
	1440x825x2080	R	R 134 A		
	1400		4x		
	230V / 0,51kW		✓		
	-2 / +10°C		X		
	229		✓		
€	3.695,-		✓		✓





	7477.0140				
	1440x825x2080	R	R 134 A		
	1400		6x		
	230V / 0,51kW		✓		
	-2 / +10°C		X		
	240		✓		
€	3.440,-		✓		✓





ACCESSORIES

	7477.1035			€ 23,-	
	7450.0502				
	GN 2/1 GN			€ 40,-	
	7477.1040				
	GN 1/1 GN			€ 33,-	

	7477.1025			€ 17,-	
	7477.1030			€ 103,-	

ACCESSORIES













	7477.1035			€ 23,-	
	7450.0502				
	GN 2/1 GN			€ 20,-	

	7477.1025			€ 17,-	
	7477.1030			€ 103,-	

REFRIGERATOR

-  KOELKAST
-  KÜHLSCHRANK
-  REFRIGERATOR
-  RÉFRIGÉRATEUR















	7450.0700			
		484x700x2010		368x580x1396
		350	GN	3x 1/1GN
	R	R 134 A		✓
		230V / 0,25kW		✓
		-2 / +8°C		✓
		110		✓
€	1.390,- 			

REFRIGERATOR 1 DOOR 3 DRAWERS

-  KOELKAST 1 DEUR 3 LADEN
-  KÜHLSCHRANK 1 TÜR 3 LADE
-  REFRIGERATOR 1 DOOR 3 DRAWERS
-  RÉFRIGÉRATEUR 1 PORTE 3 TIROIRS















	7450.0704			
		484x700x2010		368x580x1396
		350	GN	1x 1/1GN
	R	R 134 A		✓
		230V / 0,25kW		✓
		-2 / +8°C		✓
		130		X
€	1.990,- 			





FREEZER

-  VRIESKAST
-  TIEFKÜHLSCHRANK
-  FREEZER
-  CONGÉLATEUR















	7450.0702			
		484x700x2010		368x580x1396
		350	GN	3x 1/1GN
	R	R 404 A		✓
		230V / 0,65kW		✓
		-18 / -25°C		✓
		110		✓
€	1.660,- 			





REFRIGERATOR INCL. DRAWER

-  KOELKAST INCL. LADEN
-  KÜHLSCHRANK INKL. LADE
-  REFRIGERATOR INCL. DRAWER
-  RÉFRIGÉRATEUR INCL. TIROIRS













	7450.0710			
		680x800x2010		560x650x1386
		507	EN	7x EN 600x400
	R	R 134 A		✓
		230V / 0,28kW		✓
		+2 / +8°C		✓
		160		✓
€	1.960,- 			





REFRIGERATOR SS EXTERIOR

-  KOELKAST RVS BUITENKANT
-  KÜHLSCHRANK EDELSTAHL AUBENSEITE
-  REFRIGERATOR SS EXTERIOR
-  RÉFRIGÉRATEUR EN EXTÉRIEUR ACIER INOX













	7022.0008			
		600x630x1450		+2 / +10°C
		275		5x
		230V / 0,41kW		X
		50		✓
	€	499,- 		





FREEZER SS EXTERIOR











-  VRIESKAST RVS BUITENKANT
-  TIEFKÜHLSCHRANK EDELSTAHL AUBENSEITE
-  FREEZER SS EXTERIOR
-  CONGÉLATEUR EN EXTÉRIEUR ACIER INOX













	7022.0103			
		600x630x1450		-16 / -32°C
		275		2x
		230V / 0,69kW		X
		51		✓
	€	556,- 		

COUNTER DISPLAY COOLER











-  TAFELMODEL KOELKAST
-  KÜHLSCHRANK TISCHMODEL
-  COUNTER DISPLAY COOLER
-  RÉFRIGÉRATEUR POSABLE

	7022.0110			
		330x390x600		260x270x370
		21	R	R 134 A
		230V / 0,6kW		2x
		0 / +10°C		✓
		16		X
	€	329,- 		





	7022.0112			
		420x435x785		350x310x505
		52	R	R 134 A
		230V / 0,85kW		3x
		0 / +10°C		✓
		23		X
	€	349,- 		

MINIBAR

-  MINIBAR
-  MINIBAR
-  MINIBAR
-  MINIBAR





	7013.2565			
		405x443x545	R	R 134 A
		40		20x
		230V / 0,6kW		✓
		0 / +3°C		X
		13,2		✓
	€	186,- 		

REFRIGERATOR GLASS DOOR

-  KOELKAST GLASDEUR
-  KÜHLSCHRANK GLASTÜR
-  REFRIGERATOR GLASS DOOR
-  RÉFRIGÉRATEUR PORTE EN VERRE







REFRIGERATOR GLASS DOOR













-  KOELKAST GLASDEUR
-  KÜHLSCHRANK GLASTÜR
-  REFRIGERATOR GLASS DOOR
-  RÉFRIGÉRATEUR PORTE EN VERRE















REFRIGERATOR LOW TEMPERATURE



-  KOELKAST DIEPTEKOELING
-  KÜHLSCHRANK TIEF TEMPERATUR
-  REFRIGERATOR LOW TEMPERATURE
-  RÉFRIGÉRATEUR BASSE TEMPÉRATURE







	7455.1200			
		600x590x1900		520x472x1320
		310	R	R 134 A
		230V / 0,28kW		3x
		0 / +10°C		✓
		74		✓
€	610,-			X

	7455.1201			
		600x590x1900		3x
		310		✓
		230V / 0,28kW		✓
		+2 / +7°C		✓
		74		✓
€	630,-			













ACCESSORIES













	7455.1202	
	> 7455.1200	€ 20,- 

REFRIGERATOR GLASS DOOR





-  KOELKAST GLASDEUR
-  KÜHLSCHRANK GLASTÜR
-  REFRIGERATOR GLASS DOOR
-  RÉFRIGÉRATEUR PORTE EN VERRE















	7464.0085			
		595x650x2000		490x447x1570
		382	R	R 600 A
		230V / 0.36 kW		5x
		0 / +10°C		✓
		73,5		✓
€	650,-			✓













							R						€	
7464.0065	595x686x1811	495x555x967	230V / 0,51kW	-3 / +3°C	322	4x	R 134 A	✓	X	✓	X	✓	87	1599,- 
7464.0070	675x832x1989	572x660x1291	230V / 0,58kW	-3 / +3°C	584	5x	R 134 A	✓	X	✓	X	✓	128	1699,- 

REFRIGERATOR GLASS DOOR





-  KOELKAST GLASDEUR
-  KÜHLSCHRANK GLASTÜR
-  REFRIGERATOR GLASS DOOR
-  RÉFRIGÉRATEUR PORTE EN VERRE







	7455.1205		1100x680x1860		1009x519x1202
			585	R	R 134 A
			230V / 0,43kW		6x
			0 / +10°C		✓
			100		✓
		€	1.160,-		 X

	7455.1215		1100x680x2160		1009x519x1502
			780	R	R 134 A
			230V / 0,43kW		6x
			0 / +10°C		✓
			118		✓
		€	1.310,-		 X











ACCESSORIES











	7455.1217	>	7455.1205 - 7455.1215	€	25,-	
	7455.1218	>	7455.1205 - 7455.1215	4x	€	6,- 

REFRIGERATOR WITH SLIDING GLASS DOORS





-  KOELKAST SCHUIF GLASDEUREN
-  KÜHLSCHRANK MIT DOPPELTE SCHIEBEGLASTÜREN
-  REFRIGERATOR WITH SLIDING GLASS DOORS
-  RÉFRIGÉRATEUR AVEC PORTES COULISSANTES EN VERRE















	7464.0035		880x711x2000		805x530x1370
			700		0 / +10°C
			230V / 0,62kW		4x
			✓		✓
			136		
		€	1.575,-		













	7464.0045		1103x689x2000		1028x508x1355
			852		0 / +10°C
			230V / 0,45kW		4x
			✓		✓
			159		
		€	1.595,-		

FREEZER GLASS DOOR









-  VRIESKAST GLASDEUR
-  TIEFKÜHLSCHRANK GLASTÜR
-  FREEZER GLASS DOOR
-  CONGÉLATEUR PORTE EN VERRE







	7450.0156		680x720x1990		560x580x1270
			412	R	R 404 A
			230V / 0,25kW		5x
			-18 / -24°C		✓
			138		✓
		€	1.660,-		 X  X

	7450.0157		1370x720x1990		1250x580x1270
			920	R	R 404 A
			230V / 0,4kW		10x
			-18 / -24°C		✓
			227		✓
		€	2.470,-		 X  X













ACCESSORIES

	7451.0220	>	7450.0156	€	17,-	
	7451.0250	>	7450.0157	€	17,-	
	7451.0225	>	7450.0156	4x	€	6,- 
	7451.0226	>	7450.0157	4x	€	6,- 





FREEZER GLASS DOOR

-  VRIESKAST GLASDEUR
-  TIEFKÜHLSCHRANK GLASTÜR
-  FREEZER GLASS DOOR
-  CONGÉLATEUR PORTE EN VERRE





	7464.0055		640x670x2058		490x469x1570
			382	R	R 134 A
			230V / 0,25kW		5x
			-18 / -24°C		✓
			100		✓
		€	1.340,-		 X  ✓





BACKBAR COUNTER

-  KOELBUFFET
-  RÜCK-BÜFFET
-  BACKBAR COUNTER
-  COMPTOIR-BAR-ARRIÈRE







	7455.0700			
H	1670x560x866	R	R 134 A	
U	98		4x	
⚡	230V / 0,18kW		✓	
°C	+2 / +7°C		✓	
KG	129		8x	
€	1.740,-			



ACCESSORIES



	7455.0701			
>	7455.0700	€	25,-	
	7455.0702			
>	7455.0700	€	10,-	



BACKBAR COOLER BLACK

-  BARCOOLER ZWART
-  BARKÜHLER SCHWARZ
-  BARCOOLER BLACK
-  RÉFRIGÉRATEUR DE BAR NOIR





	7450.0315			
H	1462x513x860	⚡	230V / 50 Hz	
U	350	°C	0 / +10°C	
KG	100		4x	
€	1.335,-			

	7450.0320			
H	2002x513x860	⚡	230V / 50 Hz	
U	537	°C	0 / +10°C	
KG	125		6x	
€	1.560,-			

	7450.0325			
H	2542x513x860	⚡	230V / 50 Hz	
U	698	°C	0 / +10°C	
KG	150		8x	
€	1.898,-			

ACCESSORIES

	7450.0330			
>	7450.0315-7450.0320-7450.0325	€	485,-	



Cooking range

Drop-in

Ovens

Kitchen equipment

Refrigeration

Dishwashers

Neutral





Faucets

Ventilation

Pizzeria





Bakery

BACKBAR COOLER SILVER

-  BARKOELER ZILVER
-  BARKÜHLER SILBER
-  BACKBAR COOLER SILVER
-  RÉFRIGÉRATEUR DE BAR ARGENT







BACKBAR COOLER BLACK

-  BARKOELER ZWART
-  BARKÜHLER SCHWARZ
-  BACKBAR COOLER BLACK
-  RÉFRIGÉRATEUR DE BAR NOIR



BACKBAR COOLER BLACK SLIDING DOORS









-  BARKOELER ZWART SCHUIFDEUREN
-  BARKÜHLER SCHWARZ SCHIEBETÜREN
-  BACKBAR COOLER BLACK SLIDING DOORS
-  RÉFRIGÉRATEUR DE BAR NOIR PORTES COULISS



















BACKBAR COOLER











-  BARKOELER
-  BARKÜHLER
-  BACKBAR COOLER
-  RÉFRIGÉRATEUR DE BAR





















	7455.1330	H	900x500x900	R	R 134 A
	198		4x		230V / 0,24kW
	+2 / +10°C		✓		55
	€ 670,-		✓		









	7455.1300	H	500x500x900	R	R 134 A
	98		2x		230V / 0,18kW
	+2 / +10°C		✓		35
	€ 520,-		✓		











	7455.1315	H	900x500x900	R	R 134 A
	198		4x		230V / 0,24 kW
	0 / +10°C		✓		55
	€ 680,-		✓		









	7455.1345	H	600x515x1820	R	R 134 A
	293		2x		230V / 0,28kW
	+2 / +10°C		✓		75
	€ 828,-		✓		X

	7455.1335	H	1335x500x900	R	R 134 A
	298		6x		230V / 0,3kW
	+2 / +10°C		✓		80
	€ 845,-		✓		







	7455.1305	H	900x500x900	R	R 134 A
	198		4x		230V / 0,24kW
	+2 / +10°C		✓		55
	€ 670,-		✓		

	7455.1320	H	1335x500x900	R	R 134 A
	298		6x		230V / 0,3 kW
	0 / +10°C		✓		80
	€ 890,-		✓		





	7455.1350	H	900x515x1820	R	R 134 A
	458		3x		230V / 0,38kW
	+2 / +10°C		✓		100
	€ 1.125,-		✓		X

	7455.1310	H	1335x500x900	R	R 134 A
	298		6x		230V / 0,3kW
	+2 / +10°C		✓		80
	€ 845,-		✓		

ACCESSORIES











	7455.1346	>	7450.1345	€ 19,-	
	7455.1351	>	7450.1350	€ 25,-	
	7455.1352	>	7450.1345 - 7450.1350	4x € 6,-	











REFRIGERATED COUNTER











-  KOELWERKBANK
-  KÜHLTISCH
-  REFRIGERATED COUNTER
-  TABLE RÉFRIGÉRÉE

DEPTH 700 **GREY LABEL**









	7950.0080	 1360x700x850	 795x580x560
		 230V / 0,34kW	 R R 134 A
		 +2/+8	 GN 2x 1/1GN
		 115	 <input checked="" type="checkbox"/>
		 € 1.390,-	 <input checked="" type="checkbox"/>









	7950.0082	 1795x700x850	 1230x580x560
		 230V / 0,34kW	 R R 134 A
		 +2/+8	 GN 3x 1/1GN
		 160	 <input checked="" type="checkbox"/>
		 € 1.625,-	 <input checked="" type="checkbox"/>

	7950.0084	 2230x700x850	 1665x580x560
		 230V / 0,34kW	 R R 134 A
		 +2/+8	 GN 4x 1/1GN
		 190	 <input checked="" type="checkbox"/>
		 € 1.895,-	 <input checked="" type="checkbox"/>





ACCESSORIES

	7950.0002	 € 395,-	 <input checked="" type="checkbox"/>
	7450.0500	 € 28,-	 <input checked="" type="checkbox"/>













	7450.0505	 GN 1/1 GN	 € 22,-	 <input checked="" type="checkbox"/>
	7451.0010	4x	 € 66,-	 <input checked="" type="checkbox"/>
	7451.0009	6x	 € 99,-	 <input checked="" type="checkbox"/>











REFRIGERATED COUNTER











-  KOELWERKBANK
-  KÜHLTISCH
-  REFRIGERATED COUNTER
-  TABLE RÉFRIGÉRÉE

DEPTH 700









	7450.0080	 1360x700x850	 795x580x560
		 230V / 0,34kW	 R R 134 A
		 +2/+8	 GN 2x 1/1GN
		 115	 <input checked="" type="checkbox"/>
		 € 1.560,-	 <input checked="" type="checkbox"/>





	7450.0082	 1795x700x850	 1230x580x560
		 230V / 0,34kW	 R R 134 A
		 +2/+8	 GN 3x 1/1GN
		 160	 <input checked="" type="checkbox"/>
		 € 1.740,-	 <input checked="" type="checkbox"/>

	7450.0084	 2230x700x850	 1665x580x560
		 230V / 0,34kW	 R R 134 A
		 +2/+8	 GN 4x 1/1GN
		 190	 <input checked="" type="checkbox"/>
		 € 2.075,-	 <input checked="" type="checkbox"/>

ACCESSORIES











	7451.0005	 € 495,-	 <input checked="" type="checkbox"/>
	7450.0500	 € 28,-	 <input checked="" type="checkbox"/>











REFRIGERATED COUNTER UPSTAND











-  KOELWERKBANK OPSTAANDE RAND
-  KÜHLTISCH AUFKANTUNG
-  REFRIGERATED COUNTER UPSTAND
-  TABLE RÉFRIGÉRÉE BORD RELEVÉ









DEPTH 700



	7450.0780	 1360x700x850	 795x580x560
		 230V / 0,34kW	 R R 134 A
		 +2/+8	 GN 2x 1/1GN
		 115	 <input checked="" type="checkbox"/>
		 € 1.630,-	 <input checked="" type="checkbox"/>

	7450.0782	 1795x700x850	 1230x580x560
		 230V / 0,34kW	 R R 134 A
		 +2/+8	 GN 3x 1/1GN
		 160	 <input checked="" type="checkbox"/>
		 € 1.808,-	 <input checked="" type="checkbox"/>

	7450.0784	 2230x700x850	 1665x580x560
		 230V / 0,34kW	 R R 134 A
		 +2/+8	 GN 4x 1/1GN
		 190	 <input checked="" type="checkbox"/>
		 € 2.150,-	 <input checked="" type="checkbox"/>











	7450.0505	 GN 1/1 GN	 € 22,-	 <input checked="" type="checkbox"/>
	7451.0010	4x	 € 66,-	 <input checked="" type="checkbox"/>
	7451.0009	6x	 € 99,-	 <input checked="" type="checkbox"/>











REFRIGERATED COUNTER











-  KOELWERKBANK
-  KÜHLTISCH
-  REFRIGERATED COUNTER
-  TABLE RÉFRIGÉRÉE

DEPTH
600







	7450.0118			
	1360x600x850		795x480x560	
	230V / 0,34kW	R	R 134 A	
	+2/+8		2x	
	103		✓	
€	1.340,-			✓



	7450.0116			
	1795x600x850		1230x480x560	
	230V / 0,34kW	R	R 134 A	
	+2/+8		3x	
	145		✓	
€	1.560,-			✓

	7450.0114			
	2230x700x850		1665x480x560	
	230V / 0,34kW	R	R 134 A	
	+2/+8		4x	
	163		✓	
€	1.895,-			✓

ACCESSORIES

	7451.0150	€ 22,-	
	7451.0155	€ 28,-	











	7451.0010	4x	€ 66,-	
	7451.0009	6x	€ 99,-	









REFRIGERATED COUNTER









-  KOELWERKBANK
-  KÜHLTISCH
-  REFRIGERATED COUNTER
-  TABLE RÉFRIGÉRÉE

HEIGHT
650













	7450.0755			
	1360x700x650		795x580x340	
	230V / 0,34kW	R	R 134 A	
	+2/+8	GN	2x 1/1GN	
	85		✓	
€	1.280,-			✓

	7450.0760			
	1795x700x650		1230x580x340	
	230V / 0,34kW	R	R 134 A	
	+2/+8	GN	3x 1/1GN	
	130		✓	
€	1.450,-			✓

	7450.0765			
	2230x700x650		1665x580x340	
	230V / 0,34kW	R	R 134 A	
	+2/+8	GN	4x 1/1GN	
	160		✓	
€	1.630,-			✓

ACCESSORIES

	7450.0505	GN	1/1 GN	€ 22,-	
	7451.0010	4x	€ 66,-		
	7451.0009	6x	€ 99,-		

	7451.0195	€ 495,-	
	7451.0190	€ 339,-	
	7450.0500	€ 28,-	

Cooking range

Drop-in

Ovens

Kitchen equipment

Refrigeration

Dishwashers

Neutral





Faucets

Ventilation

Pizzeria













Bakery

REFRIGERATED COUNTER SINK













-  KOELWERKBANK SPOELBAK
-  KÜHLTISCH SPÜLBECKE
-  REFRIGERATED COUNTER SINK
-  TABLE RÉFRIGÉRÉE PLONGE

DEPTH 700







	7450.0210				
	1510x700x960		795x580x560		
	2x 1/1 GN		400x400x150		
	230V / 0,35kW		R R 134 A		
	-2/+8		✓		
	115		✓		
	€ 2.430,-				







	7450.0215				
	2020x700x960		1230x580x560		
	3x 1/1 GN		400x400x150		
	230V / 0,35kW		R R 134 A		
	-2/+8		✓		
	160		✓		
	€ 2.720,-				

ACCESSORIES

	7450.0500			€ 28,-	
	7450.0505				
	GN 1/1 GN			€ 22,-	















REFRIGERATED NEGATIVE COUNTER













-  VRIESWERKBANK
-  TIEFKÜHLTISCH
-  REFRIGERATED NEGATIVE COUNTER
-  TABLE CONGÉLATEUR

DEPTH 700









	7450.0081				
	1360x700x860		795x580x560		
	230V / 0,34kW		R R 404 A		
	-10/-20		GN 2x 1/1GN		
	103		✓		
	€ 1.890,-				✓



	7450.0083				
	1795x700x860		1280x580x560		
	230V / 0,34kW		R R 404 A		
	-10/-20		GN 3x 1/1GN		
	145		✓		
	€ 2.160,-				✓

ACCESSORIES

	7450.0500			€ 28,-	
	7450.0505				
	GN 1/1 GN			€ 22,-	
	7451.0010	4x		€ 66,-	
	7451.0009	6x		€ 99,-	



Cooking range

Drop-in

Ovens

Kitchen equipment

Refrigeration

Dishwashers

Neutral





Faucets

Ventilation

Pizzeria











Bakery











REFRIGERATED COUNTER











-  KOELWERKBANK
-  KÜHLTISCH
-  REFRIGERATED COUNTER
-  TABLE RÉFRIGÉRÉE

DEPTH
700











	7477.0025			
	1280x700x850		843x570x530	
	300	R	R 134 A	
	230V / 0,29kW	GN	2x 1/1GN	
	0 / +10°C		✓	
	122		✓	
€	1.995,-			

	7477.0030			
	1730x700x850		1320x570x530	
	460	R	R 134 A	
	230V / 0,29kW	GN	3x 1/1GN	
	0 / +10°C		✓	
	155		✓	
€	2.266,-			





	7477.0035			
	2180x700x850		1805x570x530	
	630	R	R 134 A	
	230V / 0,29kW	GN	4x 1/1GN	
	0 / +10°C		✓	
	188		✓	
€	2.520,-			

ACCESSORIES

	7477.1000			
GN	2x 1/2 GN	€	450,-	
	7477.1010	€	25,-	









	7450.0505			
GN	1/1 GN	€	22,-	
	7477.1030	€	103,-	









REFRIGERATED NEGATIVE COUNTER

-  VRIESWERKBANK
-  TIEFKÜHLTISCH
-  REFRIGERATED NEGATIVE COUNTER
-  TABLE CONGÉLATEUR







DEPTH
700



	7477.0155			
	1280x700x850		843x570x530	
	230V / 0,59kW	R	R 404 A	
	-18/-22		300	
	124			
€	2.695,-			

	7477.0160			
	1730x700x850		1320x570x530	
	230V / 0,59kW	R	R 404 A	
	-18/-22		460	
	157			
€	3.380,-			

ACCESSORIES

	7450.0505	€	22,-	
	7477.1010	€	25,-	
	7477.1030	€	103,-	



Cooking range

Drop-in

Ovens

Kitchen equipment

Refrigeration

Dishwashers

Neutral





Faucets

Ventilation

Pizzeria









Bakery

REFRIGERATED COUNTER



-  KOELWERKBANK
-  KÜHLTISCH
-  REFRIGERATED COUNTER
-  TABLE RÉFRIGÉRÉE

GREY LABEL





















7950.0110	
 900x700x870	 830x595x456
 230V / 0,34kW	R R 134 A
 +2 / +8°C	 <input checked="" type="checkbox"/>  <input checked="" type="checkbox"/>  <input checked="" type="checkbox"/>
 99	
€ 1.470,- 	

REFRIGERATED COUNTER









-  KOELWERKBANK
-  KÜHLTISCH
-  REFRIGERATED COUNTER
-  TABLE RÉFRIGÉRÉE





7450.0110	
 900x700x870	 830x595x456
 230V / 0,34kW	R R 134 A
 +2 / +8°C	 <input checked="" type="checkbox"/>  <input checked="" type="checkbox"/>  <input checked="" type="checkbox"/>
 99	
€ 1.570,- 	

7950.0106	
 900x700x870	 830x595x456
 230V / 0,34kW	R R 134 A
 +2 / +8°C	GN 2x 1/1GN
 82	 <input checked="" type="checkbox"/>  <input checked="" type="checkbox"/>  <input checked="" type="checkbox"/>
€ 815,- 	





















7450.0106	
 900x700x870	 830x595x456
 230V / 0,34kW	R R 134 A
 +2 / +8°C	GN 2x 1/1GN
 82	 <input checked="" type="checkbox"/>  <input checked="" type="checkbox"/>  <input checked="" type="checkbox"/>
€ 865,- 	











7950.0112	
 1365x700x870	 1295x595x456
 230V / 0,34kW	R R 134 A
 +2 / +8°C	GN 3x 1/1GN
 125	 <input checked="" type="checkbox"/>  <input checked="" type="checkbox"/>  <input checked="" type="checkbox"/>
€ 1.099,- 	



7450.0112	
 1365x700x870	 1295x595x456
 230V / 0,34kW	R R 134 A
 +2 / +8°C	GN 3x 1/1GN
 125	 <input checked="" type="checkbox"/>  <input checked="" type="checkbox"/>  <input checked="" type="checkbox"/>
€ 1.166,- 	







7950.0108	
 900x700x870	 830x595x456
 230V / 0,34kW	R R 134 A
 +2 / +8°C	GN 1x 1/1GN
 91	 <input checked="" type="checkbox"/>  <input checked="" type="checkbox"/>  <input checked="" type="checkbox"/>
€ 1.170,- 	











7450.0108	
 900x700x870	 830x595x456
 230V / 0,34kW	R R 134 A
 +2 / +8°C	GN 1x 1/1GN
 91	 <input checked="" type="checkbox"/>  <input checked="" type="checkbox"/>  <input checked="" type="checkbox"/>
€ 1.251,- 	

















ACCESSORIES

	7950.0001	€ 395,- 
	7450.0500	€ 28,- 
	7450.0505	€ 22,- 
	GN 1/1 GN	

7950.0113	
 1365x700x870	 1295x595x456
 230V / 0,34kW	R R 134 A
 +2 / +8°C	 <input checked="" type="checkbox"/>  <input checked="" type="checkbox"/>  <input checked="" type="checkbox"/>
 150	
€ 2.350,- 	

ACCESSORIES











	7451.0006	€ 395,- 
	7450.0500	€ 28,- 
	7450.0505	€ 22,- 
	GN 1/1 GN	

7450.0113	
 1365x700x870	 1295x595x456
 230V / 0,34kW	R R 134 A
 +2 / +8°C	 <input checked="" type="checkbox"/>  <input checked="" type="checkbox"/>  <input checked="" type="checkbox"/>
 150	
€ 2.400,- 	

SALADETTE







-  SALADETTE
-  SALADETTE
-  SALADETTE
-  SALADETTE





	7450.0725			
		435x700x870		365x595x456
		109	R	R 134 A
		230V / 0,17kW	GN	1x 1/1 GN
		+2 / +8		<input checked="" type="checkbox"/> <input checked="" type="checkbox"/>
		36		<input checked="" type="checkbox"/>
	€	722,-		













ACCESSORIES

	7451.0006	€ 395,-	
	7450.0500	€ 28,-	
	7450.0505	€ 22,-	
	GN 1/1 GN		











REFRIGERATED COUNTER

-  KOELWERKBANK
-  KÜHLTISCH
-  REFRIGERATED COUNTER
-  TABLE RÉFRIGÉRÉE







	7450.0730			
		435x700x870		365x595x456
		109	R	R 134 A
		230V / 0,12kW	GN	1x 1/1 GN
		+2 / +8		<input checked="" type="checkbox"/> <input checked="" type="checkbox"/>
		38		<input checked="" type="checkbox"/>
	€	768,-		











	7450.0735			
		435x700x870		365x595x456
		109	R	R 134 A
		230V / 0,12kW		1x 1/1 GN
		+2 / +8		<input checked="" type="checkbox"/> <input checked="" type="checkbox"/>
		46		
	€	1.090,-		

REFRIGERATED NEGATIVE COUNTER

-  VRIESWERKBANK
-  TIEFKÜHLTISCH
-  REFRIGERATED NEGATIVE COUNTER
-  TABLE CONGÉLATEUR



	7450.0079			
		943x700x855		830x595x411
		230V / 0,34kW	R	R 404 A
		-10 / -20	GN	2x 1/1 GN
		96		<input checked="" type="checkbox"/>
	€	1.330,-		<input checked="" type="checkbox"/>

SALADETTE

-  SALADETTE
-  SALADETTE
-  SALADETTE
-  SALADETTE









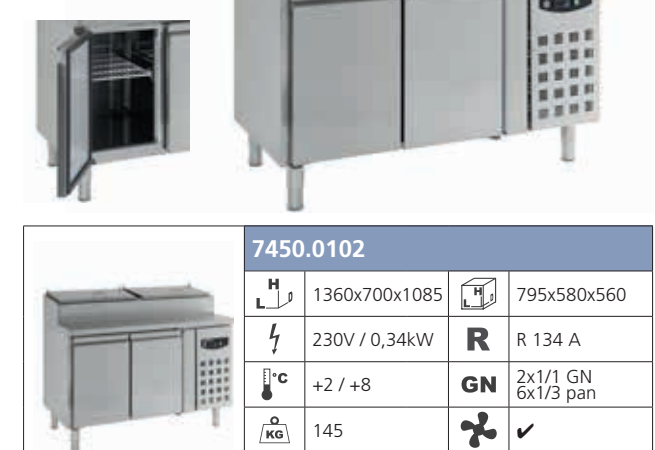

	7450.0225			
		903x700x980		830x590x456
		230V	GN	2x 1/1 GN
		+2 / +8		<input checked="" type="checkbox"/> <input checked="" type="checkbox"/>
		75		
	€	1.075,-		









SALADETTE

-  SALADETTE
-  SALADETTE
-  SALADETTE
-  SALADETTE







	7450.0102			
		1360x700x1085		795x580x560
		230V / 0,34kW	R	R 134 A
		+2 / +8	GN	2x 1/1 GN 6x 1/3 pan
		145		<input checked="" type="checkbox"/>
	€	1.980,-		<input checked="" type="checkbox"/>







	7450.0104			
		1795x700x1085		1230x580x560
		230V / 0,34kW	R	R 134 A
		+2 / +8	GN	3x 1/1 GN 8x 1/3 pan
		180		<input checked="" type="checkbox"/>
	€	2.130,-		<input checked="" type="checkbox"/>

ACCESSORIES













	7450.0500	€ 28,-	
	7450.0505	€ 22,-	
	GN 1/1 GN		
	7451.0010	4x	€ 66,-
	7451.0009	6x	€ 99,-

REFRIGERATED SALADETTE





-  GEKOELDE SALADETTE
-  GEKÜHLDE SALADETTE
-  REFRIGERATED SALADETTE
-  SALADETTE RÉFRIGÉRATÉE

GREY LABEL















	7950.0105	 900x700x870	 830x590x456
	230V / 0,34kW	 R 134 A	
	+2 / +8	 GN	2x 1/1 GN 2,5x 1/1 GN pan
	90		 
	799,-		

REFRIGERATED SALADETTE





-  GEKOELDE SALADETTE
-  GEKÜHLDE SALADETTE
-  REFRIGERATED SALADETTE
-  SALADETTE RÉFRIGÉRATÉE

GREY LABEL















	7950.0095	 903x700x1006	 830x590x456
	230V / 0,34kW	 R 134 A	
	+2 / +8	 GN	2x 1/1 GN 5x 1/6 GN pan
	72		 
	980,-		





REFRIGERATED SALADETTE

-  GEKOELDE SALADETTE
-  GEKÜHLDE SALADETTE
-  REFRIGERATED SALADETTE
-  SALADETTE RÉFRIGÉRATÉE















	7450.0105	 900x700x870	 830x590x456
	230V / 0,34kW	 R 134 A	
	+2 / +8	 GN	2x 1/1 GN 2,5x 1/1 GN pan
	90		 
	906,-		













REFRIGERATED SALADETTE

-  GEKOELDE SALADETTE
-  GEKÜHLDE SALADETTE
-  REFRIGERATED SALADETTE
-  SALADETTE RÉFRIGÉRATÉE















	7450.0095	 903x700x1006	 830x590x456
	230V / 0,34kW	 R 134 A	
	+2 / +8	 GN	2x 1/1 GN 5x 1/6 GN pan
	72		 
	1.086,-		















	7950.0094	 1370x700x870	 1295x595x456
	230V / 0,34kW	 R 134 A	
	+2 / +8	 GN	3x 1/1 GN 4x 1/1 GN pan
	125		 
	1.165,-		















	7950.0100	 1368x700x1006	 1295x595x456
	230V / 0,34kW	 R 134 A	
	+2 / +8	 GN	3x 1/1 GN 8x 1/6 GN pan
	140		 
	1.395,-		









	7450.0094	 1370x700x870	 1295x595x456
	230V / 0,34kW	 R 134 A	
	+2 / +8	 GN	3x 1/1 GN 4x 1/1 GN pan
	125		 
	1.210,-		









	7450.0100	 1368x700x1006	 1295x595x456
	230V / 0,34kW	 R 134 A	
	+2 / +8	 GN	3x 1/1 GN 8x 1/6 GN pan
	140		 
	1.564,-		





ACCESSORIES

	7450.0500		28,-	
	7450.0505		22,-	
	GN 1/1 GN			

ACCESSORIES









	7450.0500		28,-	
	7450.0505		22,-	
	GN 1/1 GN			

REFRIGERATED SALADETTE WITH GLASS COVER

-  GEKOELDE SALADETTE GLASOPSTAND
-  GEKÜHLTE SALADETTE MIT GLAS
-  REFRIGERATED SALADETTE WITH GLASS COVER
-  SALADETTE RÉFRIGÉRÉE AVEC VERRE









GREY LABEL







	7950.0400			
	900x700x850	R	R 134 A	
	230V / 0,34kW	GN	2x 1/1 GN 3x 1/6 GN pan	
	+2 / +8		✓	✓
	90			
	€ 996,-			

GREY LABEL







	7950.0405			
	1365x700x850	R	R 134 A	
	230V / 0,34kW	GN	3x 1/1 GN 4x 1/1 GN pan	
	+2 / +8		✓	✓
	125			
	€ 1.345,-			

ACCESSORIES









	7450.0500		€ 28,-	
	7450.0505			
GN	1/1 GN		€ 22,-	

REFRIGERATED COUNTER WITH GLAS COVER

-  KOELWERKBANK GLASOPSTAND
-  KÜHLTISCH MIT GLAS
-  REFRIGERATED COUNTER WITH GLAS COVER
-  TABLE RÉFRIGÉRÉE AVEC VERRE









GREY LABEL



	7950.0410			
	1360x700x1365	R	R 134 A	
	230V / 0,34kW	GN	2x 1/1 GN	
	+2 / +8		✓	✓
	115			
	€ 1.745,-			

GREY LABEL



	7950.0415			
	1795x700x1365	R	R 134 A	
	230V / 0,34kW	GN	3x 1/1 GN	
	+2 / +8		✓	✓
	160			
	€ 1.990,-			



Cooking range

Drop-in

Ovens

Kitchen equipment

Refrigeration

Dishwashers

Neutral





Faucets

Ventilation

















Pizzeria

Bakery









COLD AND FREEZER ROOM

-  KOELVRIESCEL
-  KÜHL UND FRIERZELL
-  COLD AND FREEZER ROOM
-  CHAMBRE FROID ET FRIGORIFIQUES







	L	D	H						€	
7469.1000	1360	1360	2200	1200x1200x2040	2.94	800	80	205	1.846,-	
7469.1035	1360	1660	2200	1200x1500x2040	3.67	800	80	248	2.165,-	
7469.1005	1360	1960	2200	1200x1800x2040	4.41	800	80	284	2.295,-	
7469.1040	1660	1660	2200	1500x1500x2040	4.59	800	80	288	2.295,-	
7469.1045	1660	1960	2200	1500x1800x2040	5.51	800	80	306	2.499,-	
7469.1050	1660	2260	2200	1500x2100x2040	6.43	800	80	342	2.725,-	
7469.1010	1960	1960	2200	1800x1800x2040	6.61	800	80	336	2.725,-	
7469.1020	1960	2260	2200	1800x2100x2040	7.71	800	80	378	2.925,-	
7469.1015	1960	2560	2200	1800x2400x2040	8.81	800	80	422	3.250,-	
7469.1025	1960	3160	2200	1800x3000x2040	11.2	800	80	492	3.550,-	









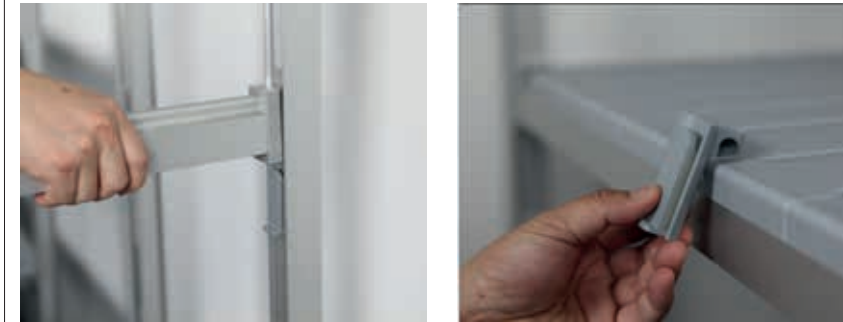





-  EXPORT OP AANVRAAG
-  EXPORT ON REQUEST
-  EXPORT AUF ANFRAGE
-  EXPORT SUR DEMANDE

7469.1055	2260	2260	2200	2100x2100x2040	9	800	80	480	3.195,-	
7469.1030	2560	2560	2200	2400x2400x2040	11.75	800	80	547	3.725,-	
7469.1200	2300	3500	2500	2100x3300x2300	15.94	800	100	740	5.292,-	
7469.1205	2900	2900	2500	2700x2700x2300	16.77	800	100	750	5.403,-	
7469.1210	2300	4100	2500	2100x3900x2300	18.84	800	100	822	5.911,-	
7469.1215	2900	3500	2500	2700x3300x2300	20.49	800	100	856	6.113,-	
7469.1220	2900	4100	2500	2700x3900x2300	24.22	800	100	948	6.823,-	
7469.1225	2900	5300	2500	2700x5100x2300	31.67	800	100	1043	8.243,-	





SHELVING SYSTEM

-  REKWERK
-  REGALSYSTEM
-  SHELVING SYSTEM
-  SYSTÈME DE RAYONNAGE



	>	L	D	H		€	
7013.2050	7469.1000	1075	450	1700	20	286,-	
7013.2055	7469.1035	1075/1350	450	1700	25	559,-	
7013.2060	7469.1005	1075/1650	450	1700	30	598,-	
7013.2065	7469.1040	1375/1350	450	1700	35	596,-	
7013.2070	7469.1045	1375/1650	450	1700	40	634,-	
7013.2075	7469.1050	1375/1950	450	1700	45	679,-	
7013.2080	7469.1010	1675/1650	450	1700	45	686,-	
7013.2085	7469.1020	1675/1950	450	1700	50	730,-	
7013.2090	7469.1015	1675/2240	450	1700	55	879,-	
7013.2095	7469.1025	1675/2840	450	1700	60	954,-	
7013.2100	7469.1055	1975/1950	450	1700	55	775,-	
7013.2105	7469.1030	2265/2240	450	1700	60	1.069,-	



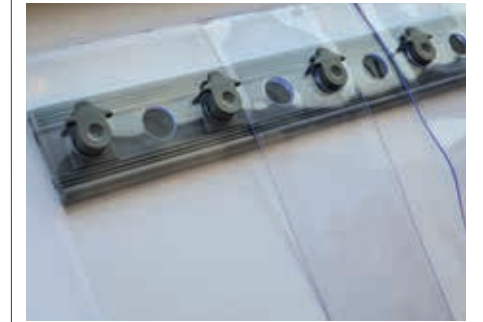

CURTAINS FOR COLD AND FREEZER ROOM

-  STROKENGORDIJN TBV CEL
-  VORHANG FÜR KÜHL- FRIERZELL
-  CURTAINS FOR COLD AND FREEZER ROOM
-  RIDEAU POUR CHAMBRE FROID ET FRIGORIFIQUE







7013.2235	
L	> 1050
H	> 2000
€	199,- 





POSITIVE WALL-MOUNTED UNIT

-  WANDUNIT KOEL
-  KÜHLAGGREGATE HUCKEPACK
-  POSITIVE WALL-MOUNTED UNIT
-  UNITÉ DE RÉFROIDISSEMENT TYPE POSITIF







	L	D	H	⚡	°C	MP ³	KG	€
7469.1125	490	807	704	230V / 0,6kW	0 / +10	3.5-9	57	1.360,- 
7469.1100	490	807	704	230V / 0,75kW	0 / +10	4-10.1	57	1.425,- 
7469.1105	490	807	704	230V / 0,79kW	0 / +10	6.5-12.6	61	1.625,- 
7469.1145	790	807	704	230V / 1,2kW	0 / +10	12-17	75	2.050,- 
7469.1130	790	807	704	400V / 3,4kW	0 / +10	30-42	90	3.375,- 





POSITIVE WALL-MOUNTED UNIT

-  WANDUNIT KOEL
-  KÜHLAGGREGATE HUCKEPACK
-  POSITIVE WALL-MOUNTED UNIT
-  UNITÉ DE RÉFROIDISSEMENT TYPE POSITIF







	L	D	H	⚡	°C	MP ³	KG	€
7480.0065	450	885	700	230 V / 0,9 kW	0 / +10	>6.23	79	2.171,- 
7480.0070	450	885	700	230 V / 1,4 kW	0 / +10	>12.46	80	2.401,- 
7480.0075	800	886	830	400 V / 2,5 kW	0 / +10	>26.16	133	3.801,- 
7480.0080	1147	886	830	400 V / 2,8 kW	0 / +10	>36.96	176	4.604,- 





NEGATIVE WALL-MOUNTED UNIT

-  WANDUNIT VRIES
-  TIEFKÜHLAGGREGATE HUCKEPACK
-  NEGATIVE WALL-MOUNTED UNIT
-  UNITÉ DE RÉFROIDISSEMENT TYPE NÉGATIF





	L	D	H	⚡	°C	MP ³	KG	€
7469.1120	490	807	704	230V / 1,2kW	-10 / -20	2.6-4.9	63	1.849,- 
7469.1110	790	807	704	230V / 1,3kW	-10 / -20	4.7-10.7	77	1.995,- 
7469.1140	790	807	704	400V / 2,1kW	-10 / -20	7.5-14.7	86	2.295,- 
7469.1115	790	807	704	400V / 2kW	-10 / -20	7.2-16.8	88	2.395,- 

NEGATIVE WALL-MOUNTED UNIT

-  WANDUNIT VRIES
-  TIEFKÜHLAGGREGATE HUCKEPACK
-  NEGATIVE WALL-MOUNTED UNIT
-  UNITÉ DE RÉFROIDISSEMENT TYPE NÉGATIF



	L	D	H	⚡	°C	MP ³	KG	€
7480.0085	450	885	700	230 V / 1 kW	-10 / -20	>7.65	84	2.708,- 
7480.0090	800	886	830	400 V / 2,2 kW	-10 / -20	>15.66	135	4.221,- 
7480.0095	1147	886	830	400 V / 2,7 kW	-10 / -20	>31.32	204	6.367,- 

POSITIVE SPLIT UNIT

- SPLIT UNIT KOEL
- KÜHLAGGREGAT SPLIT
- POSITIVE SPLIT UNIT
- UNITÉ RÉFROIDISSEMENT SPLIT TYPE POSITIF

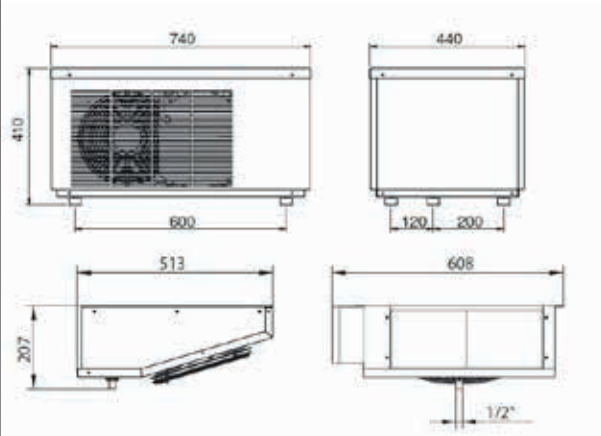

7480.0005

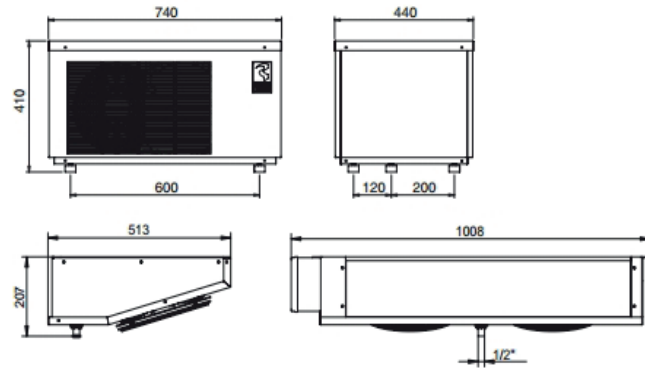

7480.0010 - 7480.0015

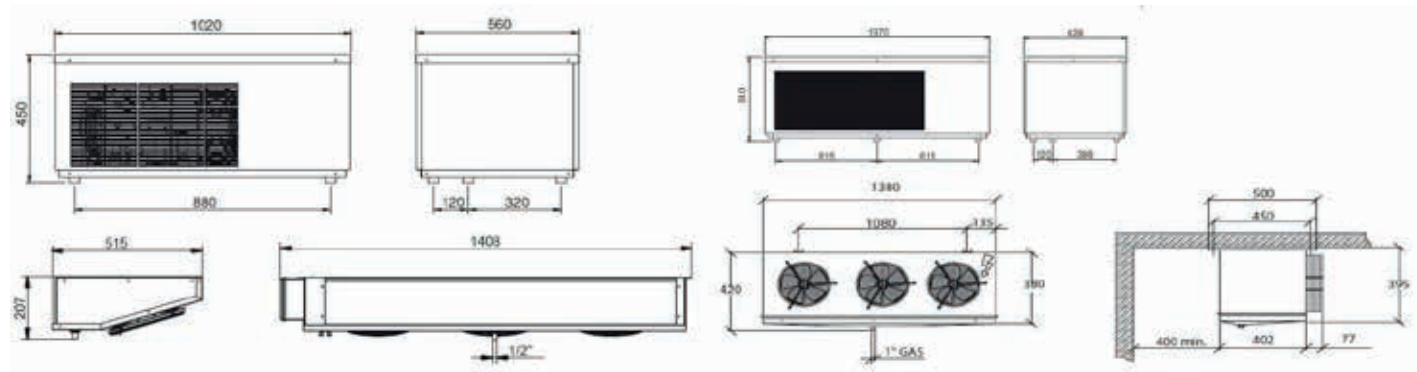

7480.0040

7480.0045

	L	D	H	⚡	°C	M³	A	KG	€
7480.0005	740 - 608	440 - 513	410 - 207	230V / 1,14kW	0 / +10	>6.64	✓	70	2.864,-
7480.0010	740 - 1008	440 - 513	410 - 207	230V / 1,28kW	0 / +10	>9.14	✓	80	3.232,-
7480.0015	740 - 1008	440 - 513	410 - 207	230V / 1,7kW	0 / +10	>11.63	✓	82	3.385,-
7480.0040	1020-1408	560 - 515	450 - 207	230V / 2,7kW	0 / +10	>26.48	✓	128	4.620,-
7480.0045	1370-1380	628 - 500	510 - 420	400V / 3,1kW	0 / +10	>38.43	✓	193	5.727,-

NEGATIVE SPLIT UNIT

- SPLIT UNIT VRIES
- TIEFKÜHLAGGREGAT SPLIT
- NEGATIVE SPLIT UNIT
- UNITÉ RÉFROIDISSEMENT SPLIT TYPE NÉGATIF

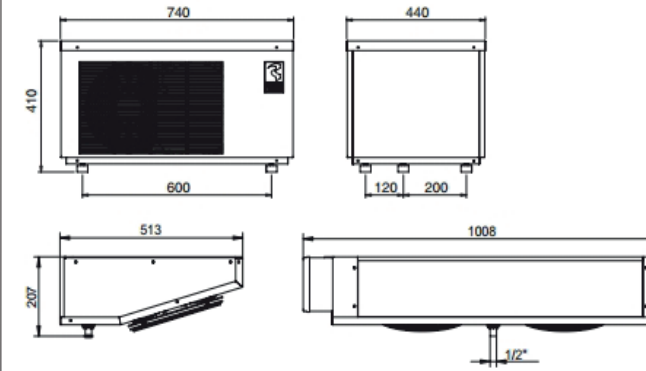

7480.0020 - 7480.0025

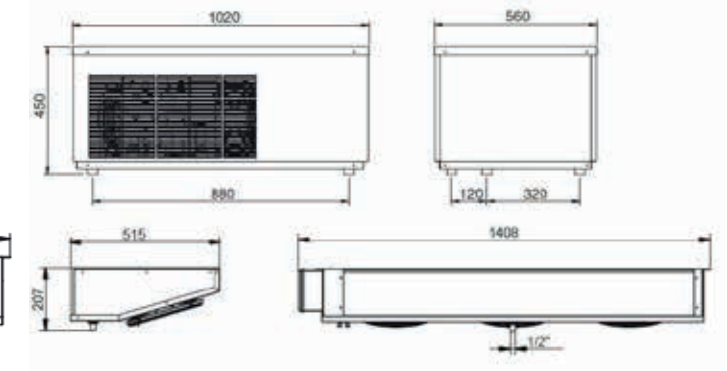



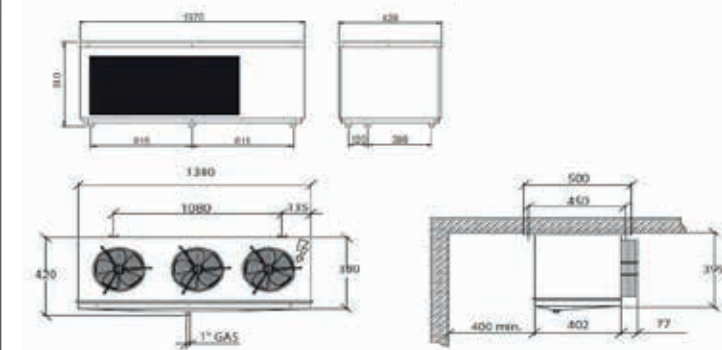

7480.0030













7480.0055 - 7480.0060











	L	D	H	⚡	°C	M³	A	KG	€
7480.0020	740 - 1008	440 - 513	410 - 207	230V / 1,14kW	-15/-25	>5.77	✓	88	3.331,-
7480.0025	740 - 1008	440 - 513	410 - 207	230V / 1,28kW	-15/-25	>11.96	✓	92	3.411,-
7480.0030	1020-1408	560 - 515	455 - 207	400V / 1,7kW	-15/-25	>11.96	✓	123	4.541,-
7480.0055	1370-1380	628 - 500	510 - 420	400V / 4,25kW	-15/-25	>22.99	✓	197	6.463,-
7480.0060	1370-1380	628 - 500	510 - 420	400V / 5,29kW	-15/-25	>36.62	✓	207	6.704,-











CHEST FREEZER GLASS COVER

-  VRIESKIST GLASDEKSEL
-  TIEFKÜHLTRUHE GLASDECKEL
-  CHEST FREEZER GLASS COVER
-  CONGÉLATEUR BAHUT COUVERCLE EN VERRE







	7450.1000	 1550x960x825	 1355x765x629
	230V / 0,41kW	 R	R 134 A
	-18 / -24°C		530
	96		✓
	€ 1.480,-		X











	7450.1005	 2050x960x825	 1855x765x629
	230V / 0,6kW	 R	R 134 A
	-18 / -24°C		750
	105		✓
	€ 1.720,-		X











	7450.1010	 2550x960x825	 2355x765x629
	230V / 0,6kW	 R	R 134 A
	-18 / -24°C		980
	125		✓
	€ 2.046,-		X

CHEST FREEZER SS COVER





-  VRIESKIST RVS DEKSEL
-  TIEFKÜHLTRUHE EDELSTAHL DECKEL
-  CHEST FREEZER SS COVER
-  CONGÉLATEUR BAHUT COUVERCLE EN INOX













	7450.0185	 753x553x811	 620x420x631
	230V / 0,12kW	 R	R 404 A
	-18 / -25°C		148
	43		
	€ 399,-		











	7450.0190	 953x553x811	 820x420x631
	230V / 0,15kW	 R	R 404 A
	-18 / -25°C		201
	48		
	€ 424,-		











CHEST FREEZER SS COVER

-  VRIESKIST RVS DEKSEL
-  TIEFKÜHLTRUHE EDELSTAHL DECKEL
-  CHEST FREEZER SS COVER
-  CONGÉLATEUR BAHUT COUVERCLE EN INOX











	7450.0168	 1330x637/680x830	 R	R 134 A
	230V / 0,13kW		390	
	-17 / -24°C		✓	
	71		✓	
	€ 607,-		X	





	7450.0170	 1604x675/720x860	 R	R 134 A
	230V / 0,13kW		526	
	-17 / -24°C		✓	
	92		✓	
	€ 758,-		X	

	7450.0172	 1850x745/795x885	 R	R 134 A
	230V / 0,19kW		768	
	-17 / -24°C		✓	
	112		✓	
	€ 996,-		X	











ACCESSORIES

	7451.0095	> 7450.0166	€ 17,-	
	7451.0100	> 7450.0168	€ 19,-	
	7451.0105	> 7450.0170	€ 21,-	
	7451.0110	> 7450.0172	€ 23,-	

CHEST FREEZER SS COVER

-  VRIESKIST RVS DEKSEL
-  TIEFKÜHLTRUHE EDELSTAHL DECKEL
-  CHEST FREEZER SS COVER
-  CONGÉLATEUR BAHUT COUVERCLE EN INOX





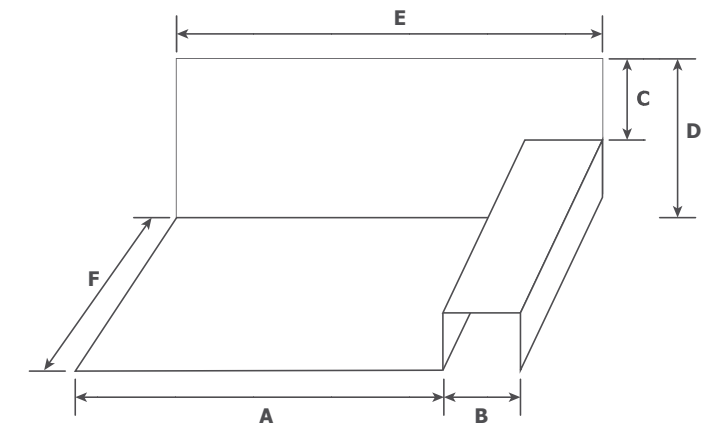



	7450.0166	 1055x575/630x845	 R	R 134 A
	230V / 0,13kW		260	
	-17 / -24°C		✓	
	60		✓	
	€ 469,-		X	







INTERNAL DIMENSIONS

	A	B	C	D	E	F
7450.0166	520	420	405	665	935	460
7450.0168	970	220	420	670	1190	190
7450.0170	1170	290	450	710	1450	520
7450.0172	1380	330	400	720	1710	600

	7451.0030	> 7450.0168	€ 28,-	
	7451.0032	> 7450.0170	€ 28,-	
	7451.0034	> 7450.0172	€ 32,-	

CHEST FREEZER GLASS COVER



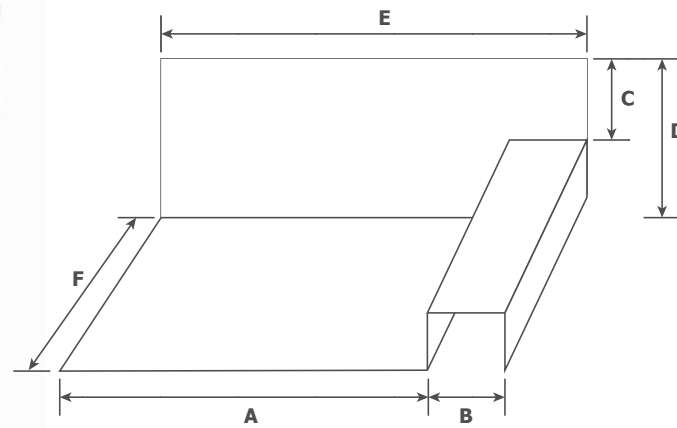

-  VRIESKIST GLASDEKSEL
-  TIEFKÜHLTRUHE GLASDECKEL
-  CHEST FREEZER GLASS COVER
-  CONGÉLATEUR BAHUT COUVERCLE EN VERRE



















INTERNAL DIMENSIONS

	A	B	C	D	E	F
7450.0174	720	230	335-400	595-660	945	470
7450.0176	780	300	310-380	570-640	1070	540





ACCESSORIES

	7451.0036	> 7450.0174	€ 24,-	
	7451.0038	> 7450.0176	€ 28,-	







	7450.0174
	 1073x596x840
	R R 134 A
	 230V / 0,13kW
	 236
	 -17 / -24°C
	 59
	 ✓
	€ 496,- 

	7450.0176
	 1199x665x865
	R R 134 A
	 230V / 0,13kW
	 328
	 -17 / -24°C
	 69
	 ✓
	€ 626,- 





ICECREAM CONSERVATOR

-  IJSCONSERVATEUR
-  SPEISEISKONSERVATOR
-  ICECREAM CONSERVATOR
-  CONSERVATEUR DE CREME GLACÉE









	7455.2010	7455.2015
	1044x694x850	1239x694x850
	-24/-18°C	-24/-18°C
R	R 134 A	R 134 A
	230V / 0,21kW	230V / 0,22kW
	✓	✓
	65	71
€	640,- 	740,- 

ICE CREAM DISPLAY

-  SCHEPIJSVITRINE
-  SPEISEISVITRINE
-  ICE CREAM DISPLAY
-  VITRINE À CREME GLACÉE







	7455.2000
	 1314x694x1315
	 -24/-18°C
	 230V / 0,24kW
	R R 134 A
	 73
	 9x5
	€ 1.090,- 







ACCESSORIES

	7455.2020 > 7455.2000	€ 22,-	
---	------------------------------	--------	---

ICE CREAM DISPLAY PRINTED

-  SCHEPIJSVITRINE BEDRUKT
-  SPEISEISVITRINE BEDRÜCKT
-  ICE CREAM DISPLAY PRINTED
-  VITRINE À CREME GLACÉE IMPRIMÉE







	7455.2005
	 1314x694x1315
	 -24/-18°C
	 230V / 0,24kW
	R R 134 A
	 73
	 9x5
	€ 1.110,- 









ACCESSORIES









	7455.2020 > 7455.2005	€ 22,-	
---	------------------------------	--------	---









BLASTCHILLER









-  BLASTCHILLER
-  SCHNELLKÜHLER
-  BLASTCHILLER.
-  REFRIGÉRISEUR À VENTILATION











	7477.0040			
	655x640x490		372x347x310	
	230V / 0,45kW	R	R 404 A	
	+90/+3 +90/-18	GN	3x 2/3	
	53		✓	
€	2.386,- 			

	7477.0045			
	680x725x850		553x375x303	
	230V / 0,56kW	R	R 404 A	
	+90/+3 +90/-18	GN	3x 1/1	
	77		✓	
€	2.850,- 			

	7477.0050			
	680x725x850		553x375x303	
	230V / 0,58kW	R	R 404 A	
	+90/+3 +90/-18	GN	5x 1/1	
	115		✓	
€	3.250,- 			











	7477.0060			
	820x860x1470		699x450x982	
	400V/1,65kW	R	R 404 A	
	+90/+3 +90/-18	GN	10x 1/1	
	120		✓	
€	5.435,- 			

	7477.0065			
	820x860x1820		699x450x982	
	400V/2,4kW	R	R 404 A	
	+90/+3 +90/-18	GN	15x 1/1	
	168		✓	
€	6.440,- 			





ICE CUBE MAKER

-  IJSBLOKJESMACHINE
-  EISWÜRFELMASCHINE
-  ICE CUBE MAKER
-  MACHINE DE GLAÇON







	L	D	H	⚡	R	🌀	KG/h			€
7453.0002	355	404	590	230V / 0,32kW	R 404 A	✓	20	4	31	899,- 
7453.0004	390	517	625	230V / 0,35kW	R 404 A	✓	25	6	41	1.260,- 
7453.0006	390	517	705	230V / 0,37kW	R 404 A	✓	29	9	48	1.306,- 
7453.0008	496	629	685	230V / 0,41kW	R 404 A	✓	34	16	56	1.479,- 
7453.0010	496	629	795	230V / 0,45kW	R 404 A	✓	43	25	64	1.679,- 
7453.0012	469	629	885	230V / 0,5kW	R 404 A	✓	53	25	70	1.795,- 
7453.0014	737	640	915	230V / 0,7kW	R 404 A	✓	68	40	89	2.250,- 
7453.0016	737	640	1015	230V / 0,85kW	R 404 A	✓	100	60	102	2.589,- 
7453.0018	840	740	1075	230V / 1,4kW	R 404 A	✓	155	65	138	3.380,- 

ICE FLAKE MACHINE

-  SCHILFERIJSMACHINE
-  SCHERBENEISERZEUGER
-  ICE FLAKE MACHINE
-  MACHINE À GLACE EN ECAILLES



	L	D	H	⚡	R	🌀	KG/h			€
7453.0020	496	660	685	230V / 0,55kW	R 404 A	✓	90	19	59	2.815,- 
7453.0022	741	678	925	230V / 0,65kW	R 404 A	✓	150	38	85	3.250,- 

Cooking range

Drop-in

Ovens

Kitchen equipment

Refrigeration

Dishwashers

Neutral

Faucets

Ventilation







Pizzeria







Bakery







ICE CUBE MAKER

-  IJSBLOKJESMACHINE
-  EISWÜRFELMASCHINE
-  ICE CUBE MAKER
-  MACHINE DE GLAÇON



	7453.0028		
	862x470x620		90
	230V / 0,85W	R	R 404 A
	100		
€	2.690,-		







	7453.0030		
	862x555x720		155
	230V / 1,4W	R	R 404 A
	120		
€	3.295,-		

	7453.0036		
	1250x580x848		300
	230V / 2,6W	R	R 404 A
	180		
€	5.375,-		

ICE CUBE MAKER

-  IJSBLOKJESMACHINE
-  EISWÜRFELMASCHINE
-  ICE CUBE MAKER
-  MACHINE DE GLAÇON













	7476.0150		
	420x528x655	R	R 134 A
	230V / 0,22kW		26
	36,5		6
€	649,-		

ICE STORAGE BIN

-  IJS OPSLAG BUNKER
-  RESERVEBEHÄLTER
-  ICE STORAGE BIN
-  CONTENEUR STOCKAGE INTÉGRÉ





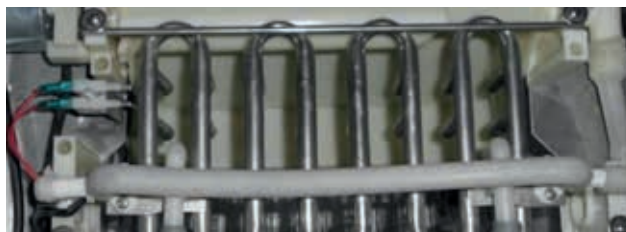

	7453.0032		
>	7453.0028		200
	7453.0030		110
	870x790x1000		110
€	1.575,-		



	7453.0038		
>	7453.0036		350
	1250x790x1000		150
€	2.250,-		





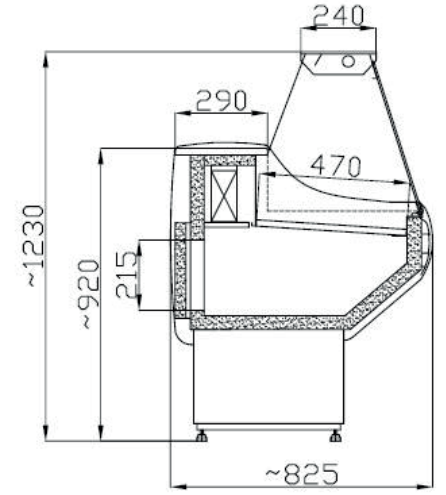

COLD DISPLAY VINNIE

-  KOELVITRINE VINNIE
-  KÜHLVITRINE VINNIE
-  COLD DISPLAY VINNIE
-  VITRINE RÉFRIGÉRATÉE VINNIE









	L	D	H	⚡	R	°C	🌬️	💡	🔌	📊	KG	€
7486.0005	1500	825	1230	230V / 0,63kW	R 404 A	+1/ +10	✓	✓	✓	175	1.787,-	
7486.0010	2000	825	1230	230V / 0,83kW	R 404 A	+1/ +10	✓	✓	✓	225	2.059,-	
7486.0015	2490	825	1230	230V / 0,83kW	R 404 A	+1/ +10	✓	✓	✓	275	2.465,-	

COLD DISPLAY EVELIEN

-  KOELVITRINE EVELIEN
-  KÜHLVITRINE EVELIEN
-  COLD DISPLAY EVELIEN
-  VITRINE RÉFRIGÉRATÉE EVELIEN



	7430.0048	7430.0052
	1500x810x1220	2050x810x1220
	+2 / +7	+2 / +7
R	R 134 A	R 134 A
	230V / 0,4kW	230V / 0,4kW
	✓	✓
	✓	✓
	200	220
€	2.195,-	2.586,-

Cooking range

Drop-in

Ovens

Kitchen equipment

Refrigeration

Dishwashers

Neutral





Faucets

Ventilation





Pizzerias

Bakery





COLD DISPLAY CURVED

-  KOELVITRINE GEBOGEN
-  GEBOGENE KÜHLVITRINE
-  COLD DISPLAY CURVED
-  VITRINE RÉFRIGÉRATÉE MODÈLE COURBÉE







	7430.0011	7430.0013	7430.0015
	1300x765x1180	1500x765x1180	1700x765x1180
	+2 / +7	+2 / +7	+2 / +7
R	R 134 A	R 134 A	R 134 A
	230V/0,308kW	230V/0,338kW	230V/0,355kW
	✓	✓	✓
	70	75	80
€	1.577,-	1.680,-	1.839,-





COLD DISPLAY RIGHT

-  KOELVITRINE RECHT
-  KÜHLVITRINE GERADE
-  COLD DISPLAY RIGHT
-  VITRINE RÉFRIGÉRATÉE MODÈLE DROIT







	7430.0005	7430.0007	7430.0009
	1300x765x1180	1500x765x1180	1700x765x1180
	+2 / +7	+2 / +7	+2 / +7
R	R 134 A	R 134 A	R 134 A
	230V/0,308kW	230V/0,338kW	230V/0,355kW
	✓	✓	✓
	70	75	80
€	1.577,-	1.680,-	1.839,-





COLD DISPLAY TABLE TOP CURVED

-  KOELVITRINE TAFELMODEL GEBOGEN
-  GEBOGENE KÜHLVITRINE TISCHMODEL
-  COLD DISPLAY TABLE TOP CURVED
-  VITRINE RÉFRIGÉRATÉE POSABLE MODÈLE COURBÉE







	7430.0022	7430.0023	7430.0025	7430.0027
	1000x945x710	1300x945x710	1500x945x710	1700x945x710
	+2 / +7	+2 / +7	+2 / +7	+2 / +7
R	R 134 A	R 134 A	R 134 A	R 134 A
	230V/0,308kW	230V/0,308kW	230V/0,338kW	230V / 0,55kW
	✓	✓	✓	✓
	55	65	70	75
€	1.299,-	1.490,-	1.580,-	1.695,-





COLD DISPLAY TABLE TOP RIGHT

-  KOELVITRINE TAFELMODEL RECHT
-  KÜHLVITRINE TISCHMODEL GERADE
-  COLD DISPLAY TABLE TOP RIGHT
-  VITRINE RÉFRIGÉRATÉE POSABLE MODÈLE DROIT









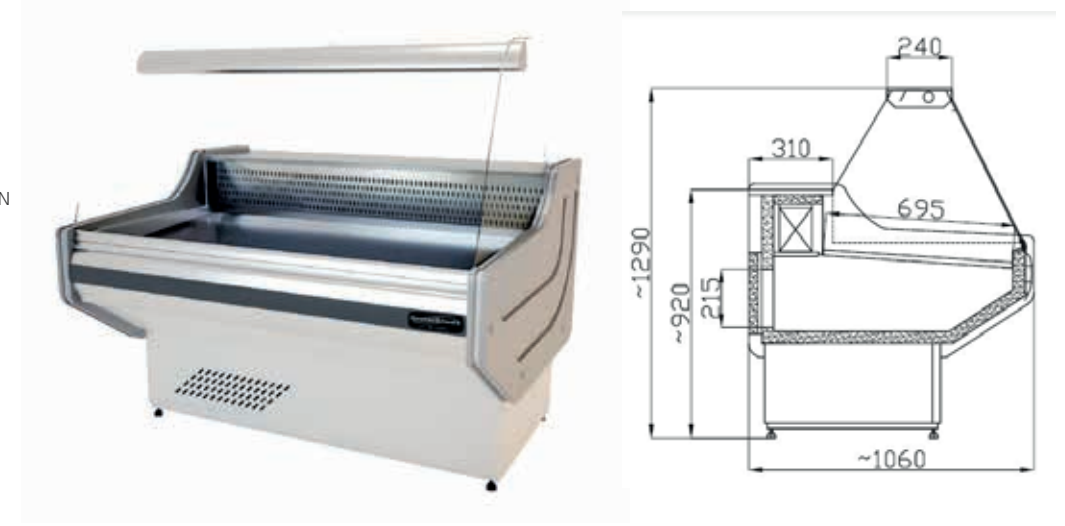

	7430.0016	7430.0017	7430.0019	7430.0021
	1000x945x710	1300x945x710	1500x945x710	1700x945x710
	+2 / +7	+2 / +7	+2 / +7	+2 / +7
R	R 134 A	R 134 A	R 134 A	R 134 A
	230V/0,308kW	230V/0,308kW	230V/0,338kW	230V / 0,55kW
	✓	✓	✓	✓
	55	65	70	75
€	1.299,-	1.490,-	1.580,-	1.695,-





COLD DISPLAY OWEN

-  KOELVITRINE OWEN
-  KÜHLVITRINE OWEN
-  COLD DISPLAY OWEN
-  VITRINE RÉFRIGÉRATÉE OWEN





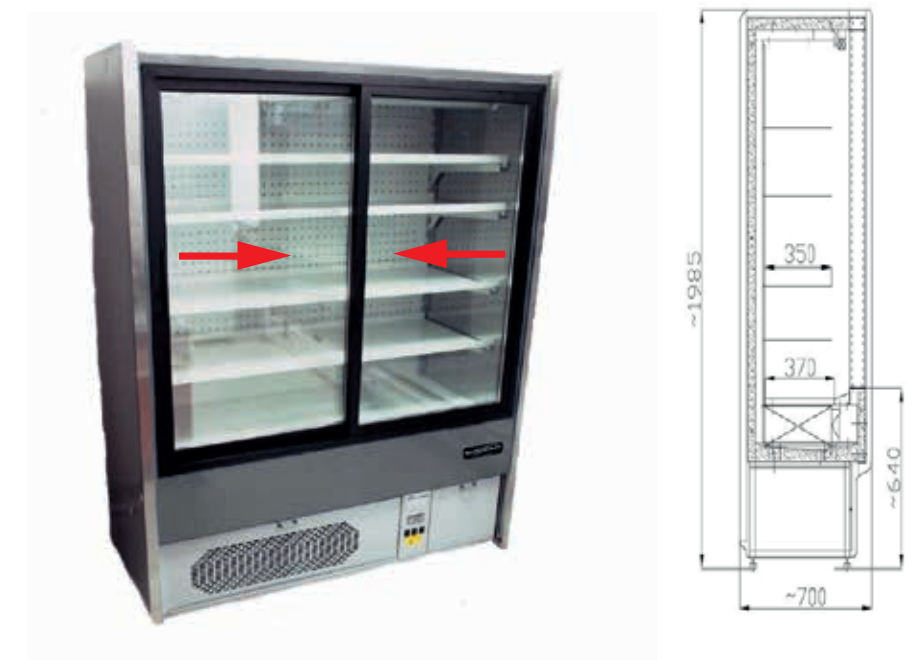

	L	D	H		R					€	
7486.0020	1500	1060	1310	230V / 0,36kW	R 404 A	+1 / +10	✓	✓	225	2.377,-	
7486.0025	2000	1060	1310	230V / 0,84kW	R 404 A	+1 / +10	✓	✓	250	2.674,-	
7486.0030	2490	1060	1310	230V / 1kW	R 404 A	+1 / +10	✓	✓	350	3.206,-	
				 EXPORT OP AANVRAAG	 EXPORT ON REQUEST						
				 EXPORT AUF ANFRAGE	 EXPORT SUR DEMANDE						
7486.0035	2940	1060	1310	230V / 1,3kW	R 404 A	+1 / +10	✓	✓	375	4.289,-	

WALL MOUNTED UNIT JEFFREY

-  WANDKOELING JEFFREY
-  WANDKÜHLUNG JEFFREY
-  WALL MOUNTED UNIT JEFFREY
-  CHAMBRE FROID MURALE JEFFREY



	L	D	H				LEVELS			€
7486.0040	910	700	1985	230V / 0,74kW	+1 / +10	✓	4	✓	160	2.854,-
7486.0045	1510	700	1985	230V / 0,9kW	+1 / +10	✓	4	✓	180	3.330,-
7486.0050	2010	700	1985	230V / 1,48kW	+1 / +10	✓	4	✓	200	4.020,-





COLD DISPLAY BEN

-  KOELVITRINE BEN
-  KÜHLVITRINE BEN
-  COLD DISPLAY BEN
-  VITRINE RÉFRIGÉRÉE BEN



	L	D	H	⚡	°C	🌀	🔌 A	KG	€
7430.0180	1290	1180	1225	230 V / 0,32 kW	+1/ +10	✓	✓	144	2.223,-
7430.0185	1920	1180	1225	230 V / 0,46 kW	+1/ +10	✓	✓	199	3.068,-
7430.0190	2460	1180	1225	230 V / 0,53 kW	+1/ +10	✓	✓	274	3.757,-





COLD DISPLAY SABRINA

-  KOELVITRINE SABRINA
-  KÜHLVITRINE SABRINA
-  COLD DISPLAY SABRINA
-  VITRINE RÉFRIGÉRÉE SABRINA



	L	D	H	⚡	°C	🌀	🔌 A	KG	€
7430.0160	1510	865	1230	230 V / 0,35 kW	+1/ +10	✓	✓	150	2.184,-
7430.0165	2050	865	1230	230 V / 0,46 kW	+1/ +10	✓	✓	190	2.995,-
7430.0170	2520	865	1230	230 V / 0,50 kW	+1/ +10	✓	✓	220	3.276,-

REFRIGERATED BUFFET

-  GEKOELD BUFFET
-  GEKÜHLTES BÜFFET
-  REFRIGERATED BUFFET
-  BUFFET RÉFRIGÉRÉ



	7478.0005		⚡	°C	🌀	🔌 A	KG	€
	H	1505x900x870/1320	230V / 0,57kW	+2 / +10°C	✓	R R 134 A	130	1.885,-
					GN	4/1 GN		
					✓	✓		

HOT BUFFET

-  WARM BUFFET
-  HEIßES BÜFFET
-  HOT BUFFET
-  BUFFET CHAUD



	7478.0010		⚡	°C	🌀	🔌 A	KG	€
	H	1505x900x870/1320	230V / 3kW	+30 / +90°C	✓	R R 134 A	130	1.590,-
					GN	4/1 GN		
					✓	✓		

SUSHI DISPLAY

-  SUSHIVITRINE
-  SUSHI VITRINE
-  SUSHI DISPLAY
-  VITRINE À SUSHI

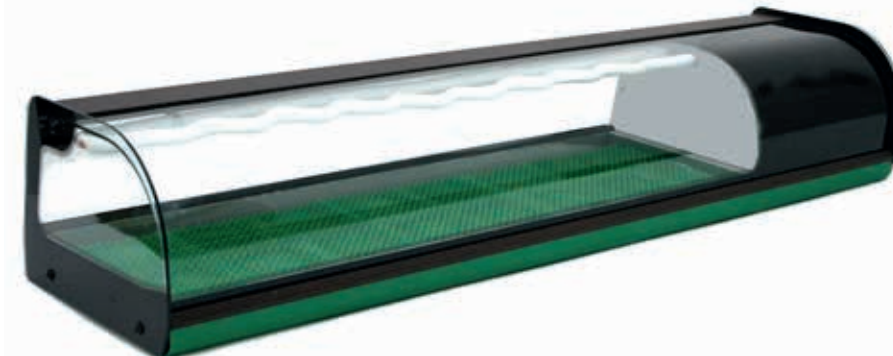













	L	D	H	H ₁ L	H ₁ D	⚡	°C	H ₂	KG	€
7479.0005	1090	370	285	805	305	230 V / 3,3 kW	+5/+10	805x305	33	1.225,-
7479.0010	1440	370	285	1260	305	230 V / 3,7 kW	+5/+10	1260x305	37	1.580,-
7479.0015	1790	370	285	1400	305	230 V / 3,9 kW	+5/+10	1400x305	43	1.850,-





COLD DISPLAY

-  KOELVITRINE
-  KÜHLVITRINE
-  COLD DISPLAY
-  VITRINE RÉFRIGÉRATÉE















	7450.0625	 428x386x960	 400x346x610
		 78	 3x
		 230V / 0,34kW	 R R 134 A
		 0 / +10°C	 ✓
		 36	 ✓
		€ 410,-	





DESSERT SHOW DISPLAY

-  GEBAKSVITRINE
-  GEBÄCKVITRINE
-  DESSERT SHOW DISPLAY
-  VITRINE DE PÂTISSERIE











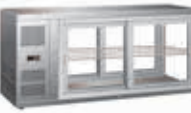



	7450.0745	 706x706x1300	 638x632x578
		 268	 GN 2x 1/1 GN
		 230V / 0,48kW	 R R 134 A
		 +2 / +10°C	 ✓
		 96	 ✓
		€ 1.230,-	





DESSERT SHOW DISPLAY

-  GEBAKSVITRINE
-  GEBÄCKVITRINE
-  DESSERT SHOW DISPLAY
-  VITRINE DE PÂTISSERIE



	7450.0600	 1110x510x550	 770x430x760
		 150	 1x
		 230V / 0,34kW	 R R 134 A
		 +2 / +12°C	 ✓
		 58	 ✓
		€ 1.050,-	











DESSERT SHOW DISPLAY

-  GEBAKSVITRINE
-  GEBÄCKVITRINE
-  DESSERT SHOW DISPLAY
-  VITRINE DE PÂTISSERIE







COLD DISPLAY





-  KOELVITRINE
-  KÜHLVITRINE
-  COLD DISPLAY
-  VITRINE RÉFRIGÉRATÉE

	7450.0740	 494x600x1740	 3x
		 220	 R R 134 A
		 230V / 0,58kW	 ✓
		 0 / +10°C	 ✓
		 106	
		€ 1.691,-	







ACCESSORIES

	7451.0230		
	> 7450.0600	€ 25,-	
	7451.0225		
	> 7450.0600	4x € 6,-	





COLD DISPLAY SHAUN

-  KOELVITRINE SHAUN
-  KÜHLVITRINE SHAUN
-  COLD DISPLAY SHAUN
-  VITRINE RÉFRIGÉRATÉE SHAUN









	7430.0090	 810x770x610	 +2 / +8°C
		 230V / 1,3kW	 GN 2/1
		 52	
		€ 1.575,-	





COLD DISPLAY SHAUN

-  KOELVITRINE SHAUN
-  KÜHLVITRINE SHAUN
-  COLD DISPLAY SHAUN
-  VITRINE RÉFRIGÉRATÉE SHAUN









	7430.0091	 1320x770x610	 +2 / +8°C
		 230V / 2,1kW	 GN 3/1
		 60	
		€ 1.930,-	





HOT DISPLAY SHAUN

-  WARMHOUDVITRINE SHAUN
-  WÄRMEVITRINE SHAUN
-  HOT DISPLAY SHAUN
-  VITRINE CHAUD SHAUN









	7430.0092	 800x770x610	 +40 / +90°C
		 230V / 1,8kW	 GN 2/1
		 50	
		€ 1.595,-	

HOT DISPLAY SHAUN

-  WARMHOUDVITRINE SHAUN
-  WÄRMEVITRINE SHAUN
-  HOT DISPLAY SHAUN
-  VITRINE CHAUD SHAUN



	7430.0094	 1300x770x610	 +40 / +90°C
		 230V / 1,8kW	 GN 3/1
		 60	
		€ 2.125,-	

Cooking range

Drop-in

Ovens

Kitchen equipment

Refrigeration

Dishwashers

Neutral

Faucets

Ventilation













Pizzeria

Bakery

COLD DISPLAY

-  KOELVITRINE
-  KÜHLVITRINE
-  COLD DISPLAY
-  VITRINE RÉFRIGÉRATÉE















7450.0605			
	682x450x675		659x412x369
	100		1x
	230V / 0,34kW		R 134 A
	0 / +12°C		✓
	39		✓
	€ 558,-		

COLD DISPLAY

-  KOELVITRINE
-  KÜHLVITRINE
-  COLD DISPLAY
-  VITRINE RÉFRIGÉRATÉE













7450.0610			
	678x568x670		673x530x380
	120		2x
	230V / 0,16kW		R 134 A
	0 / +12°C		✓
	64		✓
	€ 710,-		

COLD DISPLAY

-  KOELVITRINE
-  KÜHLVITRINE
-  COLD DISPLAY
-  VITRINE RÉFRIGÉRATÉE









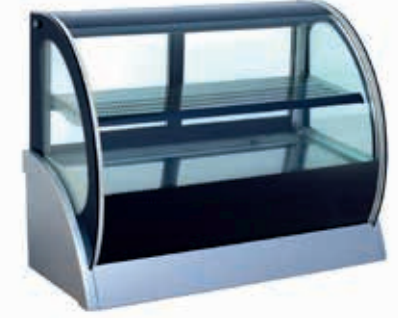



7450.0640			
	900x540x790		1x
	140		R 134 A
	230V / 0,5kW		✓
	+2 / +8°C		✓
	90		
	€ 2.039,-		

COLD DISPLAY

-  KOELVITRINE
-  KÜHLVITRINE
-  COLD DISPLAY
-  VITRINE RÉFRIGÉRATÉE











7450.0645			
	900x540x790		1x
	115		R 134 A
	230V / 0,5kW		✓
	+2 / +8°C		✓
	90		
	€ 1.919,-		

HOT DISPLAY

-  WARMHOUDVITRINE
-  WÄRMEVITRINE
-  HOT DISPLAY
-  VITRINE CHAUD











7450.0615			
	682x450x675		659x412x369
	100		1x
	230V / 0,34kW		+30 / +90°C
	39		
	€ 530,-		

HOT DISPLAY

-  WARMHOUDVITRINE
-  WÄRMEVITRINE
-  HOT DISPLAY
-  VITRINE CHAUD











7450.0620			
	678x568x670		673x530x380
	120		2x
	230V / 0,8kW		+30 / +90°C
	48		
	€ 680,-		

HOT DISPLAY

-  WARMHOUDVITRINE
-  WÄRMEVITRINE
-  HOT DISPLAY
-  VITRINE CHAUD











7450.0630			
	900x540x790		1x
	140		+40 / +70°C
	230V / 0,77kW		
	80		
	€ 1.689,-		

HOT DISPLAY

-  WARMHOUDVITRINE
-  WÄRMEVITRINE
-  HOT DISPLAY
-  VITRINE CHAUD



7450.0635			
	900x540x790		1x
	115		+40 / +70°C
	230V / 0,77kW		
	90		
	€ 1.629,-		



Vaatwassers
Spülmaschine
Dishwashers
Lave-vaisselles

GLASS WASHER ECO40

- GLAZENSPOLER ECO40
mechanische bediening, enkelwandig
- GLÄSERSPÜLMASCHINE ECO40
mechanische steuerung, einwandig
- GLASS WASHER ECO40
mechanical control, single skin
- LAVE-VAISSELLE À VERRES ECO40
commande mécanique, simple paroi



	7401.0105				
H	495x515x735	⏱	30 / H		
⚡	230 V/2,8 kW	⌚	120 SEC		
📏	270	🍽	1x		
⚖	38	🍷	1x		
€	1.395,-	🌱			

DISHWASHER ECO50 FRONTLOADER

- VAATWASSER ECO50 VOORLADER
mechanische bediening, enkelwandig
- GESCHIRRSPÜLMASCHINE ECO50 FRONTBEDIENUNG
mechanische steuerung, einwandig
- DISH WASHER ECO50 FRONTLOADER
mechanical control, single skin
- LAVE-VAISSELLE ECO50 CHARGEMENT PAR L'AVANT
commande mécanique, simple paroi



	7401.0020				
H	580x600x825	⏱	18 / H		
⚡	230 / 400 V 3,4 / 6,6 kW	⌚	200 SEC		
📏	340	🍽	1x		
⚖	54	🍷	1x		
€	1.730,-	🌱			

DISHWASHER PME50 FRONTLOADER

- VAATWASSER PME50 VOORLADER
digitale bediening, dubbelwandig
- GESCHIRRSPÜLMASCHINE PME50 FRONTBEDIENUNG
electr. Steuerung, doppelwandig
- DISHWASHER PME50 FRONTLOADER
digital control, double skin
- LAVE-VAISSELLE PME50 CHARGEMENT PAR L'AVANT
commande digital, double paroi



	7401.0125				
H	600x600x840	⏱	18 / H		
⚡	230 V/3,4 kW	⌚	200 SEC		
📏	340	🍽	1x		
⚖	55	🍷	1x		
€	2.099,-	🌱			

DISHWASHER ECO50 FRONTLOADER EXPORT

- VAATWASSER ECO50 VOORLADER EXPORT
mechanische bediening, enkelwandig
- GESCHIRRSPÜLMASCHINE ECO50 FRONTBEDIENUNG EXPORT
mechanische steuerung, einwandig
- DISH WASHER ECO50 FRONTLOADER EXPORT
mechanical control, single skin
- LAVE-VAISSELLE ECO50 CHARGEMENT PAR L'AVANT EXPORT
commande mécanique, simple paroi



	7401.0115				
H	580x600x825	⏱	18 / H		
⚡	230 V/4,8 kW	⌚	200 SEC		
📏	340	🍽	1x		
⚖	54	🍷	1x		
€	1.969,-	🚚			

POT WASHER AP1

- PANNENWASSER AP1
digitale bediening, dubbelwandig
- TOPFSPÜLMASCHINE AP1
electr. Steuerung, doppelwandig
- POT WASHER AP1
digital control, double skin
- LAVE-MARMITES AP1
commande digital, double paroi



	7401.0135				
H	720x780x2000/2200				
⚡	400 V / 7,4 kW	⌚	120-240-480 SEC		
📏	650				
⚖	150				
€	6.749,-	🚚			

POT WASHER AP2

- PANNENWASSER AP2
digitale bediening, dubbelwandig
- TOPFSPÜLMASCHINE AP2
electr. Steuerung, doppelwandig
- POT WASHER AP2
digital control, double skin
- LAVE-MARMITES AP2
commande digital, double paroi



	7401.0140				
H	720x780x2210/2440				
⚡	400 V / 8 kW	⌚	120-240-480 SEC		
📏	850				
⚖	168				
€	7.869,-	🚚			

POT WASHER AP5

- PANNENWASSER AP5
digitale bediening, dubbelwandig
- TOPFSPÜLMASCHINE AP5
electr. Steuerung, doppelwandig
- POT WASHER AP5
digital control, double skin
- LAVE-MARMITES AP5
commande digital, double paroi

	7401.0155				
H	1470x850x1930/2440				
⚡	400 V / 15,5 kW	⌚	120-720 SEC		
📏	850				
⚖	260				
€	17.589,-	🚚			



Cooking range
Drop-in
Ovens
Kitchen equipment
Refrigeration
Dishwashers
Neutral
Faucets
Ventilation
Pizzeria
Bakery

PASS-THROUGH DISH WASHER ECO1000

- DOORSCHUIF VAATWASSER ECO1000
mechanische bediening, enkelwandig
- DURSCHUBSPÜLMASCHINE ECO 1000
mechanische steuerung, einwandig
- PASS-THROUGH DISH WASHER ECO1000
mechanical control, single skin
- LAVE-VAISSELLE À CONVOYEUR ECO1000
commande mécanique, simple paroi



PASS-THROUGH DISH WASHER CF1201AE

- DOORSCHUIF VAATWASSER CF1201AE
digitale bediening, dubbelwandig
- DURSCHUBSPÜLMASCHINE CF1201AE
electr. Steuerung, doppelwandig
- PASS-THROUGH DISH WASHER CF1201AE
digital control, double skin
- LAVE-VAISSELLE À CONVOYEUR CF1201AE
commande digital, double paroi



	7401.0025			
	H	645x710x1490/1940		
	⚡	400 V / 9,8 kW	⌚	60-200 SEC
	D	420		1x
	KG	150		1x
	€	3.040,-		1x

	7401.0030			
	H	710x710x2145		
	⚡	400 V / 9,8 kW	⌚	60-240-360 SEC
	D	420		1x
	KG	150		1x
	€	4.149,-		1x

RACK CONVEYOR DISH WASHER AC1

- KORVENTRANSPORTMACHINE AC1
digitale bediening, dubbelwandig
- KORBTRANSPORTSPÜLMASCHINE AC1
electr. Steuerung, doppelwandig
- RACK CONVEYOR DISH WASHER AC1
digital control, double skin
- LAVE-VAISSELLE TRANSPORTEUR EN RACK AC1
commande digital, double paroi

	7401.0160			
	H	1150x770x1565		
	⚡	400 V / 55,2 kW	⌚	100 / H
	D	400		
	KG	150		
	€	11.499,-		



EXIT TABLE BOTTEM SHELF LEFT

- AFVOERTAFEL BODEMSCHAP
Tafel links van machine
- ABFUHRTISCH GRUNDBODEN
Tisch auf der linken Seite
- EXIT TABLE BOTTEM SHELF
Table left side of machine
- TABLE D'ÉCOULEMENT ÉTAGÈRE 700
Table a gauche de machine



L	D	H	KG	€
700	720	900	24	617,-
1000	720	900	31	641,-
1200	720	900	36	727,-
1500	720	900	43	762,-
1700	720	900	48	814,-

EXIT TABLE BOTTEM SHELF RIGHT

- AFVOERTAFEL BODEMSCHAP
Tafel rechts van machine
- ABFUHRTISCH GRUNDBODEN
Tisch auf der rechten Seite
- EXIT TABLE BOTTEM SHELF
Table right side of machine
- TABLE D'ÉCOULEMENT ÉTAGÈRE 700
Table a droite de machine



L	D	H	KG	€
700	720	900	24	617,-
1000	720	900	31	641,-
1200	720	900	36	727,-
1500	720	900	43	762,-
1700	720	900	48	814,-

EXIT TABLE TWO LEGS RIGHT

- AFVOERTAFEL TWEE POTEN
Tafel links van machine
- ABFUHRTISCH LINKS ZWEI BEINE
Tisch auf der linken Seite
- EXIT TABLE TWO LEGS
Table left side of machine
- TABLE D'ÉCOULEMENT DEUX PIEDS
Table a gauche de machine



L	D	H	KG	€
700	720	900	8	221,-
1000	720	900	10	256,-

EXIT TABLE TWO LEGS LEFT

- AFVOERTAFEL TWEE POTEN
Tafel rechts van machine
- ABFUHRTISCH LINKS ZWEI BEINE
Tisch auf der rechten Seite
- EXIT TABLE TWO LEGS
Table right side of machine
- TABLE D'ÉCOULEMENT DEUX PIEDS
Table a droite de machine



L	D	H	KG	€
700	720	900	8	221,-
1000	720	900	10	256,-

Cooking range

Drop-in

Ovens

Kitchen equipment

Refrigeration

Dishwashers

Neutral





Faucets

Ventilation







Pizzeria

Bakery





ENTRY TABLE OPEN FRAME LEFT

-  AANVOERTAFEL OPEN ONDERSCHAP
Tafel links van machine
-  ZUFUHRTISCH OFFENEM UNTERBAU
Tisch auf der linken Seite
-  ENTRY TABLE OPEN FRAME
Table left side of machine
-  TABLE D'APPROVISIONEMENT ESSOUS OUVERT
Table a gauche de machine









L	D	H	 / KG	€	
700	720	900	34	855,-	
1000	720	900	42	933,-	
1200	720	900	47	987,-	
1500	720	900	55	1.004,-	
1700	720	900	60	1.232,-	





ENTRY TABLE OPEN FRAME RIGHT

-  AANVOERTAFEL OPEN ONDERSCHAP
Tafel rechts van machine
-  ZUFUHRTISCH OFFENEM UNTERBAU
Tisch auf der rechten Seite
-  ENTRY TABLE OPEN FRAME
Table right side of machine
-  TABLE D'APPROVISIONEMENT ESSOUS OUVERT
Table a droite de machine









L	D	H	 / KG	€	
700	720	900	34	855,-	
1000	720	900	42	933,-	
1200	720	900	47	987,-	
1500	720	900	55	1.004,-	
1700	720	900	60	1.232,-	





ENTRY TABLE BOTTEM SHELF RIGHT

-  AANVOERTAFEL BODEMSCHAP
Tafel links van machine
-  ZUFUHRTISCH GRUNDBODEN
Tisch auf der linken Seite
-  ENTRY TABLE BOTTEM SHELF
Table left side of machine
-  TABLE D'APPROVISIONEMENT ÉTAGÈRE
Table a gauche de machine









L	D	H	 / KG	€	
700	720	900	40	958,-	
1000	720	900	50	1.063,-	
1200	720	900	57	1.100,-	
1500	720	900	68	1.285,-	
1700	720	900	75	1.371,-	





ENTRY TABLE BOTTEM SHELF LEFT

-  AANVOERTAFEL BODEMSCHAP
Tafel rechts van machine
-  ZUFUHRTISCH GRUNDBODEN
Tisch auf der rechten Seite
-  ENTRY TABLE BOTTEM SHELF
Table right side of machine
-  TABLE D'APPROVISIONEMENT ÉTAGÈRE
Table a droite de machine









L	D	H	 / KG	€	
700	720	900	40	958,-	
1000	720	900	50	1.063,-	
1200	720	900	57	1.100,-	
1500	720	900	68	1.285,-	
1700	720	900	75	1.371,-	





ENTRY TABLE OPEN FRAME WITH WASTE HOLE LEFT

-  AANVOERTAFEL OPEN ONDERSCHAP MET AFVALGAT
Tafel links van machine
-  ZUFUHRTISCH OFFENEM GRUNDBODEN MIT ABFALLOCH
Tisch auf der linken Seite
-  ENTRY TABLE OPEN FRAME WITH WASTE HOLE
Table left side of machine
-  TABLE D'APPROVISIONEMENT ESSOUS OUVERT AVEC TROU DÉCHETS
Table a gauche de machine









L	D	H	 / KG	€	
1000	720	900	43	1.065,-	
1200	720	900	48	1.119,-	
1500	720	900	56	1.137,-	
1700	720	900	61	1.364,-	





ENTRY TABLE OPEN FRAME WITH WASTE HOLE RIGHT

-  AANVOERTAFEL OPEN ONDERSCHAP MET AFVALGAT
Tafel rechts van machine
-  ZUFUHRTISCH OFFENEM GRUNDBODEN MIT ABFALLOCH
Tisch auf der rechten Seite
-  ENTRY TABLE OPEN FRAME WITH WASTE HOLE
Table right side of machine
-  TABLE D'APPROVISIONEMENT ESSOUS OUVERT AVEC TROU DÉCHETS
Table a droite de machine









L	D	H	 / KG	€	
1000	720	900	43	1.065,-	
1200	720	900	48	1.119,-	
1500	720	900	56	1.137,-	
1700	720	900	61	1.364,-	





ENTRY TABLE 1/2 BOTTOM SHELF WITH WASTE HOLE RIGHT

-  AANVOERTAFEL 1/2 BODEMSCHAP MET AFVALGAT
Tafel links van machine
-  ZUFUHRTISCH 1/2 GRUNDBODEN MIT ABFALLOCH
Tisch auf der linken Seite
-  ENTRY TABLE 1/2 BOTTOM SHELF WITH WASTE HOLE
Table left side of machine
-  TABLE D'APPROVISIONEMENT 1/2 ÉTAGÈRE AVEC TROU DÉCHETS
Table a gauche de machine









L	D	H	 / KG	€	
1000	720	900	45	1.283,-	
1200	720	900	52	1.343,-	
1500	720	900	62	1.513,-	
1700	720	900	71	1.591,-	

ENTRY TABLE 1/2 BOTTOM SHELF WITH WASTE HOLE LEFT

-  AANVOERTAFEL 1/2 BODEMSCHAP MET AFVALGAT
Tafel rechts van machine
-  ZUFUHRTISCH 1/2 GRUNDBODEN MIT ABFALLOCH
Tisch auf der rechten Seite
-  ENTRY TABLE 1/2 BOTTOM SHELF WITH WASTE HOLE
Table right side of machine
-  TABLE D'APPROVISIONEMENT 1/2 ÉTAGÈRE AVEC TROU DÉCHETS
Table a droite de machine



L	D	H	 / KG	€	
1000	720	900	45	1.283,-	
1200	720	900	52	1.343,-	
1500	720	900	62	1.513,-	
1700	720	900	71	1.591,-	

Cooking range

Drop-in

Ovens

Kitchen equipment

Refrigeration

Dishwashers

Neutral

Faucets

Ventilation

Pizzeria

Bakery

DISHWASHER DETERGENT

- VAATWASMIDDEL
- GESCHIRRSPÜLMITTEL
- DISHWASHER DETERGENT
- PRODUIT VAISSELLE

	7050.0055
	10
€	38,-

DRAIN PUMP ECO50

- AFVOERPOMP ECO50
- ABWASSERPUMPE ECO50
- DRAIN PUMP ECO50
- POMPE D'ÉCOULEMENT ECO50

	7401.0021
	1
€	185,-

PLATE BASKET

- BORDENKORF
- TELLERKORB
- PLATE BASKET
- PANIER À ASSIETTES

	7013.0330
	500x500x101
	2
€	21,-

RINSING AGENT

- NAGLANSMIDDEL
- KLARSPÜLMITTEL
- RINSING AGENT
- LIQUIDE DE RINÇAGE

	7050.0070
	10
€	56,-



DETERGENT INJECTOR

- ZEEPDOSEERPOMP VOOR ECO40/50/1000
- SPÜLMITTELDOSIERER FÜR ECO 40/50/1000
- DETERGENT INJECTOR FOR ECO 40/50/1000
- DOSEUR À DÉTERGENT POUR ECO 40/50/1000

	7401.0022
	1
€	185,-

UNIVERSAL BASKET

- UNIVERSEELKORF
- UNIVERSAL KORB
- UNIVERSAL BASKET
- PANIER UNIVERSEL

	7013.0310
	500x500x101
	2
€	18,-

SUPPORT FOR FRONTLOADER

- ONDERSTEL VOOR VOORLADER
- UNTERGESTELL FÜR GESCHIRRSPÜLMACHINE
- SUPPORT FOR FRONTLOADER
- BASE POUR LAVE-VAISSELLE PAR L'AVANT

	7455.0005
	600x550x450
	4
€	215,-

SS WASHING ARMS

- RVS WASARMEN VOOR ECO50/1000
- EDELSTAHL SPÜLARME FÜR ECO50/1000
- SS WASHING ARMS FOR ECO50/1000
- GICLEURS EN ACIER INOX POUR ECO50/1000

	7401.0023
	2x
	5
€	182,-

CUTLERY BASKET

- BESTEKKORF
- BESTECKKORB
- CUTLERY BASKET
- PANIER À COUVERT

	7013.0305
	500x500x101
	2
€	18,-

GLASS BASKET

- GLAZENKORF
- GLASKORB
- GLASS BASKET
- PANIER À VERRES



	L	D	H		KG	€
7013.0315	500	500	143	16x	2	28,-
7013.0320	500	500	143	25x	2	30,-
7013.0325	500	500	143	36x	2	32,-

GLASS BASKET

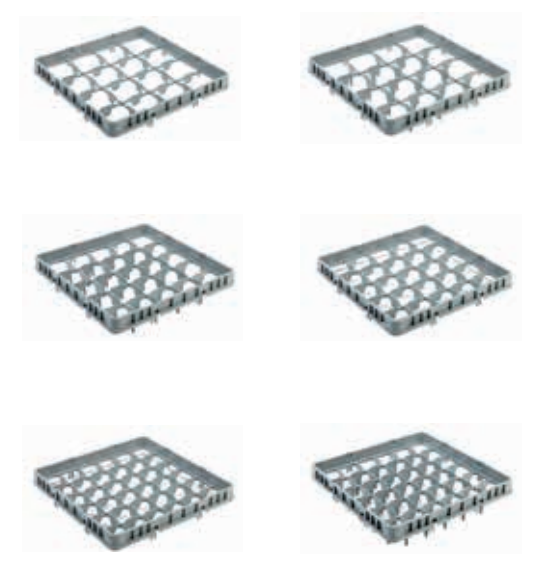

- GLAZENKORF
- GLASKORB
- GLASS BASKET
- PANIER À VERRES



	L	D	H		KG	€
7013.0345	500	500	75	16x	1	10,-
7013.0340	500	500	120	16x	1	10,-
7013.0355	500	500	75	25x	1	10,-
7013.0350	500	500	120	25x	1	12,-
7013.0365	500	500	75	36x	1	10,-
7013.0360	500	500	120	36x	1	13,-

OPEN FRAME

- OPZETRAND OPEN
- AUFZATS OFFEN
- OPEN FRAME
- ENCADREMENT OUVERT

	7013.0370
	500x500x75
	
€	8,-

LID FOR BASKET

- DEKSEL VOOR VAATWASKORF
- DECKEL FÜR KORB
- LID FOR BASKET
- COUVERCLE POUR PANIER

	7013.0335
	500x500x1
	5
€	15,-

BASKET TROLLEY

- KORVENTRANSPORTWAGEN
- GESCHIRRKORBWAGEN
- BASKET TROLLEY
- TROLLEY POUR PANIERS DE LAVAGE

	7013.0375
	530x530x920
	10
€	77,-



Neutraal
Neutral
Neutral
Neutral

Cooking range

Drop-in

Ovens

Kitchen equipment

Refrigeration

Dishwashers

Neutral

Faucets

Ventilation

Pizzeria

Bakery

WORKTABLE BOTTEM SHELF FLAT PAKED

- WERKTAFEL BODEMSCHAP DEMONTABEL
- ARBEITSTISCH GRUNDBODEN DEMONTABEL
- WORKTABLE BOTTEM SHELF FLAT PAKED
- PLAN DE TRAVAIL ÉTAGÈRE DÉMONTABLE



600 LINE	L	D	H	KG	€
7452.3102	800	600	850	36	249,-
7452.3103	1000	600	850	42	269,-
7452.3105	1200	600	850	46	283,-
7452.3106	1400	600	850	52	317,-
7452.3110	1600	600	850	60	334,-
7452.3112	1800	600	850	64	371,-
7452.3115	2000	600	850	68	384,-

700 LINE	L	D	H	KG	€
7452.3120	800	700	850	36	252,-
7452.3125	1000	700	850	42	273,-
7452.3130	1200	700	850	46	298,-
7452.3135	1400	700	850	52	324,-
7452.3140	1600	700	850	60	346,-
7452.3145	1800	700	850	64	376,-
7452.3150	2000	700	850	68	391,-

WORKTABLE BOTTEM SHELF UPSTAND FLAT PAKED

- WERKTAFEL BODEMSCHAP RAND DEMONTABEL
- ARBEITSTISCH GRUNDBODEN AUFKANTUNG DEMONTABEL
- WORKTABLE BOTTEM SHELF UPSTAND FLAT PAKED
- PLAN DE TRAVAIL ÉTAGÈRE BORD RELEVÉ DÉMONTABLE



600 LINE	L	D	H	KG	€
7452.3152	800	600	850	37	264,-
7452.3153	1000	600	850	43	283,-
7452.3155	1200	600	850	47	308,-
7452.3157	1400	600	850	53	340,-
7452.3160	1600	600	850	61	364,-
7452.3162	1800	600	850	65	393,-
7452.3165	2000	600	850	69	403,-

700 LINE	L	D	H	KG	€
7452.3170	800	700	850	31	270,-
7452.3175	1000	700	850	42	294,-
7452.3180	1200	700	850	46	319,-
7452.3185	1400	700	850	52	350,-
7452.3190	1600	700	850	60	379,-
7452.3195	1800	700	850	64	406,-
7452.3200	2000	700	850	68	432,-

ACCESSORIES

	7452.5000	400x685x190	8	€ 151,-
	7452.5005	400x685x580	32	€ 371,-
	4x			€ 161,-

WORKTABLE BOTTEM SHELF

- WERKTAFEL BODEMSCHAP
- ARBEITSTISCH GRUNDBODEM
- WORKTABLE BOTTEM SHELF
- PLAN DE TRAVAIL ÉTAGÈRE







600 LINE	L	D	H	KG	€	700 LINE	L	D	H	KG	€	800 LINE	L	D	H	KG	€			
7812.0040	700	600	900	38	277,-	7812.0003	700	700	900	40	277,-	7812.0062	700	800	900	37	304,-			
7812.0039	800	600	900	42	291,-	7812.0004	800	700	900	43	306,-	7812.0063	800	800	900	39	321,-			
7812.0041	900	600	900	39	306,-	7812.0008	900	700	900	45	323,-	7812.0080	900	800	900	41	339,-			
7812.0042	1000	600	900	41	321,-	7812.0005	1000	700	900	47	325,-	7812.0064	1000	800	900	43	355,-			
7812.0043	1100	600	900	43	339,-	7812.0006	1100	700	900	49	359,-	7812.0065	1100	800	900	45	377,-			
7812.0044	1200	600	900	45	355,-	7812.0010	1200	700	900	51	360,-	7812.0066	1200	800	900	47	396,-			
7812.0045	1300	600	900	47	369,-	7812.0011	1300	700	900	53	393,-	7812.0067	1300	800	900	49	412,-			
7812.0047	1400	600	900	51	384,-	7812.0012	1400	700	900	57	391,-	7812.0081	1400	800	900	53	429,-			
7812.0046	1500	600	900	55	399,-	7812.0015	1500	700	900	61	414,-	7812.0068	1500	800	900	57	446,-			
7812.0058	1600	600	900	59	413,-	7812.0017	1600	700	900	66	424,-	7812.0069	1600	800	900	61	465,-			
7812.0059	1700	600	900	63	427,-	7812.0018	1700	700	900	69	458,-	7812.0082	1700	800	900	65	481,-			
7812.0048	1800	600	900	68	444,-	7812.0020	1800	700	900	74	453,-	7812.0070	1800	800	900	70	497,-			
7812.0049	1900	600	900	72	458,-	7812.0021	1900	700	900	79	489,-	7812.0071	1900	800	900	74	514,-			
7812.0050	2000	600	900	75	473,-	7812.0025	2000	700	900	84	485,-	7812.0072	2000	800	900	79	532,-			
7812.0051	2100	600	900	78	566,-	7812.0026	2100	700	900	86	601,-	7812.0073	2100	800	900	84	631,-			
7812.0060	2200	600	900	82	581,-	7812.0027	2200	700	900	90	618,-	7812.0083	2200	800	900	88	647,-			
7812.0052	2300	600	900	86	596,-	7812.0030	2300	700	900	94	634,-	7812.0074	2300	800	900	92	665,-			
7812.0053	2400	600	900	90	610,-	7812.0031	2400	700	900	98	651,-	7812.0075	2400	800	900	96	683,-			
7812.0061	2500	600	900	94	624,-	7812.0032	2500	700	900	102	666,-	7812.0084	2500	800	900	100	700,-			
7812.0054	2600	600	900	98	639,-	7812.0035	2600	700	900	106	683,-	7812.0076	2600	800	900	104	716,-			
7812.0055	2700	600	900	102	644,-	7812.0036	2700	700	900	110	698,-	7812.0077	2700	800	900	108	734,-			
7812.0056	2800	600	900	106	669,-	7812.0037	2800	700	900	114	715,-	7812.0078	2800	800	900	112	752,-			
7812.0057	2900	600	900	110	684,-	7812.0038	2900	700	900	118	731,-	7812.0079	2900	800	900	116	768,-			



ACCESSORIES

	7003.0250	400x630x590	128	€ 495,-
	4x			€ 161,-
	6x			€ 241,-

WORKTABLE OPEN FRAME

-  WERKTAFEL OPEN ONDERSTEL
-  ARBEITSTISCH OFFENEM UNTERBAU
-  WORKTABLE OPEN FRAME
-  PLAN DE TRAVAIL ESSOUS OUVERT







600 LINE						700 LINE						800 LINE					
L	D	H	KG	€		L	D	H	KG	€		L	D	H	KG	€	
																	
7812.0137	700	600	900	33	270,-	7812.0186	700	700	900	35	282,-	7812.0193	700	800	900	37	296,-
7812.0138	800	600	900	37	282,-	7812.0187	800	700	900	38	292,-	7812.0194	800	800	900	39	307,-
7812.0139	900	600	900	39	292,-	7812.0188	900	700	900	40	306,-	7812.0195	900	800	900	41	321,-
7812.0140	1000	600	900	41	304,-	7812.0154	1000	700	900	42	319,-	7812.0170	1000	800	900	43	335,-
7812.0141	1100	600	900	43	315,-	7812.0155	1100	700	900	44	331,-	7812.0171	1100	800	900	45	347,-
7812.0142	1200	600	900	45	328,-	7812.0156	1200	700	900	46	344,-	7812.0172	1200	800	900	47	360,-
7812.0143	1300	600	900	47	339,-	7812.0157	1300	700	900	48	354,-	7812.0173	1300	800	900	49	373,-
7812.0200	1400	600	900	51	351,-	7812.0189	1400	700	900	52	368,-	7812.0196	1400	800	900	53	386,-
7812.0144	1500	600	900	55	362,-	7812.0158	1500	700	900	56	382,-	7812.0174	1500	800	900	57	400,-
7812.0145	1600	600	900	59	374,-	7812.0159	1600	700	900	60	393,-	7812.0175	1600	800	900	61	412,-
7812.0201	1700	600	900	63	386,-	7812.0190	1700	700	900	64	406,-	7812.0197	1700	800	900	65	426,-
7812.0146	1800	600	900	68	397,-	7812.0160	1800	700	900	69	419,-	7812.0176	1800	800	900	70	440,-
7812.0147	1900	600	900	72	408,-	7812.0161	1900	700	900	73	430,-	7812.0177	1900	800	900	74	452,-
7812.0148	2000	600	900	75	420,-	7812.0162	2000	700	900	77	444,-	7812.0178	2000	800	900	79	466,-
																	
7812.0149	2100	600	900	78	519,-	7812.0163	2100	700	900	81	543,-	7812.0179	2100	800	900	84	570,-
7812.0202	2200	600	900	82	530,-	7812.0191	2200	700	900	85	554,-	7812.0198	2200	800	900	88	583,-
7812.0150	2300	600	900	86	542,-	7812.0164	2300	700	900	89	568,-	7812.0180	2300	800	900	92	596,-
7812.0151	2400	600	900	90	553,-	7812.0165	2400	700	900	93	581,-	7812.0181	2400	800	900	96	610,-
7812.0203	2500	600	900	94	566,-	7812.0192	2500	700	900	97	592,-	7812.0199	2500	800	900	100	622,-
7812.0152	2600	600	900	98	577,-	7812.0166	2600	700	900	101	605,-	7812.0182	2600	800	900	104	636,-
7812.0153	2700	600	900	102	588,-	7812.0167	2700	700	900	105	618,-	7812.0183	2700	800	900	108	647,-
7812.0204	2800	600	900	106	599,-	7812.0168	2800	700	900	109	630,-	7812.0184	2800	800	900	108	661,-
7812.0205	2900	600	900	106	611,-	7812.0169	2900	700	900	113	643,-	7812.0185	2900	800	900	116	676,-

ACCESSORIES

	4x	€ 161,-
	6x	€ 241,-



WORKTABLE ½ BOTTOM SHELF

-  WERKTAFEL ½ BODEMSCHAP
-  ARBEITSTISCH ½ GRUNDBODEN
-  WORKTABLE ½ BOTTOM SHELF
-  PLAN DE TRAVAIL ½ ÉTAGÈRE







600 LINE					700 LINE					800 LINE							
L	D	H	KG	€	L	D	H	KG	€	L	D	H	KG	€			
7812.0350	1000	600	900	41	371,-	7812.0360	1000	700	900	42	390,-	7812.0370	1000	800	900	43	409,-
7812.0351	1100	600	900	43	390,-	7812.0361	1100	700	900	44	411,-	7812.0371	1100	800	900	45	430,-
7812.0352	1200	600	900	45	406,-	7812.0362	1200	700	900	46	427,-	7812.0372	1200	800	900	47	450,-
7812.0353	1300	600	900	47	420,-	7812.0363	1300	700	900	48	444,-	7812.0373	1300	800	900	49	466,-
7812.0346	1400	600	900	51	435,-	7812.0398	1400	700	900	52	459,-	7812.0491	1400	800	900	53	482,-
7812.0354	1500	600	900	55	450,-	7812.0364	1500	700	900	56	475,-	7812.0374	1500	800	900	57	499,-
7812.0355	1600	600	900	59	463,-	7812.0365	1600	700	900	60	492,-	7812.0375	1600	800	900	61	518,-
7812.0386	1700	600	900	63	478,-	7812.0399	1700	700	900	64	508,-	7812.0492	1700	800	900	65	534,-
7812.0356	1800	600	900	68	493,-	7812.0366	1800	700	900	69	524,-	7812.0376	1800	800	900	70	550,-
7812.0387	1900	600	900	72	508,-	7812.0480	1900	700	900	73	530,-	7812.0377	1900	800	900	74	568,-
7812.0358	2000	600	900	75	523,-	7812.0368	2000	700	900	77	558,-	7812.0378	2000	800	900	79	585,-
7812.0388	2100	600	900	78	587,-	7812.0481	2100	700	900	81	623,-	7812.0379	2100	800	900	84	654,-
7812.0389	2200	600	900	82	603,-	7812.0482	2200	700	900	85	639,-	7812.0493	2200	800	900	88	670,-
7812.0359	2300	600	900	86	618,-	7812.0369	2300	700	900	89	654,-	7812.0380	2300	800	900	92	688,-
7812.0390	2400	600	900	90	631,-	7812.0483	2400	700	900	93	672,-	7812.0381	2400	800	900	96	706,-
7812.0391	2500	600	900	94	646,-	7812.0484	2500	700	900	97	689,-	7812.0494	2500	800	900	100	722,-
7812.0357	2600	600	900	98	660,-	7812.0367	2600	700	900	101	704,-	7812.0382	2600	800	900	104	739,-
7812.0392	2700	600	900	102	676,-	7812.0485	2700	700	900	105	720,-	7812.0383	2700	800	900	108	756,-
7812.0393	2800	600	900	106	691,-	7812.0486	2800	700	900	109	738,-	7812.0384	2800	800	900	112	774,-
7812.0394	2900	600	900	110	705,-	7812.0487	2900	700	900	113	753,-	7812.0385	2900	800	900	116	790,-







ACCESSORIES

	7003.0250			
	H L	400x630x590	KG	128 € 495,-
				
	6x			€ 241,-

WORKTABLE WITH BOTTOM SHELF AND EXTRA SHELF

-  WERKTAFEL BODEMSCHAP EN MIDDENSCHAP
-  ARBEITSTISCH MIT GRUNDBODEN UND MITTELBRETT
-  WORKTABLE WITH BOTTOM SHELF AND EXTRA SHELF
-  PLAN DE TRAVAIL ÉTAGÈRE INFÉRIEUR ET ÉTAGÈRE SUPPLEMENTAIRE







600 LINE						700 LINE						800 LINE					
L	D	H	kg	€		L	D	H	kg	€		L	D	H	kg	€	
																	
7812.0287	700	600	900	35	384,-	7812.0316	700	700	900	37	403,-	7812.0336	700	800	900	42	422,-
7812.0288	800	600	900	39	405,-	7812.0317	800	700	900	41	426,-	7812.0337	800	800	900	43	447,-
7812.0289	900	600	900	41	426,-	7812.0318	900	700	900	43	450,-	7812.0338	900	800	900	78	472,-
7812.0290	1000	600	900	43	446,-	7812.0300	1000	700	900	45	472,-	7812.0320	1000	800	900	47	496,-
7812.0291	1100	600	900	45	475,-	7812.0301	1100	700	900	47	506,-	7812.0321	1100	800	900	49	531,-
7812.0292	1200	600	900	47	495,-	7812.0302	1200	700	900	49	529,-	7812.0322	1200	800	900	51	554,-
7812.0293	1300	600	900	49	518,-	7812.0303	1300	700	900	52	552,-	7812.0323	1300	800	900	53	580,-
7812.0276	1400	600	900	53	537,-	7812.0319	1400	700	900	55	575,-	7812.0339	1400	800	900	57	604,-
7812.0294	1500	600	900	56	558,-	7812.0304	1500	700	900	59	598,-	7812.0324	1500	800	900	62	629,-
7812.0295	1600	600	900	62	580,-	7812.0305	1600	700	900	65	622,-	7812.0325	1600	800	900	68	652,-
7812.0277	1700	600	900	65	599,-	7812.0340	1700	700	900	68	645,-	7812.0343	1700	800	900	71	677,-
7812.0296	1800	600	900	69	621,-	7812.0306	1800	700	900	71	667,-	7812.0326	1800	800	900	74	702,-
7812.0278	1900	600	900	73	642,-	7812.0307	1900	700	900	76	691,-	7812.0327	1900	800	900	79	726,-
7812.0298	2000	600	900	80	661,-	7812.0308	2000	700	900	79	713,-	7812.0328	2000	800	900	82	749,-
																	
7812.0279	2100	600	900	82	776,-	7812.0309	2100	700	900	84	831,-	7812.0329	2100	800	900	86	873,-
7812.0280	2200	600	900	86	797,-	7812.0341	2200	700	900	85	856,-	7812.0344	2200	800	900	94	897,-
7812.0299	2300	600	900	90	819,-	7812.0310	2300	700	900	89	877,-	7812.0330	2300	800	900	98	922,-
7812.0281	2400	600	900	94	838,-	7812.0311	2400	700	900	93	900,-	7812.0331	2400	800	900	102	946,-
7812.0282	2500	600	900	98	859,-	7812.0342	2500	700	900	97	923,-	7812.0345	2500	800	900	106	969,-
7812.0297	2600	600	900	102	880,-	7812.0312	2600	700	900	101	945,-	7812.0332	2600	800	900	110	994,-
7812.0283	2700	600	900	106	900,-	7812.0313	2700	700	900	105	969,-	7812.0333	2700	800	900	114	1018,-
7812.0284	2800	600	900	110	921,-	7812.0314	2800	700	900	109	992,-	7812.0334	2800	800	900	118	1042,-
7812.0285	2900	600	900	114	943,-	7812.0315	2900	700	900	113	1015,-	7812.0335	2900	800	900	122	1066,-

ACCESSORIES



	4x	€ 161,-
	6x	€ 241,-

WORKTABLE BOTTEM SHELF FLAT PACKED

-  WERKTAFEL BODEMSCHAP DEMONTABEL
-  ARBEITSTISCH MIT GRUNDBODEN DEMONTABEL
-  WORKTABLE BOTTEM SHELF FLAT PACKED
-  PLAN DE TRAVAIL ÉTAGÈRE DÉMONTABLE

HEIGHT
600







600 LINE						700 LINE					
L	D	H	kg	€		L	D	H	kg	€	
											
7452.3300	400	600	600	15	223,-	7452.3320	400	700	600	18	229,-
7452.3305	800	600	600	25	232,-	7452.3325	800	700	600	28	244,-
7452.3310	1200	600	600	38	279,-	7452.3330	1200	700	600	45	287,-
7452.3315	1600	600	600	55	340,-	7452.3335	1600	700	600	60	334,-



Cooking range
Drop-in
Ovens
Kitchen equipment
Refrigeration
Dishwashers
Neutral
Faucets
Ventilation
Pizzeria
Bakery





WORKTABLE SLIDING DOORS DRAWERS

-  WERKTAFEL SCHUIFDEUREN LADEN
-  ARBEITSTISCH SCHIEBETÜREN SCHUBLADEN
-  WORKTABLE SLIDING DOORS DRAWERS
-  PLAN DE TRAVAIL PORTES COULISS TIROIRS



	L	D	H	GN	KG	€
7452.0906	1600	700	850 / 900	1/1	97	1.270,-
7452.0908	1800	700	850 / 900	1/1	102	1.325,-
7452.0910	2000	700	850 / 900	1/1	107	1.450,-





WORKTABLE SLIDING DOORS DRAWERS WITH UPSTAND

-  WERKTAFEL SCHUIFDEUREN LADEN MET RAND
-  700 ARBEITSTISCH SCHIEBETÜREN SCHUBLADEN MIT AUFKANTUNG
-  700 WORKTABLE SLIDING DOORS DRAWERS WITH UPSTAND
-  700 PLAN DE TRAVAIL PORTES COULISS TIROIRS AVEC BORD RELEVÉ





	L	D	H	GN	KG	€
7452.0926	1600	700	850 / 900	1/1	97	1.299,-
7452.0928	1800	700	850 / 900	1/1	102	1.390,-
7452.0930	2000	700	850 / 900	1/1	107	1.497,-





WORKTABLE WITH DRAWERS

-  WERKTAFEL MET LADEN
-  ARBEITSTISCH MIT SCHUBLADEN
-  WORKTABLE WITH DRAWERS
-  TABLE DE TRAVAIL AVEC TIROIRS





	7452.0500	7452.0505
	400x700x850	600x700x850
	39	43
€	637,-	707,-





WORKTABLE WITH DRAWERS WITH UPSTAND

-  WERKTAFEL MET LADEN MET OPSTAND
-  ARBEITSTISCH MIT SCHUBLADEN MET AUFKANTUNG
-  WORKTABLE WITH DRAWERS WITH UPSTAND
-  TABLE DE TRAVAIL AVEC TIROIRS AVEC DOSSERET



	7452.0510	7452.0515
	400x700x850	600x700x850
	39	43
€	671,-	740,-

WORKTABLE SLIDING DOORS





-  WERKTAFEL SCHUIFDEUREN
-  ARBEITSTISCH SCHIEBETÜREN
-  WORKTABLE SLIDING DOORS
-  PLAN DE TRAVAIL PORTES COULISSANTES



600 LINE	L	D	H	KG	€
7452.3005	1200	600	850	69	584,-
7452.3010	1600	600	850	78	698,-
7452.3015	2000	600	850	91	856,-

700 LINE	L	D	H	KG	€
7452.3020	800	700	850	69	530,-
7452.3025	1000	700	850	72	544,-
7452.3030	1200	700	850	75	595,-
7452.3035	1400	700	850	79	668,-
7452.3040	1600	700	850	85	744,-
7452.3045	1800	700	850	91	823,-
7452.3050	2000	700	850	95	901,-

WORKTABLE SLIDING DOORS UPSTAND





-  WERKTAFEL SCHUIFDEUREN RAND
-  ARBEITSTISCH SCHIEBETÜREN AUFKANTUNG
-  WORKTABLE SLIDING DOORS UPSTAND
-  PLAN DE TRAVAIL PORTES COULISSANTES BORD RELEVÉ









600 LINE	L	D	H	KG	€
7452.3055	1200	600	850	70	602,-
7452.3060	1600	600	850	83	715,-
7452.3065	2000	600	850	92	868,-

700 LINE	L	D	H	KG	€
7452.3070	800	700	850	70	540,-
7452.3075	1000	700	850	73	558,-
7452.3080	1200	700	850	76	607,-
7452.3085	1400	700	850	80	686,-
7452.3090	1600	700	850	86	766,-
7452.3095	1800	700	850	92	846,-
7452.3100	2000	700	850	96	925,-





WORKTABLE SLIDING DOORS

-  WERKTAFEL SCHUIFDEUREN
-  ARBEITSTISCH SCHIEBETÜREN
-  WORKTABLE SLIDING DOORS
-  PLAN DE TRAVAIL PORTES COULISSANTES







600 LINE	L	D	H	KG	€	700 LINE	L	D	H	KG	€	800 LINE	L	D	H	KG	€
																	
7812.0090	1000	600	900	76	675,-	7812.0103	1000	700	900	82	705,-	7812.0400	1000	800	900	86	739,-
7812.0091	1100	600	900	78	701,-	7812.0104	1100	700	900	83	733,-	7812.0401	1100	800	900	88	770,-
7812.0092	1200	600	900	79	727,-	7812.0105	1200	700	900	85	760,-	7812.0402	1200	800	900	91	799,-
7812.0093	1300	600	900	82	754,-	7812.0106	1300	700	900	86	790,-	7812.0403	1300	800	900	93	829,-
7812.0107	1400	600	900	85	780,-	7812.0107	1400	700	900	85	780,-	7812.0456	1400	800	900	95	858,-
7812.0094	1500	600	900	88	806,-	7812.0115	1500	700	900	92	844,-	7812.0404	1500	800	900	98	886,-
7812.0095	1600	600	900	92	834,-	7812.0120	1600	700	900	95	874,-	7812.0405	1600	800	900	99	917,-
7812.0108	1700	600	900	95	860,-	7812.0118	1700	700	900	99	901,-	7812.0457	1700	800	900	101	945,-
																	
7812.0096	1800	600	900	97	1.013,-	7812.0122	1800	700	900	101	1.055,-	7812.0406	1800	800	900	103	1.107,-
7812.0097	1900	600	900	99	1.039,-	7812.0123	1900	700	900	103	1.080,-	7812.0407	1900	800	900	105	1.134,-
7812.0098	2000	600	900	101	1.065,-	7812.0125	2000	700	900	105	1.065,-	7812.0408	2000	800	900	107	1.169,-
7812.0099	2100	600	900	103	1.090,-	7812.0126	2100	700	900	107	1.090,-	7812.0409	2100	800	900	109	1.196,-
7812.0100	2200	600	900	105	1.114,-	7812.0127	2200	700	900	109	1.140,-	7812.0410	2200	800	900	111	1.224,-
7812.0101	2300	600	900	108	1.140,-	7812.0128	2300	700	900	113	1.192,-	7812.0411	2300	800	900	115	1.251,-
7812.0102	2400	600	900	112	1.165,-	7812.0129	2400	700	900	117	1.219,-	7812.0412	2400	800	900	119	1.280,-
7812.0109	2500	600	900	116	1.189,-	7812.0130	2500	700	900	121	1.245,-	7812.0413	2500	800	900	124	1.307,-
7812.0116	2600	600	900	120	1.214,-	7812.0135	2600	700	900	125	1.271,-	7812.0414	2600	800	900	128	1.334,-
7812.0117	2700	600	900	124	1.239,-	7812.0136	2700	700	900	129	1.298,-	7812.0458	2700	800	900	132	1.364,-
7812.0119	2800	600	900	126	1.265,-	7812.0124	2800	700	900	133	1.324,-	7812.0459	2800	800	900	135	1.391,-
7812.0121	2900	600	900	130	1.290,-	7812.0131	2900	700	900	135	1.351,-	7812.0111	2900	800	900	140	1.419,-

SINK UNIT SHELF



-  SPOELTAFEL BODEMSCHAP
-  SPÜLTISCH GRUNDBODEN
-  SINK UNIT SHELF
-  BLOC-ÉVIER ÉTAGÈRE









SINK UNIT SHELF FLAT PACKED

-  SPOELTAFEL BODEMSCHAP DEMONTABEL
-  SPÜLTISCH GRUNDBODEN DEMONTABEL
-  SINK UNIT SHELF FLAT PACKED
-  BLOC-ÉVIER ÉTAGÈRE DÉMONTABLE







600 LINE				€
7408.0300	1200x600x900	500x400x250	50	535,-
7408.0301	1200x600x900	500x400x250	50	535,-
7408.0314	2000x600x900	500x400x250	83	840,-
7408.0315	2000x600x900	500x400x250	83	840,-







700 LINE				€
7408.0005	700x700x900	500x500x300	40	480,-
7408.0010	1200x700x900	500x500x300	50	580,-
7408.0011	1200x700x900	500x500x300	50	580,-
7408.0015	1400x700x900	600x500x320	57	630,-
7408.0016	1400x700x900	600x500x320	57	630,-
7408.0025	1600x700x900	400x500x250	60	785,-
7408.0026	1600x700x900	400x500x250	60	785,-
7408.0035	2000x700x900	400x500x250	83	915,-
7408.0040	2400x700x900	500x500x300	97	1.030,-











700 LINE				€
7455.0200	700x700x900	500x500x300	40	298,-
7455.0205	1200x700x900	500x500x300	50	390,-
7455.0210	1200x700x900	500x500x300	50	390,-
7455.0215	1800x700x900	500x500x300	65	595,-
7455.0220	1800x700x900	500x500x300	65	595,-
7455.0225	1200x700x900	500x500x300	65	470,-







SINK UNIT SHELF FLAT PACKED

-  SPOELTAFEL BODEMSCHAP DEMONTABEL
-  SPÜLTISCH GRUNDBODEN DEMONTABEL
-  SINK UNIT SHELF FLAT PACKED
-  BLOC-ÉVIER ÉTAGÈRE DÉMONTABLE





600 LINE	L	D	H	LxDxH ^{mm}			€
7452.0400	1200	600	850	500x400x250		41	526,-
7452.0405	1200	600	850	500x400x250		41	526,-
7452.0410	2000	600	900	500x400x250		71	814,-
7452.0415	2000	600	850	500x400x250		55	814,-

700 LINE	L	D	H	LxDxH ^{mm}			€
7452.0420	700	700	850	500x500x300		33	505,-
7452.0425	1200	700	850	500x500x300		54	598,-
7452.0430	1200	700	850	500x500x300		54	598,-
7452.0435	1400	700	850	600x500x300		62	647,-
7452.0440	1400	700	850	600x500x300		62	647,-
7452.0445	1600	700	850	400x500x250		77	830,-
7452.0450	1600	700	850	400x500x250		77	830,-
7452.0455	2000	700	850	400x500x250		82	875,-
7452.0460	2400	700	900	500x500x300		97	1.091,-





SINK UNIT SHELF FLAT PACKED

-  SPOELTAFEL BODEMSCHAP VAATWASSER DEMONTABEL
Tafel links van machine
-  SPÜLTISCH GRUNDBODEN DEMONTABEL
Tisch auf der linken Seite
-  SINK UNIT SHELF FLAT PACKED
Table left side of machine
-  BLOC-ÉVIER ÉTAGÈRE DÉMONTABLE
Table à gauche de machine







700 LINE	L	D	H	LxDxH ^{mm}			€
7452.0465	1200	700	850	400x500x250		54	641,-
7452.0475	1400	700	850	600x500x300		62	691,-

SINK UNIT SHELF FLAT PACKED

-  SPOELTAFEL BODEMSCHAP VAATWASSER DEMONTABEL
Tafel rechts van machine
-  SPÜLTISCH GRUNDBODEN DEMONTABEL
Tisch auf der rechten Seite
-  SINK UNIT SHELF FLAT PACKED
Table right side of machine
-  BLOC-ÉVIER ÉTAGÈRE DÉMONTABLE
Table à droite de machine







700 LINE	L	D	H	LxDxH ^{mm}			€
7452.0470	1200	700	850	400x500x250		54	641,-
7452.0480	1400	700	850	600x500x300		62	691,-



Cooking range
Drop-in
Ovens
Kitchen equipment
Refrigeration
Dishwashers
Neutral
Faucets
Ventilation
Pizzeria
Bakery

SINK UNIT SLIDING DOORS

-  SPOELTAFEL SCHUIFDEUREN
-  SPÜLTISCH SCHIEBETÜREN
-  SINK UNIT SLIDING DOORS
-  BLOC-ÉVIER PORTES COULISSANTES



600 LINE	L	D	H	LxDxH	KG	€	700 LINE	L	D	H	LxDxH	KG	€
7408.0250	1200	600	900	500x400x250	55	805,-	7408.0072	1200	700	900	500x500x300	55	855,-
7408.0251	1200	600	900	500x400x250	55	805,-	7408.0084	1200	700	900	500x500x300	55	855,-
7408.0254	1400	600	900	500x400x250	65	900,-	7408.0074	1400	700	900	600x500x300	65	965,-
7408.0255	1400	600	900	500x400x250	65	900,-	7408.0086	1400	700	900	600x500x300	65	965,-
7408.0258	1600	600	900	500x400x250	75	1.075,-	7408.0078	1600	700	900	400x500x250	75	1.125,-
7408.0259	1600	600	900	400x400x250	75	1.075,-	7408.0088	1600	700	900	400x500x250	75	1.125,-
7408.0264	2000	600	900	500x400x250	93	1.255,-	7408.0080	2000	700	900	400x500x250	93	1.380,-
7408.0265	2000	600	900	500x400x250	93	1.255,-	7408.0081	2000	700	900	600x500x320	93	1.360,-
							7408.0094	2000	700	900	600x500x320	93	1.360,-
							7408.0082	2000	700	900	500x400x300	110	1.570,-

SINK UNIT

-  SPOELTAFEL
-  SPÜLTISCH
-  SINK UNIT
-  BLOC-ÉVIER



600 LINE	L	D	H	LxDxH	KG	€
7808.0550	1200	700	850	1050x550x350	39	815,-
7808.0552	1600	700	850	1450x550x350	51	920,-

SINK UNIT TABLETOP

-  SPOELTAFELBLAD
-  SPÜLTISCHPLATTE
-  SINK UNIT TABLETOP
-  ÉVIER









	L	D	H	LxDxH	KG	€		L	D	H	LxDxH	KG	€
7013.1310	1200	600	40	500x400x250	26	234,-	7013.1140	1400	700	40	600x500x300	32	273,-
7013.1315	1200	600	40	500x400x250	26	234,-	7013.1145	1400	700	40	600x500x300	32	273,-
7013.1400	2000	600	40	500x400x250	44	404,-	7013.1160	1600	700	40	400x500x250	38	368,-
7013.1405	2000	600	40	500x400x250	44	404,-	7013.1165	1600	700	40	400x500x250	38	368,-
7013.1100	700	700	40	500x500x300	18	210,-	7013.1205	2000	700	40	500x500x300	46	437,-
7013.1120	1200	700	40	500x500x300	28	250,-	7013.1210	2400	700	40	500x400x300	54	488,-
7013.1125	1200	700	40	500x500x300	28	250,-							



DISPLAY TABLE FISH

-  DISPLAYTAFEL VIS
-  ANZEIGTISCH FISCH
-  DISPLAY TABLE FISH
-  TABLE D'EXPOSÉ DU POISSON



	L	D	H		€
7812.2015	850	850	920-1275	35	1.106,- 
7812.2020	1100	1100	920-1275	42	1.270,- 
7812.2025	1250	1250	920-1275	50	1.442,- 
7812.2030	1500	1000	920-1275	46	1.410,- 
7812.2035	1500	1250	920-1275	54	1.576,- 
7812.2040	2000	1000	920-1275	57	1.647,- 



















	L	D	H		€
7812.2045	990	1100	920-1275	40	1.381,- 

HEATED CUPBOARD





-  WARMHOUDKAST
-  WÄRMESCHRANK
-  HEATED CUPBOARD
-  ARMOIRE CHAUFFANT











600 LINE	L	D	H				€
7452.0070	1200	600	850	230	2,4	77	1.100,- 
7452.0072	1400	600	850	230	2,4	86	1.150,- 
7452.0074	1600	600	850	230	2,4	90	1.225,- 
7452.0076	1800	600	850	230	2,4	92	1.275,- 
7452.0078	2000	600	850	230	2,4	95	1.325,- 









700 LINE	L	D	H				€
7452.0002	1200	700	850	230	2,4	86	1.195,- 
7452.0004	1400	700	850	230	2,4	95	1.290,- 
7452.0006	1600	700	850	230	2,4	107	1.435,- 
7452.0008	1800	700	850	230	2,4	115	1.455,- 
7452.0010	2000	700	850	230	2,4	128	1.499,- 

HEATED CUPBOARD UPSTAND

-  WARMHOUDKAST RAND
-  WÄRMESCHRANK AUFKANTUNG
-  HEATED CUPBOARD UPSTAND
-  ARMOIRE CHAUFFANT BORD RELEVÉ



600 LINE	L	D	H				€
7452.0082	1200	600	850	230	2,4	77	1.155,- 
7452.0084	1400	600	850	230	2,4	86	1.210,- 
7452.0086	1600	600	850	230	2,4	90	1.285,- 
7452.0088	1800	600	850	230	2,4	92	1.340,- 
7452.0090	2000	600	850	230	2,4	95	1.390,- 

700 LINE	L	D	H				€
7452.0012	1200	700	850	230	2,4	87	1.255,- 
7452.0014	1400	700	850	230	2,4	96	1.350,- 
7452.0016	1600	700	850	230	2,4	108	1.499,- 
7452.0018	1800	700	850	230	2,4	116	1.530,- 
7452.0020	2000	700	850	230	2,4	129	1.570,- 

Cooking range

Drop-in

Ovens

Kitchen equipment

Refrigeration

Dishwashers

Neutral





Faucets

Ventilation

Pizzeria

Bakery

HEATED CUPBOARD PASS-THROUGH





-  DOORGEEF WARMHOUDKAST
-  WÄRMESCHRANK DURCHREICHE
-  HEATED CUPBOARD PASS-THROUGH
-  ARMOIRE CHAUFFANT DOUBLE FACADE



600 LINE	L	D	H	⚡ VOLT	⚡ KW	⚖️ KG	€
7452.0092	1200	600	850	230	2,4	77	1.180,-
7452.0094	1600	600	850	230	2,4	90	1.340,-
7452.0096	2000	600	850	230	2,4	95	1.490,-

700 LINE	L	D	H	⚡ VOLT	⚡ KW	⚖️ KG	€
7452.0022	1200	700	850	230	2,4	93	1.350,-
7452.0024	1400	700	850	230	2,4	104	1.395,-
7452.0026	1600	700	850	230	2,4	114	1.520,-
7452.0028	1800	700	850	230	2,4	123	1.575,-
7452.0030	2000	700	850	230	2,4	135	1.660,-

WALL CUPBOARD SLIDING DOORS

-  WANDKAST SCHUIFDEUREN
-  WANDSCHRANK SCHIEBETÜREN
-  WALL CUPBOARD SLIDING DOORS
-  ARMOIRE MURALE PORTES COULISSIS



	L	D	H	⚖️ KG	€
7452.0054	1000	400	650	27	331,-
7452.0056	1200	400	650	30	368,-
7452.0058	1400	400	650	31	409,-
7452.3230	1600	400	650	33	453,-
7452.0060	1800	400	650	47	502,-
7452.0062	2000	400	650	56	561,-





OVERSHELF 1 LEVEL

-  ETAGERE 1 NIVEAU
-  ETAGERE 1 STUFIG
-  OVERSHELF 1 LEVEL
-  ÉTAGÈRE 1 NIVEAUX



	L	D	H	⚖️ KG	€
7452.0200	1000	300	350	11	130,-
7452.0205	1200	300	350	12	140,-
7452.0210	1400	300	350	13	150,-
7452.0215	1600	300	350	14	160,-
7452.0220	1800	300	350	15	173,-
7452.0225	2000	300	350	17	177,-

OVERSHELF HEATED 1 LEVEL

-  ETAGERE VERWARMD 1 NIVEAU
-  ETAGERE BEHEIZT 1 STUFIG
-  OVERSHELF HEATED 1 LEVEL
-  ÉTAGÈRE CHAUFFÉE 1 NIVEAUX



	L	D	H	⚡ KW	⚡ VOLT	⚖️ KG	€
7452.0260	1000	300	350	1x 0,35	230	11	341,-
7452.0265	1200	300	350	2 x 0,35	230	12	428,-
7452.0270	1400	300	350	2 x 0,35	230	13	461,-
7452.0275	1600	300	350	3 x 0,35	230	14	527,-
7452.0280	1800	300	350	3 x 0,35	230	15	643,-
7452.0285	2000	300	350	3 x 0,35	230	17	666,-





OVERSHELF 2 LEVELS

-  ETAGERE 2 NIVEAUS
-  ETAGERE 2 STUFIG
-  OVERSHELF 2 LEVELS
-  ÉTAGÈRE 2 NIVEAUX



	L	D	H	⚖️ KG	€
7452.0230	1000	300	650	18	243,-
7452.0235	1200	300	650	20	272,-
7452.0240	1400	300	650	22	286,-
7452.0245	1600	300	650	24	297,-
7452.0250	1800	300	650	26	319,-
7452.0255	2000	300	650	28	329,-



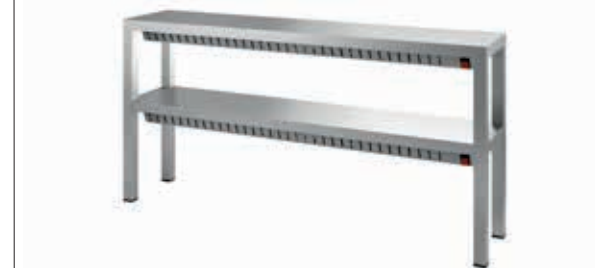

OVERSHELF HEATED 2 LEVELS

-  ETAGERE VERWARMD 2 NIVEAUS
-  ETAGERE BEHEIZT 2 STUFIG
-  OVERSHELF HEATED 2 LEVELS
-  ÉTAGÈRE CHAUFFÉE 2 NIVEAUX



	L	D	H	⚡ KW	⚡ VOLT	⚖️ KG	€
7452.0290	1000	300	650	2 x 0,35	230	14	664,-
7452.0295	1200	300	650	4 x 0,35	230	18	849,-
7452.0320	1400	300	650	4 x 0,35	230	22	920,-
7452.0325	1600	300	650	6 x 0,35	230	26	1.084,-
7452.0330	1800	300	650	6 x 0,35	230	30	1.259,-
7452.0335	2000	300	650	6 x 0,35	230	34	1.310,-





SS PORCELAIN CLOSET

-  RVS SERVIESKAST
-  EDELSTAHL PORZELLANSCHRANK
-  SS PORCELAIN CLOSET
-  ARMOIRE DE PORCELAINE



	L	D	H	LEVELS	KG	€
7452.0064	1200	600	2000	4	144	1.450,-
7452.0066	1600	600	2000	4	192	1.595,-
7452.0068	2000	600	2000	4	240	1.850,-

SS PORCELAIN CLOSET

-  RVS SERVIESKAST
-  EDELSTAHL PORZELLANSCHRANK
-  SS PORCELAIN CLOSET
-  ARMOIRE DE PORCELAINE







PLINTH

-  PLINT
-  WANDPLEISTE
-  PLINTH
-  PLINTHES

	L	D	H	LEVELS	KG	€
7003.0700	680	580	1800	5	80	1.215,-
7003.0701	950	580	1800	5	100	1.570,-
7003.0702	1280	580	1800	5	150	1.930,-
7003.0703	1880	580	1800	5	200	2.650,-

	L	H	KG	€
7003.0710	680	100	10	94,-
7003.0711	950	100	15	108,-
7003.0712	1280	100	20	119,-
7003.0713	1880	100	25	151,-

SHELF UNITS

-  STELLING
-  WANDBRETTTER
-  SHELF UNITS
-  ÉTAGÈRES



	L	D	H	LEVELS	KG	€
7455.0750	900	500	1800	4	22	291,-
7455.0755	1200	500	1800	4	41	347,-
7455.0760	1500	500	1800	4	60	404,-
7455.0765	1800	500	1800	4	87	457,-

SHELF UNITS

-  STELLING
-  WANDBRETTTER
-  SHELF UNITS
-  ÉTAGÈRES



	L	D	H	LEVELS	KG	€
7839.0350	1000	400	1800	5	35	417,-
7839.0360	1500	400	1800	5	59	512,-
7839.0370	2000	400	1800	5	83	609,-
7839.0380	2500	400	1800	5	107	764,-





SHELF UNITS

-  STELLING
-  WANDBRETTTER
-  SHELF UNITS
-  ÉTAGÈRES



	L	D	H	LEVELS	KG	€
7839.0300	1000	400	1800	4	35	342,-
7839.0310	1500	400	1800	4	59	420,-
7839.0320	2000	400	1800	4	83	499,-
7839.0330	2500	400	1800	4	107	626,-





SHELVING SYSTEM

-  REKWERK
-  REGALSYSTEM
-  SHELVING SYSTEM
-  SYSTÈME DE RAYONNAGE



	L	D	H	kg	€
7013.2110	775	450	1700	10	246,-
7013.2115	925	450	1700	15	270,-
7013.2120	1075	450	1700	17	290,-
7013.2125	1225	450	1700	20	306,-
7013.2130	1375	450	1700	22	318,-
7013.2135	1525	450	1700	25	346,-
7013.2140	1675	450	1700	27	366,-
7013.2145	1825	450	1700	30	382,-
7013.2150	1975	450	1700	32	402,-





SHELVING SYSTEM STEEL WIRE

-  REKWERK DRAADSTELLING
-  REGALSYSTEM STAHLDRAHT
-  SHELVING SYSTEM STEEL WIRE
-  ETAGERE EN FIL D'ACIER



	L	D	H	LEVELS	kg	€
7013.2200	1220	455	1800	4	24	170,-
7013.2205	1525	455	1800	4	30	200,-
7013.2210	1825	455	1800	4	35	228,-





MICROWAVE SHELF

-  MAGNETRONSCHAP
-  MIKROWELLE WANDREGAL
-  MICROWAVE SHELF
-  ÉTAGÈRE POUR MICRO-ONDE



	L	D	H	kg	€
7003.0780	400	500	350	8	322,-
7003.0781	500	500	350	8	357,-
7003.0782	600	500	350	9	391,-

STAND FOR OVEN

-  ONDERSTEL VOOR OFEN
-  UNTERGESTELL FÜR OFEN
-  STAND FOR OVEN
-  SUPPORT POUR FOUR







	L	D	H	GN	€
7812.2005	900	800	700	8 x 1/1	499,-
7812.2010	900	800	900	8 x 1/1	505,-

ACCESSORIES

	4x	€ 161,-
---	----	---------





CLEARING TROLLEY FLAT-PACKED 1/1GN

-  REGAALWAGEN DEMONTABEL 1/1GN
-  ABRÄUMWAGEN DEMONTABEL 1/1GN
-  CLEARING TROLLEY FLAT-PACKED 1/1GN
-  CHARIOTS DE DÉBRASSAGE DÉMONTABLE 1/1GN







	7455.1070
H L	445x595x1735
GN	15 x 1/1
KG	39
€	225,- 

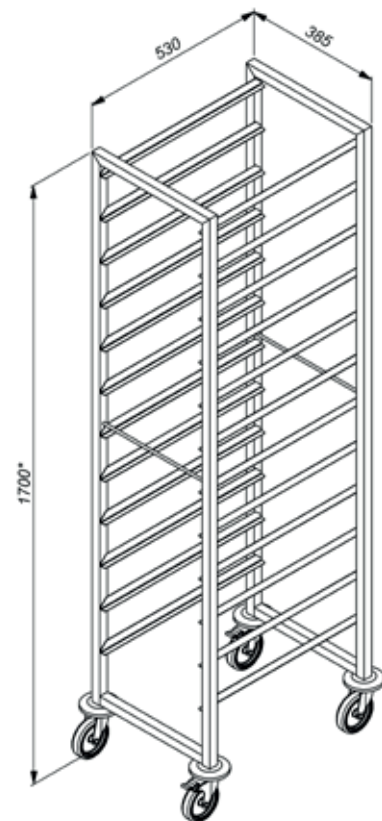



CLEARING TROLLEYS 1/1GN

-  REGAALWAGEN 1/1GN
-  ABRÄUMWAGEN 1/1GN
-  CLEARING TROLLEYS 1/1GN
-  CHARIOTS DE DÉBRASSAGE 1/1GN







	L	D	H	GN	H LEVELS	KG	€
7819.0006	385	530	1700	12x 1/1	123	24	343,- 
7819.0008	385	530	1700	14x 1/1	106	26	367,- 
7819.0010	385	530	1700	16x 1/1	92	28	390,- 
7819.0012	385	530	1700	18x 1/1	82	30	414,- 
7819.0014	385	530	1700	20x 1/1	74	30	438,- 

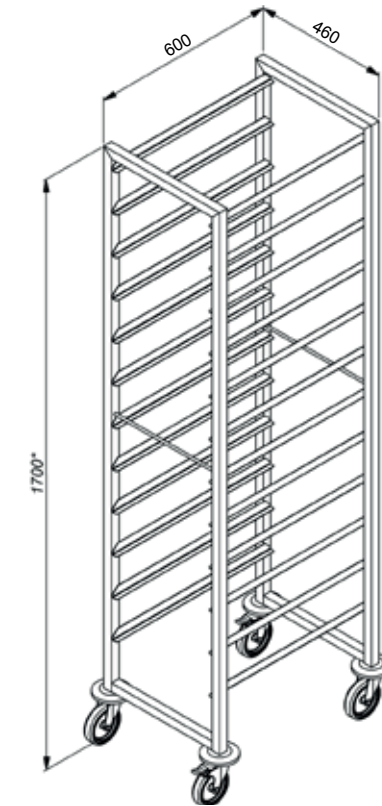



CLEARING TROLLEY 600X400

-  REGAALWAGEN EN 600x400
-  ABRÄUMWAGEN EN 600x400
-  CLEARING TROLLEY 600x400
-  CHARIOTS DÉBRASSAGE EN 600x400





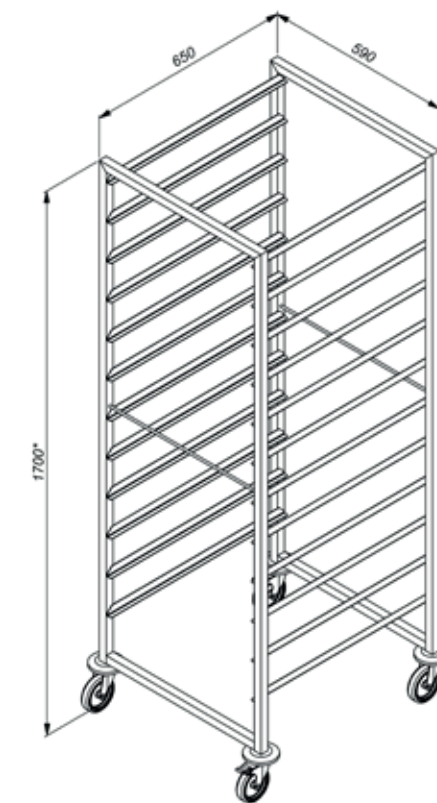

	L	D	H	EN	KG	€
7819.0030	460	600	1700	12	27	343,- 
7819.0032	460	650	1700	14	27	367,- 
7819.0034	460	650	1700	16	30	390,- 
7819.0036	460	600	1700	18	36	414,- 
7819.0038	460	600	1700	20	39	438,- 

CLEARING TROLLEYS 2/1GN

-  REGAALWAGEN 2/1GN
-  ABRÄUMWAGEN 2/1GN
-  CLEARING TROLLEYS 2/1GN
-  CHARIOTS DÉBRASSAGE 2/1GN



	L	D	H	GN	KG	€
7819.0020	590	650	1700	12x 2/1	27	343,- 
7819.0022	590	650	1700	14x 2/1	27	367,- 
7819.0024	590	650	1700	16x 2/1	30	390,- 
7819.0026	590	650	1700	18x 2/1	36	414,- 
7819.0028	590	650	1700	20x 2/1	39	438,- 

Cooking range

Drop-in

Ovens

Kitchen equipment

Refrigeration

Dishwashers

Neutral





Faucets

Ventilation

Pizzeria

Bakery

THERMO TRANSPORTBOX

-  THERMO TRANSPORTBOX
-  THERMO FRONTLADER
-  THERMO TRANSPORTBOX
-  CONTENEUR ISOTHERME





1/1 GN PAN IN TRANSPORTBOX

H	6,5 cm	6 x
H	10 cm	4 x
H	15 cm	3 x
H	20 cm	2 x

TEMPERATURE IN TRANSPORTBOX

	1 HOUR	2 HOURS	3 HOURS	4 HOURS
HOT	75 °C	72 °C	70 °C	68 °C
COLD	2 °C	4 °C	5 °C	6 °C

	7455.0050
	477x680x1420
	40
	€ 599,- 





SERVING TROLLEY

-  SERVEERWAGEN
-  SERVIERWAGEN
-  SERVING TROLLEY
-  CHARIOT DE SERVICE









	7455.0055
	1280x500x960
	3
	15
	€ 105,- 



WASTE BIN FOR SERVING TROLLEY

-  VUILNISBAK VOOR SERVEERWAGEN
-  MÜLLEIMER FÜR SERVIERWAGEN
-  WASTE BIN FOR SERVING TROLLEY
-  POUBELLE POUR CHARIOT DE SERVICE



	7455.0060	7455.0065
	335x231x180	335x231x445
	7455.0055	7455.0055
	1	1
	€ 9,- 	€ 15,- 

SERVING TROLLEY FLAT-PACKED

-  SERVEERWAGEN DEMONTABEL
-  SERVIERWAGEN DEMONTABEL
-  SERVING TROLLEY FLAT-PACKED
-  CHARIOT DE SERVICE DEMONTABLE







	7455.1150
	860x540x940
	830x510
	2x
	14
	€ 112,- 



	7455.1155
	860x540x940
	830x510
	3x
	15
	€ 128,- 









SS WALL SHELVES

-  RVS WANDSCHAP
-  RFS WANDBORDE
-  SS WALL SHELVES
-  ÉTAGÈRE MURALES EN INOX

BUDGET LINE





	L	D	H	KG	€	
7455.0500	1000	300	36	1	44,-	
7455.0505	1200	300	36	1	49,-	
7455.0510	1500	300	36	2	63,-	
7455.0515	1800	300	36	2	77,-	
7455.0520	2000	300	36	3	83,-	
7455.0525	2200	300	36	3	89,-	
7455.0530	2400	300	36	3	96,-	

MOUNTING STRIP 360

-  MONTAGE STRIP 360
-  MONTAGESTREIFEN 360
-  MOUNTING STRIP 360
-  BANDE DE MONTAGE 360

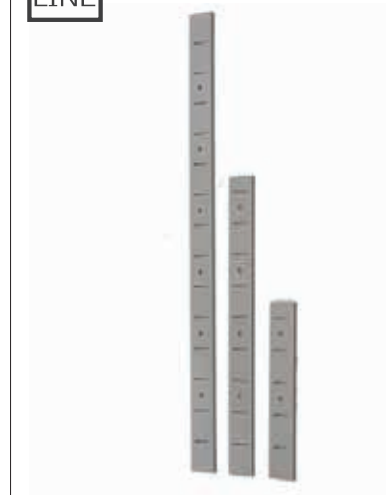
BUDGET LINE





	7455.0540
	
H	360
KG	1
€	12,- 

MOUNTING STRIP 700

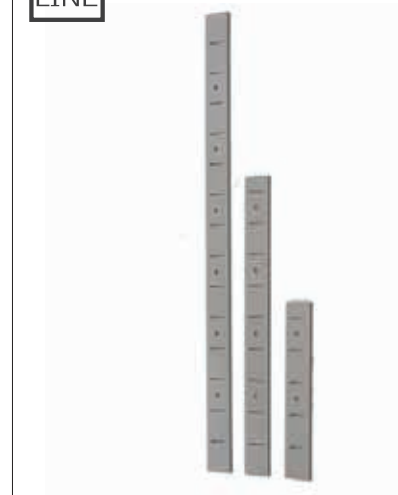

-  MONTAGE STRIP 700
-  MONTAGESTREIFEN 700
-  MOUNTING STRIP 700
-  BANDE DE MONTAGE 700

BUDGET LINE





	7455.0545
	
H	700
KG	1
€	17,- 

MOUNTING STRIP 1000

-  MONTAGE STRIP 1000
-  MONTAGESTREIFEN 1000
-  MOUNTING STRIP 1000
-  BANDE DE MONTAGE 1000

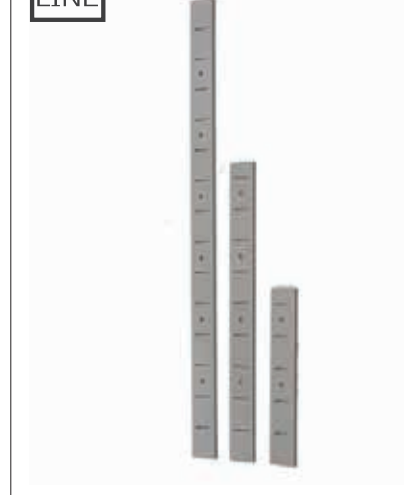
BUDGET LINE



	7455.0550
	
H	1000
KG	1
€	22,- 

ADJUSTABLE BRACKET





-  REGELBARE KONSOLE
-  REGELBARE KONSOLE
-  ADJUSTABLE BRACKET
-  CONSOLE RÉGLABLE

BUDGET LINE



	7455.0555
	
KG	2
€	18,- 

PERMANENT BRACKET SINGLE





-  VASTE KONSOLE ENKEL
-  FESTE KONSOLE EINZEL
-  PERMANENT BRACKET SINGLE
-  CONSOLE FIXE SEULE

BUDGET LINE



























	7455.0560
	
KG	2
€	16,- 

SS WALL SHELF





-  RVS WANDSCHAP
-  EDELSTAHL WANDBORDE
-  SS WALL SHELF
-  ÉTAGÈRE MURALES EN INOX



	L	D	H	KG	€	
7412.0697	700	300	35	4	59,-	
7412.0698	800	300	35	4	63,-	
7412.0699	900	300	35	4	67,-	
7412.0700	1000	300	35	4	71,-	
7412.0701	1100	300	35	4	75,-	
7412.0705	1200	300	35	4	79,-	
7412.0706	1300	300	35	4	85,-	
7412.0710	1400	300	35	4	89,-	
7412.0711	1500	300	35	5	92,-	
7412.0715	1600	300	35	5	97,-	
7412.0716	1700	300	35	5	101,-	
7412.0720	1800	300	35	6	105,-	
7412.0721	1900	300	35	6	110,-	
7412.0725	2000	300	35	6	114,-	
7412.0717	2100	300	35	7	118,-	
7412.0718	2200	300	35	7	122,-	
7412.0719	2300	300	35	7	126,-	
7412.0722	2400	300	35	8	130,-	
7412.0723	2500	300	35	8	134,-	
7412.0724	2600	300	35	8	137,-	
7412.0726	2700	300	35	9	141,-	
7412.0727	2800	300	35	9	145,-	
7412.0728	2900	300	35	9	149,-	

	L	D	H	KG	€	
7412.1697	700	400	35	4	88,-	
7412.1698	800	400	35	4	94,-	
7412.1699	900	400	35	4	99,-	
7412.1700	1000	400	35	4	104,-	
7412.1701	1100	400	35	4	109,-	
7412.1705	1200	400	35	4	113,-	
7412.1706	1300	400	35	4	122,-	
7412.1710	1400	400	35	4	127,-	
7412.1711	1500	400	35	5	131,-	
7412.1715	1600	400	35	5	138,-	
7412.1716	1700	400	35	5	143,-	
7412.1720	1800	400	35	6	148,-	
7412.1721	1900	400	35	6	155,-	
7412.1725	2000	400	35	6	160,-	
7412.1717	2100	400	35	7	165,-	
7412.1718	2200	400	35	7	170,-	
7412.1719	2300	400	35	7	176,-	
7412.1722	2400	400	35	8	181,-	
7412.1723	2500	400	35	8	186,-	
7412.1724	2600	400	35	8	190,-	
7412.1726	2700	400	35	9	195,-	
7412.1727	2800	400	35	9	200,-	
7412.1728	2900	400	35	9	205,-	





PERMANENT BARCKET SINGLE 300

-  VASTE KONSOLE ENKEL 300
-  FESTE KONSOLE EINZEL 300
-  PERMANENT BARCKET SINGLE 300
-  CONSOLE FIXE SEULE 300



	7412.0730	
	 2	
	€ 21,-	





PERMANENT BRACKET SINGLE 400

-  VASTE KONSOLE ENKEL 400
-  FESTE KONSOLE EINZEL 400
-  PERMANENT BRACKET SINGLE 400
-  CONSOLE FIXE SEULE 400



	7412.1730	
	 2	
	€ 28,-	





PERMANENT BRACKET SINGLE 300

-  VASTE KONSOLE ENKEL 300
-  FESTE KONSOLE EINZEL 300
-  PERMANENT BRACKET SINGLE 300
-  CONSOLE FIXE SEULE 300



	7412.0735	
	 2	
	€ 21,-	





PERMANENT BRACKET 400

-  VASTE KONSOLE ZONDER BUISFRAME 400
-  FESTE KONSOLE OHNE ROHRGESTELL 400
-  PERMANENT BRACKET WITHOUT TUBE FRAME 400
-  CONSOLE FIXE SANS CADRE DE TUBE 400



	7412.1735	
	 2	
	€ 28,-	





PERMANENT BRACKET DOUBLE 300

-  VASTE KONSOLE DUBBEL 300
-  FESTE KONSOLE DOPPELT 300
-  PERMANENT BRACKET DOUBLE 300
-  CONSOLE FIXE DOUBLE 300





	7412.0731	
	 2	
	€ 31,-	





PERMANENT BRACKET DOUBLE 400

-  VASTE KONSOLE DUBBEL 400
-  FESTE KONSOLE DOPPELT 400
-  PERMANENT BRACKET DOUBLE 400
-  CONSOLE FIXE DOUBLE 400



	7412.1731	
	 2	
	€ 40,-	





SS FLAT WORKTOP

-  RVS WERKBLAD
-  EDELSTAHL ARBEITSPLATTE
-  SS FLAT WORKTOP
-  PLAN DE TRAVAIL EN INOX



	L	D	H	KG	€		L	D	H	KG	€		L	D	H	KG	€
7812.0547	700	600	40	14	140,-	7812.0497	700	700	40	16	150,-	7812.0544	700	800	40	18	158,-
7812.0548	800	600	40	16	150,-	7812.0498	800	700	40	18	159,-	7812.0545	800	800	40	20	166,-
7812.0511	900	600	40	18	159,-	7812.0499	900	700	40	20	168,-	7812.0546	900	800	40	22	176,-
7812.0512	1000	600	40	20	167,-	7812.0500	1000	700	40	22	178,-	7812.0524	1000	800	40	24	187,-
7812.0513	1100	600	40	22	175,-	7812.0501	1100	700	40	24	186,-	7812.0525	1100	800	40	26	196,-
7812.0514	1200	600	40	24	184,-	7812.0502	1200	700	40	26	197,-	7812.0526	1200	800	40	28	207,-
7812.0515	1300	600	40	26	192,-	7812.0503	1300	700	40	28	208,-	7812.0527	1300	800	40	30	217,-
7812.0516	1400	600	40	28	201,-	7812.0504	1400	700	40	30	217,-	7812.0528	1400	800	40	32	229,-
7812.0517	1500	600	40	30	210,-	7812.0505	1500	700	40	32	227,-	7812.0529	1500	800	40	34	237,-
7812.0518	1600	600	40	32	219,-	7812.0506	1600	700	40	34	236,-	7812.0530	1600	800	40	36	247,-
7812.0519	1700	600	40	34	228,-	7812.0507	1700	700	40	36	246,-	7812.0531	1700	800	40	38	258,-
7812.0520	1800	600	40	36	236,-	7812.0508	1800	700	40	38	254,-	7812.0532	1800	800	40	40	268,-
7812.0521	1900	600	40	38	246,-	7812.0509	1900	700	40	40	266,-	7812.0533	1900	800	40	42	278,-
7812.0522	2000	600	40	40	254,-	7812.0510	2000	700	40	42	276,-	7812.0534	2000	800	40	44	289,-
7812.0523	2100	600	40	42	265,-	7812.0566	2100	700	40	44	285,-	7812.0535	2100	800	40	46	299,-
7812.0549	2200	600	40	44	273,-	7812.0557	2200	700	40	46	294,-	7812.0536	2200	800	40	48	308,-
7812.0550	2300	600	40	46	282,-	7812.0558	2300	700	40	48	304,-	7812.0537	2300	800	40	50	319,-
7812.0551	2400	600	40	48	290,-	7812.0560	2400	700	40	50	314,-	7812.0538	2400	800	40	52	330,-
7812.0552	2500	600	40	50	298,-	7812.0561	2500	700	40	50	325,-	7812.0539	2500	800	40	54	340,-
7812.0553	2600	600	40	52	307,-	7812.0562	2600	700	40	52	334,-	7812.0540	2600	800	40	56	350,-
7812.0554	2700	600	40	54	315,-	7812.0563	2700	700	40	54	344,-	7812.0541	2700	800	40	56	360,-
7812.0555	2800	600	40	56	325,-	7812.0564	2800	700	40	56	353,-	7812.0542	2800	800	40	60	370,-
7812.0556	2900	600	40	58	334,-	7812.0565	2900	700	40	58	362,-	7812.0543	2900	800	40	62	380,-



30/30 SS CONSOLE

-  30/30 RVS CONSOLE
-  30/30 EDELSTAHL KONSOLE
-  30/30 SS CONSOLE
-  30/30 CONSOLE EN INOX



	L	D	KG	€
7003.0600	225	225	0.2	47,-
7003.0605	275	275	0.4	47,-
7003.0607	325	325	0.6	49,-
7003.0609	375	375	0.7	53,-

40/40 SS CONSOLE

-  40/40 RVS CONSOLE
-  40/40 EDELSTAHL KONSOLE
-  40/40 SS CONSOLE
-  40/40 CONSOLE EN INOX



	L	D	KG	€
7003.0611	425	425	0.8	56,-
7003.0613	475	475	0.9	58,-
7003.0615	575	575	1	60,-
7003.0617	675	675	1.1	63,-
7003.0619	775	775	1.2	65,-

SS TUBE SHELF

-  RVS SPIJLENROOSTER
-  EDELSTAHL GITTERROST
-  SS TUBE SHELF
-  GRIL DE BARRE EN INOX



	L	D	H	KG	€
7419.0300	1000	300	20	6	281,-
7419.0301	1100	300	20	6	290,-
7419.0302	1200	300	20	7	297,-
7419.0303	1300	300	20	7	306,-
7419.0304	1400	300	20	7	313,-
7419.0306	1600	300	20	9	330,-
7419.0307	1700	300	20	9	355,-
7419.0308	1800	300	20	11	363,-
7419.0309	1900	300	20	11	372,-
7419.0310	2000	300	20	11	379,-

	L	D	H	KG	€
7419.0311	2100	300	20	12	387,-
7419.0312	2200	300	20	12	395,-
7419.0313	2300	300	20	12	403,-
7419.0314	2400	300	20	13	411,-
7419.0315	2500	300	20	13	419,-
7419.0316	2600	300	20	13	427,-
7419.0317	2700	300	20	13	436,-
7419.0318	2800	300	20	14	443,-
7419.0319	2900	300	20	14	452,-

WASTE BIN

-  AFVALBAK
-  MÜLLEIMER
-  WASTE BIN
-  POUBELLE





	7013.0755
	Ø 450x685
	95
	18
€	259,-





WASTE BIN

-  AFVALBAK
-  MÜLLEIMER
-  WASTE BIN
-  POUBELLE





	7013.0750
	Ø 450x685
	95
	18
€	225,-





WASTE BIN WITH FOOT PEDAL

-  AFVALBAK VOETPEDAAL
-  MÜLLEIMER MIT FÜßPEDAL
-  WASTE BIN WITH FOOT PEDAL
-  POUBELLE AVEC PÉDALE



	7020.0170	7020.0175
	394x365x910	370x400x800
	90	60
	24	19
€	545,-	515,-





SS CHIPS SCUTTLE

-  RVS FRIETBAK
-  EDELSTAHL POMMES FRITESBEHÄLTER
-  SS CHIPS SCUTTLE
-  RESERVE À FRITES EN INOX



	L	D	H	KG	€
7419.0150	600	300	200	3	224,-
7419.0155	700	300	200	3	245,-
7419.0160	800	300	200	5	268,-
7419.0165	900	300	200	5	290,-
7419.0170	1000	300	200	7	313,-
7419.0175	1100	300	200	7	336,-
7419.0180	1200	300	200	9	358,-
7419.0185	1300	300	200	9	378,-
7419.0190	1400	300	200	11	404,-
7419.0195	1500	300	200	11	424,-





HAND WASHBASIN

-  HANDENWASBAK
-  HANDWASCHBECKEN
-  HAND WASHBASIN
-  LAVABO MAINS







	7013.0785	
	 H	300x315
	 KG	7
	€	179,- 





HAND WASHBASIN

-  HANDENWASBAK
-  HANDWASCHBECKEN
-  HAND WASHBASIN
-  LAVABO MAINS



	7013.0780	
	 H	500x400x850
	 KG	50
	€	499,- 





HAND WASHBASIN

-  HANDENWASBAK
-  HANDWASCHBECKEN
-  HAND WASHBASIN
-  LAVABO MAINS







	7013.0775	
	 H	400x400
	 KG	4
	€	239,- 

HAND WASHBASIN

-  HANDENWASBAK
-  HANDWASCHBECKEN
-  HAND WASHBASIN
-  LAVABO MAINS



	7013.0765	
	 H	500x700x850/450
	 KG	50
	€	549,- 





GN CONTAINER

-  GN PAN
-  GN BEHÄLTER
-  GN CONTAINER
-  GN RÉCIPIENT









	L	D	H	GN	 / KG	€	
7476.0050	530	325	20	1/1	1	12,-	
7476.0055	530	325	40	1/1	1	14,-	
7476.0060	530	325	65	1/1	1	15,-	
7476.0160	530	325	100	1/1	1	16,-	
7476.0065	530	325	150	1/1	1	17,-	
7476.0165	325	265	65	1/2	1	9,-	
7476.0170	325	265	100	1/2	1	13,-	
7476.0070	325	265	150	1/2	1	17,-	
7476.0175	325	176	65	1/3	1	8,-	
7476.0180	325	176	100	1/3	1	10,-	
7476.0075	325	176	150	1/3	1	15,-	
7476.0185	265	162	65	1/4	1	7,-	
7476.0190	265	162	100	1/4	1	9,-	
7476.0080	265	162	150	1/4	1	13,-	
7476.0195	176	162	65	1/6	1	6,-	
7476.0200	176	162	100	1/6	1	8,-	
7476.0085	176	162	150	1/6	1	10,-	
7476.0090	176	108	100	1/9	1	8,-	

GN CONTAINER PERFORATED

-  GN PAN GEPERFOREERD
-  GN BEHÄLTER PERFORIERT
-  GN CONTAINER PERFORATED
-  GN RÉCIPIENT PERFORÉ











	L	D	H	GN	 / KG	€	
7476.0205	530	325	65	1/1	65	17,-	
7476.0210	530	325	150	1/1	150	21,-	
7476.0215	325	265	65	1/2	65	15,-	
7476.0220	325	265	150	1/2	150	19,-	

GN BAR

-  GN STEG
-  GN STEGE
-  GN BAR
-  GN BARRE



	 H	GN	 / KG	€	
7216.1150	20	1/1	1	14,-	
7216.1151	20	1/2	1	12,-	
7216.1152	20	1/3	1	12,-	
7216.1153	20	1/4	1	10,-	
7216.1154	20	1/6	1	7,-	

GN LID

-  GN DEKSEL
-  GN DECKEL
-  GN LID
-  GN COUVRIR



	GN	 / KG	€	
7476.0100	1/1	1	12,-	
7476.0105	1/2	1	8,-	
7476.0110	1/3	1	6,-	
7476.0115	1/4	1	5,-	
7476.0120	1/6	1	5,-	
7476.0125	1/9	1	4,-	



Kranen
Kräne
Faucets
Robinets



FAUCET SINGLE HOLE

- MENG ZWENKKRAAN 1 GATS
- MISCH AUSLEGERZAPFEN 1 LOCH
- FAUCET SINGLE HOLE
- MÉLANGEUR POTENCE 1 TROU



7013.1605
3/4
2
€ 71,-

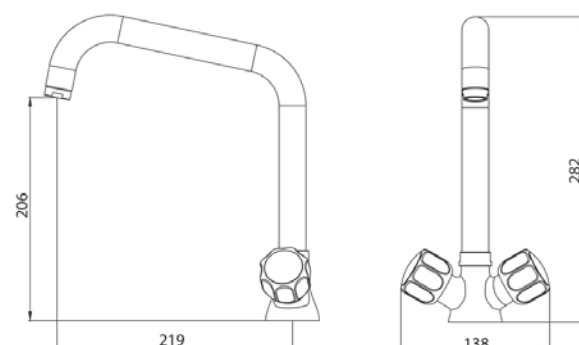

FAUCET SINGLE HOLE

- MENG ZWENKKRAAN 1 GATS
- MISCH AUSLEGERZAPFEN 1 LOCH
- FAUCET SINGLE HOLE
- MÉLANGEUR POTENCE 1 TROU



7212.0010
3/4
1,6
€ 83,-

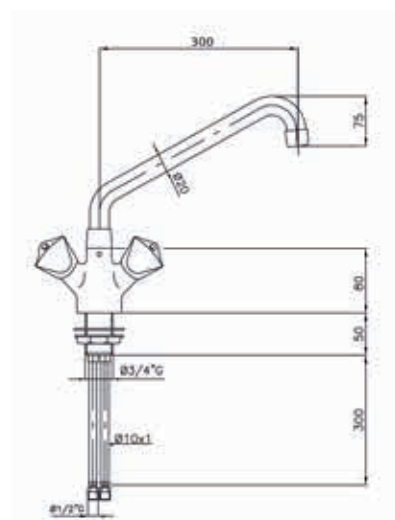

FAUCET WITH ELBOW COMMAND

- KRAAN MET ELLEBOOGBEDIENING
- ZAPFEN MIT ELLEBOGENBEDIENUNG
- FAUCET WITH ELBOW COMMAND
- ROBINET AVEC COMMANDE DE COUDE



7212.0015
1/2
1,4
€ 100,-

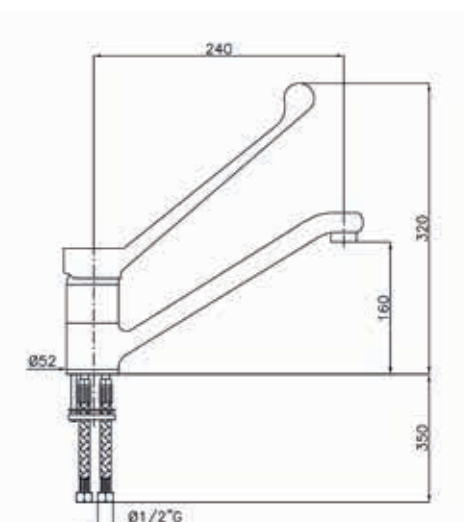

FAUCET DOUBLE PILLAR

- MENGKRAAN 2 GATS
- MISCHZAPFEN 2 LÖCHER
- FAUCET DOUBLE PILLAR
- MÉLANGEUR 2 TROUS



7212.0020
1/2
2,8
€ 130,-

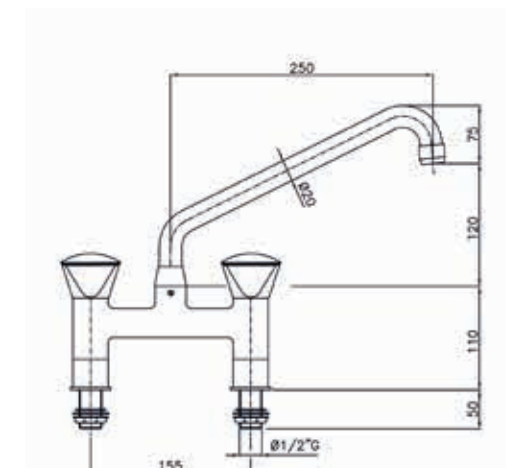

FAUCET WALL-MOUNTED

- MENG ZWENKKRAAN WANDMODEL
- WANDMISCHENZAPFEN
- FAUCET WALL-MOUNTED
- MÉLANGEUR MURALE



7212.0025
1/2
2,3
€ 152,-

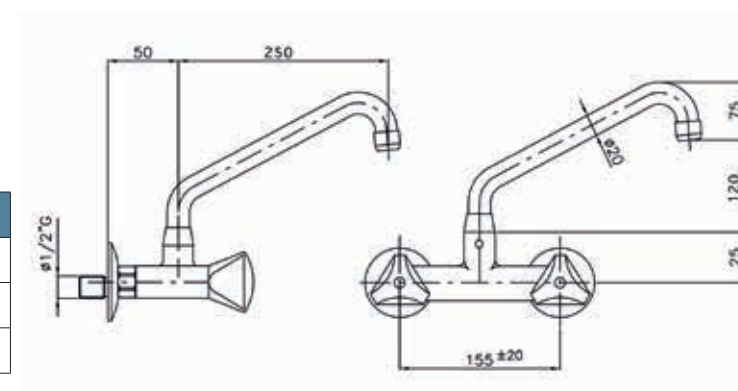

Cooking range

Drop-in

Ovens

Kitchen equipment

Refrigeration

Dishwashers

Neutral

Faucets

Ventilation

Pizzeria

Bakery



PRE RINSE UNIT

- SPOELDOUCHE
- VORSPÜLDUSCHE
- PRE RINSE UNIT
- PRÉ DOUCHE DE RINÇAGE

	7212.0030
	3/4
	6,5
	€ 265,-

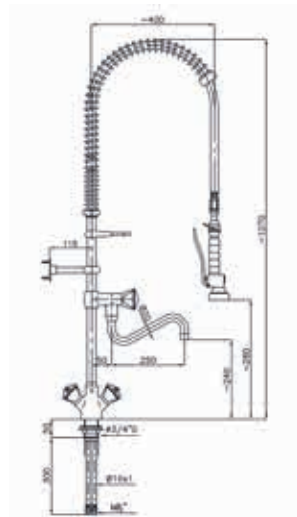

PRE RINSE UNIT ELBOW COMMAND

- SPOELDOUCHE ELLEBOOGBEDIENING
- VORSPÜLDUSCHE ELLEBOGENBEDIENUNG
- PRE RINSE UNIT ELBOW COMMAND
- PRÉ DOUCHE DE RINÇAGE

	7212.0035
	3/4
	7,5
	€ 438,-

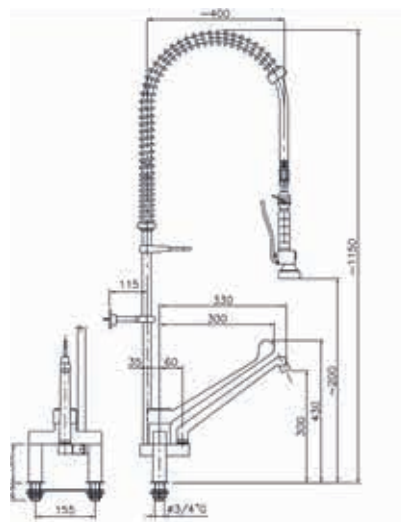

PRE RINSE UNIT WALL MOUNTED

- SPOELDOUCHE WANDMODEL
- WANDSPÜLDUSCHE
- PRE RINSE UNIT WALL MOUNTED
- PRÉ DOUCHE DE RINÇAGE MURALE

	7212.0040
	1/2
	7,1
	€ 428,-

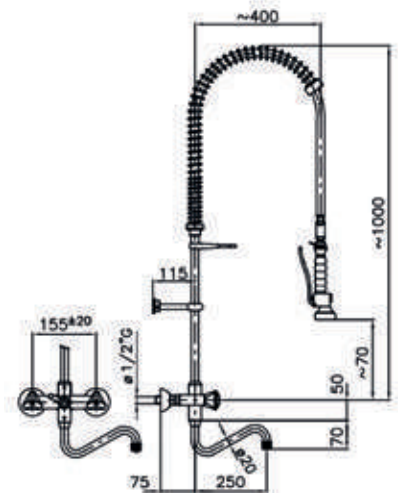

RETRACTABLE HOSE REEL 6 M WITH SPRAY GUN

- SLANGHASPEL 6 M MET SPUITPISTOOL
- SCHLAUCHHASPEL 6 M MIT SPRITZPISTOLE
- RETRACTABLE HOSE REEL 6 M WITH SPRAY GUN
- TREUIL DE TUYAU 6 M AVEC PISTOLET D'EAU

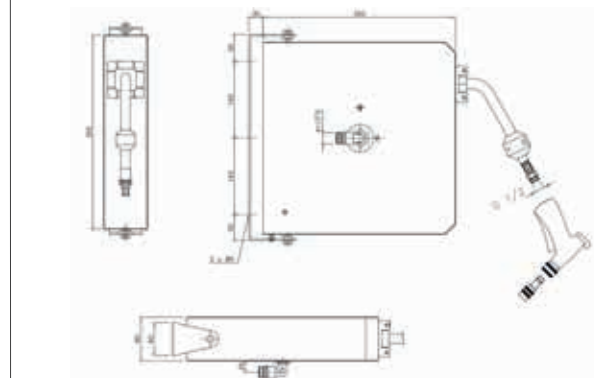

	7212.0045
	12
	€ 766,-

RETRACTABLE HOSE REEL 10 M WITH SPRAY GUN

- SLANGHASPEL 10 M MET SPUITPISTOOL
- SCHLAUCHHASPEL 10 M MIT SPRITZPISTOLE
- RETRACTABLE HOSE REEL 10 M WITH SPRAY GUN
- TREUIL DE TUYAU 10 M AVEC PISTOLET D'EAU

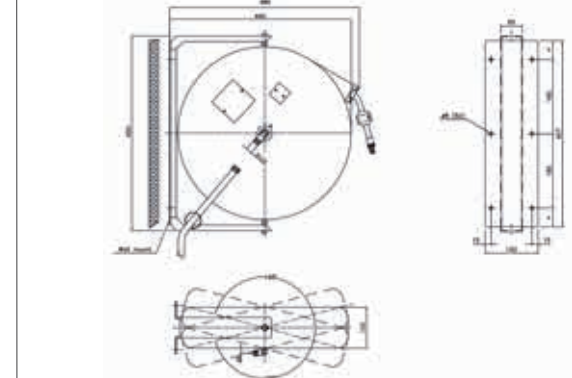

	7212.0050
	16
	€ 1.147,-

PEDAL CONTROLLED MIXING FAUCET 1 PEDAL

- VOETBEDIENING INDIRECT 1 PEDAAL
- MISCHZAPFEN MIT FUBBEDIENUNG 1 PEDAL
- PEDAL CONTROLLED MIXING FAUCET 1 PEDAL
- MÉLANGEUR AVEC COMMANDE DE PIED 1 PÉDALE

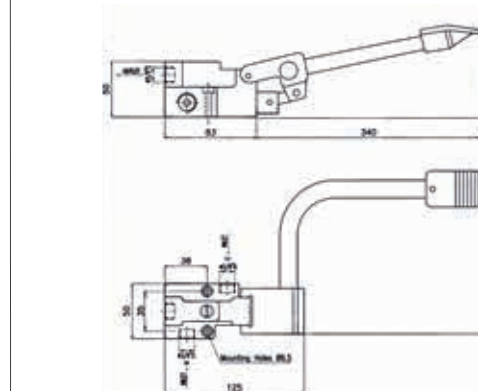

	7212.0055
	1,4
	€ 130,-

PEDAL CONTROLLED MIXING FAUCET 2 PEDALS

- VOETBEDIENING INDIRECT 2 PEDALEN
- MISCHZAPFEN MIT FUBBEDIENUNG 2 PEDALE
- PEDAL CONTROLLED MIXING FAUCET 2 PEDALS
- MÉLANGEUR AVEC COMMANDE DE PIED 2 PÉDALES

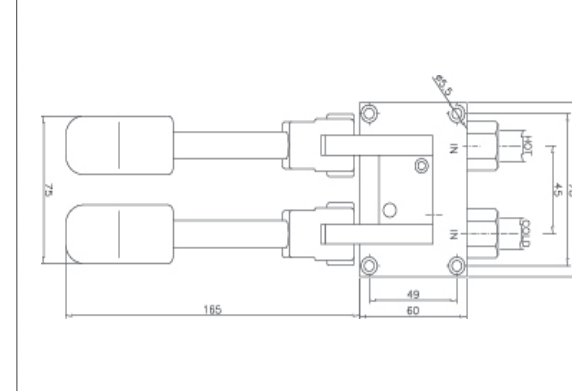

	7212.0060
	1,4
	€ 172,-

Cooking range

Drop-in

Ovens

Kitchen equipment

Refrigeration

Dishwashers

Neutral

Faucets

Ventilation

Pizzeria

Bakery



Afzuiging
Ventilation
Ventilation
Ventilation



WALL-MOUNTED HOOD BOX MODEL

- WANDKAP DOOSMODEL
- WANDHAUBEN DOSEMODELL
- WALL-MOUNTED HOOD BOX MODEL
- HOTTES MURALES MODÈLE DE BOÎTE



	L	D	H	FILTERS	💡	🕒	🔧	🌀	📦 /KG	€	🚚
7411.1850	1500	1000	400	2	X	X	X	X	33	702,-	🚚
7411.1851	2000	1000	400	3	X	X	X	X	44	806,-	🚚
7411.1852	2500	1000	400	4	X	X	X	X	56	968,-	🚚
7411.1853	3000	1000	400	5	X	X	X	X	68	1.146,-	🚚

EXPORT OP AANVRAAG

EXPORT ON REQUEST

EXPORT AUF ANFRAGE

EXPORT SUR DEMANDE

7411.1854	3500	1000	400	6	X	X	X	X	79	1.294,-	🚚
7411.1855	4000	1000	400	6	X	X	X	X	90	1.406,-	🚚

WALL-MOUNTED HOOD BOX MODEL

- WANDKAP DOOSMODEL
- WANDHAUBEN DOSENMODELL
- WALL-MOUNTED HOOD BOX MODEL
- HOTTES MURALES MODÈLE DE BOÎTE



	L	D	H	FILTERS	💡	🕒	🔧	🌀	📦 /KG	€	🚚
7452.4140	1200	1100	450	2	✓	X	✓	X	61	861,-	🚚
7452.4144	1600	1100	450	2	✓	X	✓	X	71	991,-	🚚
7452.4148	2000	1100	450	3	✓	X	✓	X	82	1.233,-	🚚
7452.4152	2400	1100	450	4	✓	X	✓	X	92	1.418,-	🚚
7452.4156	2800	1100	450	4	✓	X	✓	X	103	1.619,-	🚚
7452.4158	3000	1100	450	5	✓	X	✓	X	108	1.689,-	🚚



MOUNTED HOOD

- WANDKAP
- WANDHAUBEN
- MOUNTED HOOD
- HOTTES MURALES



	L	D	H	FILTERS	💡	🕒	🔧	🌀	📦 /KG	€	🚚
7411.1700	1000	800	600	1	X	X	X	X	29	558,-	🚚
7411.1702	1500	800	600	2	X	X	X	X	36	636,-	🚚
7411.1704	2000	800	600	3	X	X	X	X	46	755,-	🚚
7411.1706	2500	800	600	4	X	X	X	X	56	898,-	🚚
7411.1708	3000	800	600	5	X	X	X	X	71	1.060,-	🚚

EXPORT OP AANVRAAG

EXPORT ON REQUEST

EXPORT AUF ANFRAGE

EXPORT SUR DEMANDE

7411.1710	3500	800	600	6	X	X	X	X	83	1.210,-	🚚
7411.1712	4000	800	600	6	X	X	X	X	97	1.316,-	🚚

MOUNTED HOOD

- WANDKAP
- WANDHAUBEN
- MOUNTED HOOD
- HOTTES MURALES



	L	D	H	FILTERS	💡	🕒	🔧	🌀	📦 /KG	€	🚚
7411.1000	1200	1100	450	2	X	X	✓	X	65	705,-	🚚
7411.1005	1600	1100	450	2	X	X	✓	X	75	813,-	🚚
7411.1010	2000	1100	450	3	X	X	✓	X	81	963,-	🚚
7411.1015	2400	1100	450	4	X	X	✓	X	88	1.139,-	🚚
7411.1020	2800	1100	450	4	X	X	✓	X	98	1.302,-	🚚
7411.1025	3000	1100	450	5	X	X	✓	X	100	1.373,-	🚚



WALL-MOUNTED HOOD

- WANDKAP
- WANDHAUBEN
- WALL-MOUNTED HOOD
- HOTTES MURALES



	L	D	H	⚡	FILTERS	💡	Ⓜ	🌀	🗿	KG	€	🚚
7438.0122	1200	1100	450	230 V / 0,184 kW	2	✓	✓	✓	✓	65	1.306,-	🚚
7438.0124	1600	1100	450	230 V / 0,184 kW	2	✓	✓	✓	✓	75	1.428,-	🚚
7438.0126	2000	1100	450	230 V / 0,184 kW	3	✓	✓	✓	✓	81	1.718,-	🚚
7438.0128	2400	1100	450	230 V / 0,42 kW	4	✓	✓	✓	✓	88	1.895,-	🚚
7438.0130	2800	1100	450	230 V / 0,42 kW	4	✓	✓	✓	✓	98	2.088,-	🚚
7438.0132	3000	1100	450	230 V / 0,42 kW	5	✓	✓	✓	✓	100	2.256,-	🚚

CONDENSATION HOOD

- CONDENSAP
- KONDENSATIONSHAUBEN
- CONDENSATION HOOD
- HOTTES DE CONDENSATION



	L	D	H	KG	€	🚚
7411.0187	1000	1000	400	50	610,-	🚚



CENTRAL HOOD

- EILANDKAP
- ZENTRALHAUBEN
- CENTRAL HOOD
- HOTTES CENTRALES



	L	D	H	FILTERS	💡	Ⓜ	🌀	🗿	KG	€	🚚
7411.1740	1500	2000	400	4	X	X	X	X	140	1.401,-	🚚
7411.1742	2000	2000	400	6	X	X	X	X	170	1.793,-	🚚
7411.1744	2500	2000	400	8	X	X	X	X	220	2.080,-	🚚
7411.1746	3000	2000	400	10	X	X	X	X	260	2.366,-	🚚

- EXPORT OP AANVRAAG
- EXPORT ON REQUEST
- EXPORT AUF ANFRAGE
- EXPORT SUR DEMANDE

7411.1748	3500	2000	400	12	X	X	X	X	290	2.653,-	🚚
7411.1749	4500	2000	400	14	X	X	X	X	370	3.360,-	🚚
7411.1750	4000	2000	400	12	X	X	X	X	330	2.863,-	🚚
7411.1751	5000	2000	400	16	X	X	X	X	410	3.647,-	🚚

CENTRAL HOOD

- EILANDKAP
- ZENTRALHAUBEN
- CENTRAL HOOD
- HOTTES CENTRALES

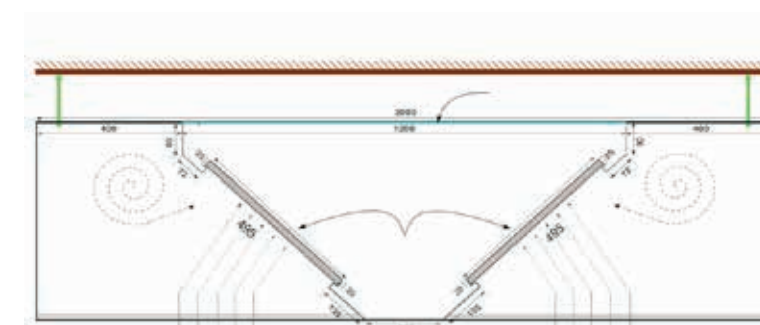





	L	D	H	FILTERS	💡	Ⓜ	🌀	🗿	KG	€	🚚
7411.1752	1500	2000	540	4	X	X	X	X	146	1.501,-	🚚
7411.1754	2000	2000	540	6	X	X	X	X	180	1.918,-	🚚
7411.1756	2500	2000	540	8	X	X	X	X	225	2.222,-	🚚
7411.1758	3000	2000	540	10	X	X	X	X	264	2.525,-	🚚

- EXPORT OP AANVRAAG
- EXPORT ON REQUEST
- EXPORT AUF ANFRAGE
- EXPORT SUR DEMANDE

7411.1760	3500	2000	540	12	X	X	X	X	310	2.828,-	🚚
7411.1762	4500	2000	540	12	X	X	X	X	350	3.055,-	🚚
7411.1764	4000	2000	540	14	X	X	X	X	390	3.585,-	🚚
7411.1766	5000	2000	540	16	X	X	X	X	440	3.889,-	🚚

INDUCTION BOX MODEL

-  INDUCTIEKAP DOOSMODEL
-  INDUKTIONSHAUBEN DOSENMODELL
-  INDUCTION BOX MODEL
-  HOTTES D'INDUCTION MODÈLE DE BOÎTE

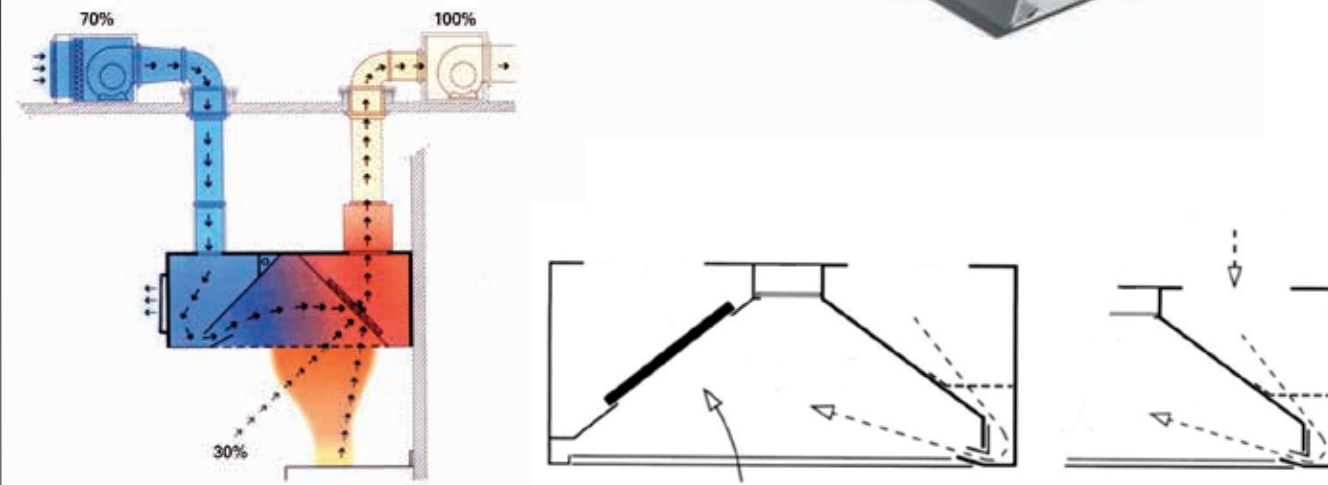





	L	D	H	FILTERS	Light	Motor	Blower	Weight (KG)	€
7438.0060	1500	1000	500	2	X	X	X	74	2.661,-
7438.0062	1750	1000	500	3	X	X	X	87	2.866,-
7438.0064	2000	1000	500	3	X	X	X	100	3.014,-
7438.0066	2250	1000	500	3	X	X	X	109	3.183,-
7438.0068	2500	1000	500	4	X	X	X	119	3.410,-
7438.0070	2750	1000	500	4	X	X	X	125	3.608,-
7438.0072	3000	1000	500	5	X	X	X	132	3.798,-

-  EXPORT OP AANVRAAG
-  EXPORT ON REQUEST
-  EXPORT AUF ANFRAGE
-  EXPORT SUR DEMANDE

7438.0074	3250	1000	500	5	X	X	X	142	3.995,-
7438.0076	3500	1000	500	5	X	X	X	152	4.194,-
7438.0078	3750	1000	500	6	X	X	X	170	4.391,-
7438.0080	4000	1000	500	6	X	X	X	185	4.589,-

INDUCTION CENTRAL HOOD

-  INDUCTIEKAP EILANDMODEL
-  INDUKTION ZENTRALHAUBEN
-  INDUCTION CENTRAL HOOD
-  HOTTES D'INDUCTION CENTRALES

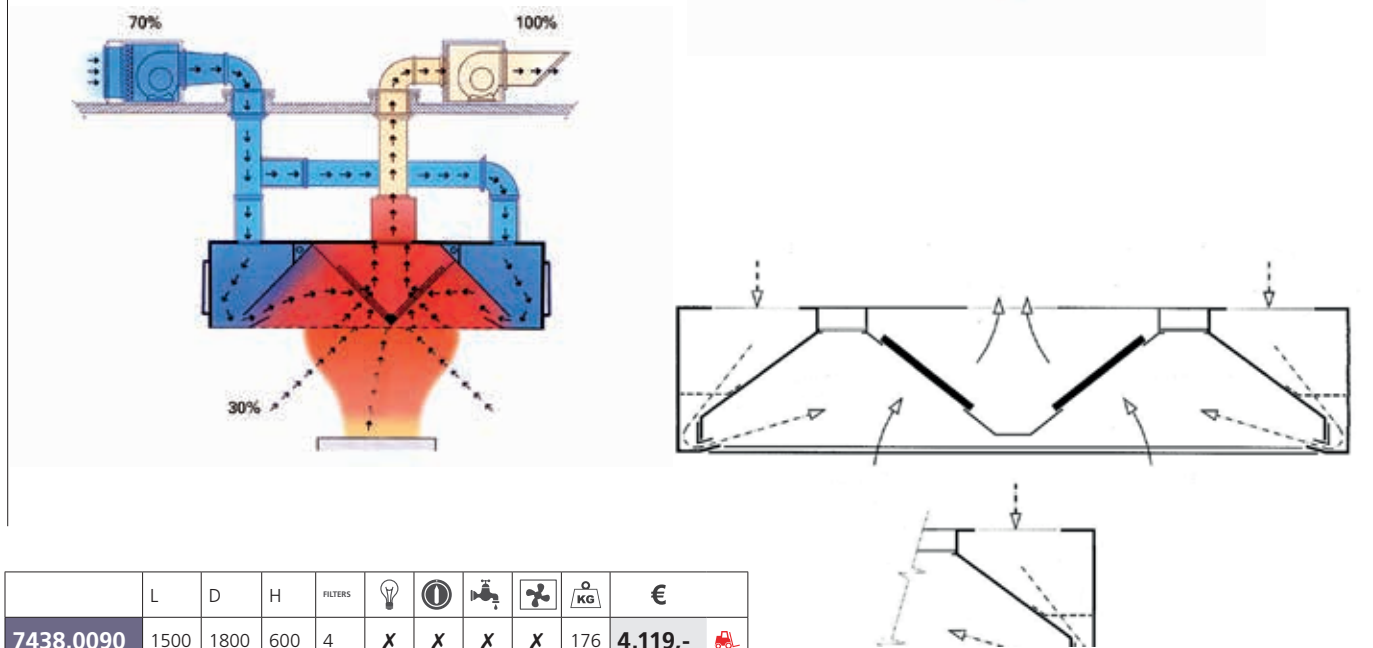

	L	D	H	FILTERS	Light	Motor	Blower	Weight (KG)	€
7438.0090	1500	1800	600	4	X	X	X	176	4.119,-
7438.0092	1750	1800	600	6	X	X	X	189	4.443,-
7438.0094	2000	1800	600	6	X	X	X	202	4.773,-
7438.0096	2250	1800	600	6	X	X	X	215	5.110,-
7438.0098	2500	1800	600	8	X	X	X	228	5.528,-
7438.0100	2750	1800	600	8	X	X	X	241	5.849,-
7438.0102	3000	1800	600	10	X	X	X	254	6.275,-

-  EXPORT OP AANVRAAG
-  EXPORT ON REQUEST
-  EXPORT AUF ANFRAGE
-  EXPORT SUR DEMANDE

7438.0104	3250	1800	600	10	X	X	X	274	7.205,-
7438.0106	3500	1800	600	10	X	X	X	294	7.499,-
7438.0108	3750	1800	600	12	X	X	X	330	7.895,-
7438.0110	4000	1800	600	12	X	X	X	360	8.186,-

AIR CLEANER A

- GEURFILTERKAST A
Doosfilter + koolstofpatroon
- ABLUFTREINIGUNGSANLAGE A
Dosenfilter + Kohlstofffilter
- AIR CLEANER A
Box filter + carbon filter
- FILTRE À AIR A
Filtre de boîte + filtre carbone



	L	D	H	⚡	MP	FILTERS	KG	€
7223.0515	800	700	400	230	1500	8	45	1.115,-
7223.0520	800	700	700	230	2500	12	55	1.490,-

AIR CLEANER B

- GEURFILTERKAST B
Doosfilter + koolstofpatroon + motor
- ABLUFTREINIGUNGSANLAGE B
Dosenfilter + Kohlstofffilter + Motor
- AIR CLEANER B
Box filter + carbon filter + engine
- FILTRE À AIR B
Filtre de boîte + filtre carbone + moteur



	L	D	H	⚡	MP	FILTERS	KG	€
7223.0500	1250	700	700	230 V / 0,25 kW	3250	10	85	1.530,-
7223.0505	1250	700	700	230 V / 0,42 kW	4250	15	90	1.860,-
7223.0510	1500	800	800	230 V / 0,75 kW	5000	18	95	2.465,-

AIR CLEANER C

- GEURFILTERKAST C
Doosfilter + zakkenfilter + koolstofpatroon + motor
- ABLUFTREINIGUNGSANLAGE C
Dosenfilter + Säckenfilter + Kohlstofffilter + Motor
- AIR CLEANER C
Box filter + filter bags + carbon filter + engine
- FILTRE À AIR C
Filtre de boîte + filtre de sac + filtre carbone + moteur



	L	D	H	⚡	MP	FILTERS	KG	€
7052.0000	1800	670	500	230V/0,25 kW	2500	8	125	2.275,-
7052.0002	1800	670	500	230V/0,5 kW	3250	12	130	2.550,-
7052.0005	2050	670	670	230V/0,55 kW	4250	16	155	2.995,-
7052.0010	2050	970	670	230V/1kW	6000	24	170	3.825,-
7052.0015	2050	1290	670	400V/1,8 kW	7950	32	175	5.200,-

CARBONFILTER

- KOOLSTOFFPATROON
- KOHLSTOFFFILTER
- CARBONFILTER
- FILTRE CARBONE

	7223.0410
H	450
L	45
KG	4,5
€	49,-

FILTER BAGS

- ZAKKENFILTER
- SACKENFILTER
- FILTER BAGS
- FILTRE DU SAC

	7223.0420	
H	600	1/1
L	2	
KG	2	
€	92,-	

	7223.0422	
H	600	1/2
L	1,5	
KG	1,5	
€	63,-	

BOX FILTER

- DOOSFILTER
- DOSENFILTER
- BOX FILTER
- FILTRE DU BOÎTE

	7223.0430	
KG	0,45	1/1
€	46,-	

	7223.0432	
KG	0,55	1/2
€	36,-	





FAN

-  VENTILATOR
-  VENTILATOR
-  FAN
-  VENTILATEUR



	TYPE	L	D	H	⚡	Rpm	Ⓜ	Ⓜ³	ⓀG	€
7225.0045	7/7 1400	230	311	323	230 V/ 0,4 kW	1400	1,8	1500	6	191,-
7225.0050	9/7 1400	230	350	325	230 V/ 1,08 kW	1400	5,2	2650	8	275,-
7225.0055	9/9 1400	255	380	387	230 V/ 1,1 kW	1400	5	3000	9	254,-
7225.0060	10/10 1400	330	415	440	230 V/ 1,45 kW	1400	6,5	3800	11	297,-
7225.0065	12/12 900	390	493	515	230 V/ 1,4 kW	900	6,5	6500	13	415,-
7225.0070	12/12 1100	390	493	515	230 V/ 2,25 kW	1100	11	6800	14	460,-

FAN IN BOX



-  VENTILATOR IN BOX
-  VENTILATOR IN DOSE
-  FAN IN BOX
-  VENTILATEUR DANS BOÎTE



	TYPE	L	D	H	⚡	Rpm	Ⓜ	Ⓜ³	ⓀG	€
7225.0145	7/7 1400	450	450	450	230 V/ 0,4 kW	1400	1,8	1500	Ø 250	303,-
7225.0150	9/7 1400	450	450	450	230 V/ 1,08 kW	1400	5,2	2650	Ø 250	599,-
7225.0155	9/9 1400	550	550	550	230 V/ 1,1 kW	1400	5	3000	Ø 350	399,-
7225.0160	10/10 1400	650	650	650	230 V/ 1,45 kW	1400	6,5	3800	Ø 400	448,-
7225.0165	12/12 900	750	750	750	230 V/ 1,4 kW	900	6,5	6500	Ø 450	675,-
7225.0170	12/12 1100	750	750	750	230 V/ 2,25 kW	1100	11	6800	Ø 500	695,-

DAMPING RUBBER

-  DEMPINGSRUBBER
-  DÄMPFUNGSGUMMI
-  DAMPING RUBBER
-  BLOC DE SUSPENSION

7013.0003	
	100x100x20
	0,1
	5,-





FAN

-  VENTILATOR
-  VENTILATOR
-  FAN
-  VENTILATEUR



		L	D	H	⚡	Ⓜ	Ⓜ³	ⓀG	€
7001.0130	7/7	270	309	328	230 V/ 147 kW	1,5	1000	210x234	7,5 202,-
7001.0132	9/9	387	450	389	230 V/ 0,55 kW	4,3	2650	260x300	12 291,-
7001.0142	12/12	471	550	521	230 V/ 736 kW	5,4	3000	341x396	17 436,-
7001.0136	12/12	471	650	521	400 V/ 1,1 kW	5,9	3800	341x396	22 440,-





FAN IN BOX

-  VENTILATOR IN BOX
-  VENTILATOR IN DOSE
-  FAN IN BOX
-  VENTILATEUR DANS BOÎTE











		L	D	H	⚡	Ⓜ	Ⓜ³	ⓀG	€
7001.0097	7/7	445	445	455	230 V/ 147 kW	1,5	1000	Ø 250	22 437,-
7001.0100	9/9	515	555	535	230 V/ 0,55 kW	4,3	3000	Ø 350	26 504,-
7001.0106	12/12	620	675	640	230 V/ 736 kW	5,4	4500	Ø 450	30 827,-
7001.0104	12/12	620	675	640	400 V/ 1,1 kW	5,9	6000	Ø 450	30 795,-
7001.0109	15/15	950	780	770	400 V/ 1,5 kW	6,8	9000	Ø 475	35 1.144,-





DUCT VENTILATOR

-  BUISVENTILATOR
-  VROHRVENTILATOR
-  DUCT VENTILATOR
-  VENTILATEUR DE TUYAU





	L	⚡	M ³	KG	€	
7225.0005	100	230 V / 0,059 kW	250	1,2	95,-	
7225.0010	125	230 V / 0,061 kW	365	1,5	97,-	
7225.0015	150 / 160	230 V / 0,064 kW	495	1,6	103,-	
7225.0020	200	230 V / 0,11 kW	790	1,7	139,-	
7225.0025	200 S	230 V / 0,14 kW	1100	1,7	147,-	
7225.0030	250	230 V / 0,17 kW	1150	1,9	148,-	
7225.0035	315	230 V / 0,155 kW	1325	2	165,-	
7225.0040	315 S	230 V / 0,225 kW	1700	2	218,-	

GAS REGULATER VALVE

-  GASGEBREKLEP
-  GASREGLERVENTIL
-  GAS REGULATER VALVE
-  SOUPAPE POUR RÉGLER LE GAZ





	TYPE	Ø	KG	€	
7223.0015	3/4	22	0,35	68,-	
7223.0020	1	28	0,45	299,-	
7223.0040	1,5	35	0,55	345,-	





SOLENOID VALVE

-  MAGNEETKLEP
-  MAGNETVENTIL
-  SOLENOID VALVE
-  SOUPAPE MAGNÉTIQUE



	TYPE	Ø	KG	€	
7223.0025	3/4	22	2	203,-	
7223.0030	1	28	2,4	222,-	
7223.0035	1,5	35	2,9	370,-	





LIGHT SWITCH

-  STANDREGELAAR MET DRAAIKNOP
-  ABLENDSCHALTER
-  LIGHT SWITCH
-  COMMUTATEUR D'ÉCLAIRAGE







	H	⚡	(A)	KG	€	
7438.0123	130x90x60	230 V / 2,3 kW	10	5	99,-	





SPEED GOVENOR 1 PHASE

-  STANDREGELAAR 1 FASE
-  GESCHWINDIGKEITSREGLER 1 PHASE
-  SPEED GOVENOR 1 PHASE
-  REGULATEUR DE VITESSE 1 PHASE







	TYPE	H	⚡	(A)	KG	€	
7223.0058	TM 2-3	192x152x87	230	3	2	123,-	
7223.0059	TM 2-5	192x182x148	230	5	5,5	145,-	
7223.0060	TM 2-7	235x182x148	230	7	5,5	165,-	
7223.0061	TM 2-9	235x182x148	230	9	5,5	199,-	
7223.0062	TM 2-11	235x182x148	230	11	5,5	235,-	

SPEED GOVENOR 3 PHASE

-  STANDREGELAAR 3 FASE
-  GESCHWINDIGKEITSREGLER 3 PHASE
-  SPEED GOVENOR 3 PHASE
-  REGULATEUR DE VITESSE 3 PHASE









	TYPE	H	⚡	(A)	KG	€	
7223.0065	TM 3-5	300x250x150	400	5	15	499,-	
7223.0066	TM 3-7,5	300x250x200	400	7,5	18	553,-	
7223.0067	TM 3-11	400x300x200	400	11	21	798,-	
7223.0068	TM 3-14	500x400x260	400	14	24	973,-	
7223.0069	TM 3-19	500x400x260	400	19	24	1.165,-	

LABYRINTH FILTER

-  LAMELLENFILTER
-  LAMELLENFILTER.
-  LABYRINTH FILTER
-  FILTRE DE LAMELLE









			€	
7213.0030	495x495x25	2,8	44,-	
7213.0035	400x500x25	2,5	56,-	
7213.0040	480x450x25	2,8	59,-	





FLUORESCENT LIGHT

-  TL BUIS
-  LEUCHTRÖHRE
-  FLUORESCENT LIGHT
-  TUBE LUMINESCENT







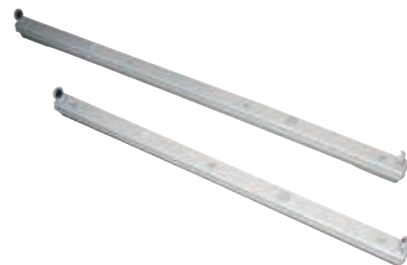

	L			€	
7924.0010	600	0,018 kW	1	18,-	
7924.0015	1400	0,036 kW	1	23,-	
7924.0020	1600	0,058 kW	1	26,-	

FLUORESCENT LAMP HOLDER

-  TL ARMATUUR
-  ARMATUR
-  FLUORESCENT LAMP HOLDER
-  ARMATURE



	L			€	
7924.0025	600	0,018 kW	2,5	31,-	
7924.0030	1400	0,036 kW	3	33,-	
7924.0035	1600	0,058 kW	4	36,-	



Cooking range

Drop-in

Ovens

Kitchen equipment

Refrigeration

Dishwashers

Neutral

Faucets

Ventilation











Pizzeria

Bakery

CONVERTER

-  VERLOOPSTUK
-  ÜBERGANGSSTÜCK
-  CONVERTER
-  ADAPTEUR









	Ø	KG	€	
7216.0638	200 - 150	1,8	20,-	
7216.0639	200 - 250	2	27,-	
7216.0640	200 - 300	2,2	27,-	
7216.0641	200 - 350	2,4	30,-	
7216.0644	250 - 300	2,6	33,-	
7216.0645	250 - 350	2,8	36,-	
7216.0650	300 - 350	3	40,-	
7216.0660	350 - 450	3,2	46,-	
7216.0670	400 - 250	3,4	40,-	
7216.0680	450 - 200	3,6	52,-	
7216.0682	450 - 250	3,8	52,-	





ALUMINIUM ALVE

-  ALUMINIUM KLEP
-  ALUMINIUMVENTIL
-  ALUMINIUM VALVE
-  SOUPAPE D'ALUMINIUM









	Ø	KG	€	
7216.1105	150	0,6	36,-	
7216.1110	200	0,7	49,-	
7216.1115	250	0,8	54,-	
7216.1120	300	0,9	65,-	
7216.1125	350	1	70,-	
7216.1130	400	1,2	80,-	
7216.1135	450	1,3	99,-	

T-PIECE 90° COMPLETE

-  T-STUK 90° COMPLEET
-  T-STÜCK 90° KOMPLETT
-  T-PIECE 90° COMPLETE
-  T-PIÈCE 90° COMPLET









	Ø	KG	€	
7215.0100	150	0,8	32,-	
7215.0110	200	1	42,-	
7215.0115	250	1,2	53,-	
7215.0120	300	1,4	57,-	
7215.0125	350	1,6	61,-	
7215.0130	400	1,8	83,-	
7215.0135	450	2	105,-	





STORM COLLAR

-  STORMKRAAG
-  STURMKRAGEN
-  STORM COLLAR
-  COL DE TEMPÊTE









	H	KG	€	
7216.0450	150x150	0,2	40,-	
7216.0452	200x200	0,25	42,-	
7216.0454	250x250	0,3	47,-	
7216.0456	300x300	0,35	47,-	
7216.0458	350x350	0,4	50,-	
7216.0460	400x400	0,45	57,-	
7216.0462	450x450	0,5	57,-	

SQUARE PIPE DUCTING

-  VIERKANTEN AFVOERBUIJS
-  VIERECKIGES ABFLUSSROHR
-  SQUARE PIPE DUCTING
-  TUYAU D'ÉVACUATION CARRÉ









	H	KG	€	
7216.0950	150x150	1,75	31,-	
7216.0955	200x200	2	41,-	
7216.0960	250x250	2,25	55,-	
7216.0965	300x300	2,5	64,-	
7216.0970	350x350	2,75	75,-	
7216.0975	400x400	3	88,-	
7216.0980	450x450	3,25	95,-	

SQUARE FLANGE

-  VIERKANTE FLENS
-  VIERECKIGER FLANSCH
-  SQUARE FLANGE
-  BRIDE CARRÉE









	H	KG	€	
7216.1020	150x150	0,25	32,-	
7216.1025	200x200	0,29	42,-	
7216.1030	250x250	0,33	56,-	
7216.1035	300x300	0,37	65,-	
7216.1040	350x350	0,41	75,-	
7216.1045	400x400	0,45	88,-	
7216.1050	450x450	0,5	95,-	



STORM COLLAR

-  STORMKRAAG
-  STURMKRAGEN
-  STORM COLLAR
-  COL DE TEMPÊTE









	Ø	KG	€	
7216.0340	200	0,3	27,-	
7216.0345	250	0,35	28,-	
7216.0350	300	0,4	32,-	
7216.0360	350	0,4	37,-	
7216.0365	400	0,45	40,-	
7216.0370	450	0,55	56,-	





ROUND FLANGE

-  AANSLUITRING
-  RUNDER FLANSCH
-  ROUND FLANGE
-  ANNEAU DE JONCTION EN ROND









	Ø	KG	€	
7216.0510	200	0,1	8,-	
7216.0515	250	0,12	10,-	
7216.0520	300	0,14	11,-	
7216.0525	350	0,16	12,-	
7216.0532	400	0,18	14,-	
7216.0530	450	0,2	16,-	





ROUND PIPE DUCTING

-  RONDE AFVOERBUIS
-  RUNDES ABFLUSSROHR
-  ROUND PIPE DUCTING
-  TUYAU D'ÉVACUATION EN ROND







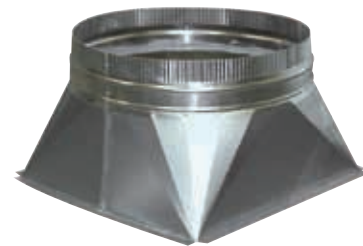

	Ø	KG	€	
7218.0200	200	2	25,-	
7218.0250	250	2,25	35,-	
7218.0300	300	2,5	40,-	
7218.0350	350	2,75	46,-	
7218.0400	400	3	58,-	
7218.0450	450	3,25	67,-	





SQUARE TO ROUND CONVERTER

-  VERLOOP VIERKANT NAAR ROND
-  VIERECKIGER-RUNDER ROHRWECHSLER
-  SQUARE TO ROUND CONVERTER
-  CONVERTISSEUR DE TAYAU CARRÉ-EN ROND







	Ø	H	KG	€	
7222.0520	200	400x400	0,3	82,-	
7222.0525	250	400x400	0,35	82,-	
7222.0530	300	400x400	0,4	82,-	
7222.0535	350	400x400	0,45	82,-	
7222.0540	400	400x400	0,5	88,-	
7222.0545	450	400x400	0,55	88,-	



VERTICAL DEFLECTOR HOOD

-  VERTICALE UITBLAASKAP
-  SENKRECHTE DEFLEKTORKAPPE
-  VERTICAL DEFLECTOR HOOD
-  HOTTE DÉFLECTEUR VERTICALE







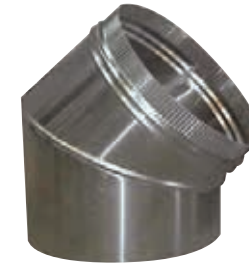

	H	TYPE	KG	€	
7216.0900	380x250x400	51	2	82,-	
7216.0905	440x300x550	63	2,5	91,-	
7216.0910	540x340x550	76	3	117,-	
7216.0915	750x350x700	100	3,5	132,-	

ELBOW ROUND 45°

-  BOCHT ROND 45°
-  KURVE RUND 45°
-  ELBOW ROUND 45°
-  COURBE EN ROND 45°









	Ø	KG	€	
7220.0040	200	0,6	22,-	
7220.0045	250	0,7	36,-	
7220.0050	300	0,8	43,-	
7220.0060	350	0,9	52,-	
7220.0065	400	1	61,-	
7220.0067	450	1,1	74,-	



RAIN COVER

-  REGENKAP
-  REGENKAPPE
-  RAIN COVER
-  CAPUCHON DE PLUIE









	Ø	KG	€	
7217.0200	200	0,4	30,-	
7217.0250	250	0,6	33,-	
7217.0300	300	0,8	40,-	
7217.0350	350	1	43,-	
7217.0400	400	1,2	50,-	
7217.0450	450	1,4	57,-	

ELBOW ROUND 90°

-  BOCHT ROND 90°
-  KURVE RUND 90°
-  ELBOW ROUND 90°
-  COURBE EN ROND 90°



	Ø	KG	€	
7220.0122	200	0,7	24,-	
7220.0125	250	0,9	41,-	
7220.0150	300	1,1	46,-	
7220.0160	350	1,3	57,-	
7220.0165	400	1,5	73,-	
7220.0167	450	1,7	78,-	



HOSERING FOR FLEXIBLE HOSE

- SLANGENKLEM
- SCHLAUCHKLEMME
- HOSERING FOR FLEXIBLE HOSE
- AGRAFFE DE TUYAU POUR DES TUYAUX FLEXIBLES

	Ø	KG	€	
7216.0170	< 200	15	3,-	
7216.0175	< 325	25	3,-	

FLEXIBLE DUCT DOUBLE SKIN

- FLEXIBELE SLANG GEÏSOLEERD
- FLEXIBELER SLAUCH ISOLIERT
- FLEXIBLE DUCT DOUBLE SKIN
- TUYAU FLEXIBLE ISOLÉ

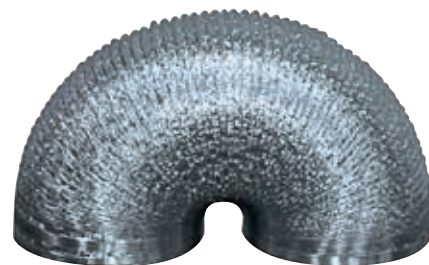

	Ø	L	KG	€	
7218.0800	127	10 m	0,5	170,-	
7218.0802	152	10 m	0,52	180,-	
7218.0804	160	10 m	0,53	190,-	
7218.0815	200	10 m	0,55	240,-	
7218.0820	250	10 m	0,6	260,-	
7218.0827	315	10 m	0,66	310,-	
7218.0829	350	10 m	0,7	330,-	
7218.0835	400	10 m	0,74	370,-	

FLEXIBLE DUCT SINGLE SKIN

- FLEXIBELE SLANG ONGEÏSOLEERD
- FLEXIBELER SLAUCH NICHT ISOLIERT
- FLEXIBLE DUCT SINGLE SKIN
- TUYAU FLEXIBLE NON ISOLÉ

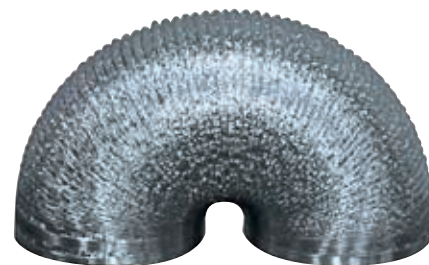

	Ø	L	KG	€	
7218.0840	127	10 m	0,48	90,-	
7218.0842	152	10 m	0,5	100,-	
7218.0844	160	10 m	0,51	100,-	
7218.0846	200	10 m	0,53	120,-	
7218.0848	250	10 m	0,58	150,-	
7218.0850	315	10 m	0,64	170,-	
7218.0852	350	10 m	0,68	190,-	
7218.0854	400	10 m	0,72	230,-	

DEFLECTOR HOOD ROUND

- DEFLECTORKAP ROND
- DEFLEKTORKAPPE RUND
- DEFLECTOR HOOD ROUND
- HOTTE DE DÉFLECTEUR RONDE



	Ø	KG	€	
7222.0190	150	3,5	118,-	
7222.0200	200	3,7	131,-	
7222.0250	250	3,9	157,-	
7222.0300	300	4,1	183,-	
7222.0350	350	4,3	229,-	
7222.0400	400	4,5	267,-	
7222.0450	450	4,8	320,-	

ELBOW 90° SQUARE

- BOCHT 90° VIERKANT
- 90° GRAD KURVE VIERECKIG
- ELBOW 90° SQUARE
- 90° DEGRES COURBE CARRÉ



	L	KG	€	
7220.0200	150x150	0,7	44,-	
7220.0205	200x200	0,78	53,-	
7220.0210	250x250	0,86	74,-	
7220.0215	300x300	0,94	85,-	
7220.0220	350x350	1,2	95,-	
7220.0225	400x400	2	105,-	
7220.0230	450x450	2,8	118,-	

ELBOW 45° SQUARE

- BOCHT 45° VIERKANT
- 45° GRAD KURVE VIERECKIG
- ELBOW 45° SQUARE
- 45° DEGRES COURBE CARRÉ

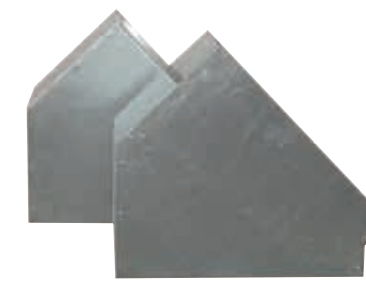







	L	KG	€	
7216.0985	150x150	0,6	38,-	
7216.0990	200x200	0,68	48,-	
7216.0995	250x250	0,76	66,-	
7216.1000	300x300	0,84	79,-	
7216.1005	350x350	0,92	88,-	
7216.1010	400x400	1	96,-	
7216.1015	450x450	1,8	111,-	

SADDLE RIGHT FLANK

-  T STUK RECHT
-  T STÜCK GERADE
-  SADDLE RIGHT FLANK
-  T PIÈCE DROITE











	Ø	KG	€	
7215.0000	150	0,8	15,-	
7215.0010	200	1	22,-	
7215.0015	250	1,2	26,-	
7215.0020	300	1,4	27,-	
7215.0025	350	1,6	28,-	
7215.0030	400	1,8	36,-	
7215.0035	450	2	42,-	

SADDLE PIECE 45°

-  T STUK SCHUIN
-  T STÜCK SCHRÄG
-  SADDLE PIECE 45°
-  T-PIÈCE OBLIQUE











	Ø	KG	€	
7215.0050	150	0,7	20,-	
7215.0055	180	0,8	20,-	
7215.0060	200	0,9	31,-	
7215.0065	250	1,1	35,-	
7215.0070	300	1,3	40,-	
7215.0075	350	1,5	49,-	
7215.0080	400	1,7	53,-	
7215.0085	450	1,9	67,-	





END CAP

-  EINDDOP
-  ENDDECKEL
-  END CAP
-  BOUCHON FINAL







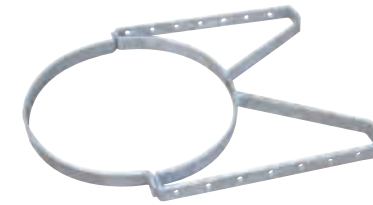

	Ø	KG	€	
7216.0704	150	0,5	9,-	
7216.0706	180	0,6	9,-	
7216.0708	200	0,7	10,-	
7216.0710	250	0,85	11,-	
7216.0712	300	1	15,-	
7216.0714	350	1,15	19,-	
7216.0716	400	1,3	25,-	
7216.0718	450	1,45	28,-	

WALL MOUNT BRACKET

-  MUURBEUGEL
-  WANDBIEGEL
-  WALL MOUNT BRACKET
-  ANSE MURALE







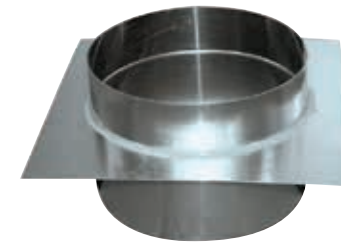

	Ø	KG	€	
7224.0200	200	2,6	64,-	
7224.0250	250	2,8	69,-	
7224.0300	300	3	74,-	
7224.0355	355	3,2	79,-	
7224.0400	400	3,3	85,-	
7224.0450	450	3,5	93,-	
7224.0500	500	3,7	93,-	





DUCT CONNECTION RIGHT

-  DAKDOORVOER
-  DACHTRANSIT
-  DUCT CONNECTION RIGHT
-  TRANSIT DE TOIT









	Ø	KG	€	
7221.0045	200	0,35	35,-	
7221.0050	250	0,5	44,-	
7221.0055	300	0,65	48,-	
7221.0065	350	0,8	50,-	
7221.0070	400	0,95	63,-	
7221.0075	450	1,1	80,-	

ROSETTES

-  ROZETTEN
-  ROSETTEN
-  ROSETTES
-  ROSETTES



	Ø	KG	€	
7216.0850	150	0,08	6,-	
7216.0854	200	0,95	7,-	
7216.0860	250	0,11	15,-	
7216.0865	300	0,125	20,-	
7216.0870	350	0,14	23,-	
7216.0875	400	0,155	26,-	
7216.0880	450	0,17	29,-	



Pizzeria
Pizzeria
Pizzeria
Pizzeria

Cooking range

Drop-in

Ovens

Kitchen equipment

Refrigeration

Dishwashers

Neutral

Faucets

Ventilation

Pizzeria

Bakery

PIZZA COUNTER

- PIZZAWERKBANK
- PIZZA TISCH
- PIZZA COUNTER
- TABLE PRÉP POUR PIZZA

GREY LABEL



7950.0040	
1515x800x1000	+2 / +8 °C
945x680x560	EN 2x 600x400
230 V / 0,34 kW	R R 134 A
280	
€ 1.515,-	

PIZZA COUNTER WITH DRAWERS

- PIZZAWERKBANK MET LADEN
- PIZZA TISCH MIT LADEN
- PIZZA COUNTER WITH DRAWERS
- TABLE PRÉP POUR PIZZA AVEC TIROIRS

GREY LABEL



7950.0042	
2025x800x1000	+2 / +8 °C
945x680x560	EN 2x 600x400
230 V / 0,34 kW	R R 134 A
295	
€ 2.090,-	

GREY LABEL



7950.0044	
2025x800x1000	+2 / +8 °C
1455x680x560	EN 3x 600x400
230 V / 0,34 kW	R R 134 A
295	
€ 1.850,-	

ACCESSORIES

	7045.0007		
EN	600x400	€ 29,-	
	7020.0600	> 7950.0042	
EN	600x400x70	€ 17,-	

REFRIGERATED COUNTER TOP

- GEKOELDE OPZETVITRINE
- AUFSATZVITRINE
- REFRIGERATED COUNTER TOP
- PUIS RÉFRIGÉRATÉE



	7450.0018	7450.0023
>	7950.0040	7950.0042 7950.0044
	1500x395x435	2000x395x435
	230 V / 0,34 kW	230 V / 0,34 kW
	+2 / +8	+2 / +8
R	R 134 A	R 134 A
	11	14
€	681,-	773,-

PIZZA COUNTER

- PIZZAWERKBANK
- PIZZA TISCH
- PIZZA COUNTER
- TABLE PRÉP POUR PIZZA



7450.0040	
1515x800x1000	+2 / +8 °C
945x680x560	EN 2x 600x400
230 V / 0,34 kW	R R 134 A
280	
€ 2.095,-	



7450.0044	
2025x800x1000	+2 / +8 °C
1455x680x560	EN 3x 600x400
230 V / 0,34 kW	R R 134 A
295	
€ 2.199,-	

ACCESSORIES

	7045.0007		
EN	600x400	€ 29,-	
	7020.0600	> 7450.0042	
EN	600x400x70	€ 17,-	

PIZZA COUNTER WITH DRAWERS

- PIZZAWERKBANK MET LADEN
- PIZZA TISCH MIT LADEN
- PIZZA COUNTER WITH DRAWERS
- TABLE PRÉP POUR PIZZA AVEC TIROIRS



7450.0042	
2025x800x1000	+2 / +8 °C
945x680x560	EN 2x 600x400
230 V / 0,34 kW	R R 134 A
295	
€ 2.415,-	





REFRIGERATED COUNTER TOP

- GEKOELDE OPZETVITRINE
- AUFSATZVITRINE
- REFRIGERATED COUNTER TOP
- PUIS RÉFRIGÉRATÉE











	7450.0018	7450.0023
>	7950.0040	7450.0042 7450.0044
	1500x395x435	2000x395x435
	230 V / 0,34 kW	230 V / 0,34 kW
	+2 / +8	+2 / +8
R	R 134 A	R 134 A
	11	14
€	681,-	773,-

PIZZA COUNTER





-  PIZZAWERKBANK
-  PIZZA TISCH
-  PIZZA COUNTER
-  TABLE PRÉP POUR PIZZA

GREY LABEL











7950.0070			
	903x700x1090		230
	830x595x456	R	R 134 A
	230 V / 0,34 kW	GN	2 x 1/1
	+2 / +8 °C		✓
	95		✓
€	895,-		

PIZZA COUNTER

-  PIZZAWERKBANK
-  PIZZA TISCH
-  PIZZA COUNTER
-  TABLE PRÉP POUR PIZZA

GREY LABEL











7950.0060			
	1400x700x1020		+2 / +8 °C
	1291x595x456	R	R 134 A
	230 V / 0,34 kW	GN	3 x 1/1
	130		✓
€	1.375,-		

PIZZA COUNTER

-  PIZZAWERKBANK
-  PIZZA TISCH
-  PIZZA COUNTER
-  TABLE PRÉP POUR PIZZA











7450.0070			
	903x700x1090		230
	830x595x456	R	R 134 A
	230 V / 0,34 kW	GN	2 x 1/1
	+2 / +8 °C		✓
	95		✓
€	980,-		

PIZZA COUNTER









-  PIZZAWERKBANK
-  PIZZA TISCH
-  PIZZA COUNTER
-  TABLE PRÉP POUR PIZZA







7450.0060			
	1400x700x1020		+2 / +8 °C
	1291x595x456	R	R 134 A
	230 V / 0,34 kW	GN	3 x 1/1
	130		✓
€	1.478,-		

GREY LABEL









7950.0065			
	1368x700x1090		+2 / +8 °C
	1295x595x456	R	R 134 A
	230 V / 0,34 kW	GN	3 x 1/1
	155		✓
€	1.395,-		









REFRIGERATED COUNTER TOP

-  GEKOELDE OPZETVITRINE
-  AUFSATZVITRINE
-  REFRIGERATED COUNTER TOP
-  PUIITS RÉFRIGÉRATÉE







7950.0007			
>	7950.0060		+2 / +8 °C
	1400x335x435	R	R 134 A
	230 V / 0,34 kW		✓
	10		✓
€	648,-		









7450.0065			
	1368x700x1090		+2 / +8 °C
	1295x595x456	R	R 134 A
	230 V / 0,34 kW	GN	3 x 1/1
	155		✓
€	1.580,-		

REFRIGERATED COUNTER TOP

-  GEKOELDE OPZETVITRINE
-  AUFSATZVITRINE
-  REFRIGERATED COUNTER TOP
-  PUIITS RÉFRIGÉRATÉE









7450.0007			
>	7450.0060		+2 / +8 °C
	1400x335x435	R	R 134 A
	230 V / 0,34 kW		✓
	10		✓
€	648,-		

Cooking range
Drop-in
Ovens
Kitchen equipment
Refrigeration
Dishwashers
Neutral
Faucets
Ventilation
Pizzeria
Bakery

PIZZA COUNTER

-  PIZZAWERKBANK
-  PIZZA TISCH
-  PIZZA COUNTER
-  TABLE PRÉP POUR PIZZA









7450.0578	
 1000x700x1060	 +2 / +8 °C
 365x595x456	R R 134 A
 230 V / 0,34 kW	GN 1 x 1/1
 200	 ✓
€ 1.612,-	 ✓

PIZZA COUNTER

-  PIZZAWERKBANK
-  PIZZA TISCH
-  PIZZA COUNTER
-  TABLE PRÉP POUR PIZZA









7450.0580	
 1420x700x1060	 +2 / +8 °C
 830x595x456	R R 134 A
 230 V / 0,34 kW	GN 2 x 1/1
 268	 ✓
€ 1.718,-	 ✓

PIZZA COUNTER

-  PIZZAWERKBANK
-  PIZZA TISCH
-  PIZZA COUNTER
-  TABLE PRÉP POUR PIZZA









7450.0585	
 1795x700x1060	 +2 / +8 °C
 1291x595x456	R R 134 A
 230 V / 0,34 kW	GN 3 x 1/1
 325	 ✓
€ 2.146,-	 ✓

PIZZA COUNTER

-  PIZZAWERKBANK
-  PIZZA TISCH
-  PIZZA COUNTER
-  TABLE PRÉP POUR PIZZA



7450.0220	
 1368x700x1180	 +2 / +8 °C
 1395x595x456	R R 134 A
 230 V / 0,34 kW	GN 3 x 1/1
 155	 ✓
€ 1.695,-	 ✓





GN CONTAINER

-  GN PAN
-  GN BEHÄLTER
-  GN CONTAINER
-  GN RÉCIPIENT



	L	D	H	GN	KG	€
7476.0050	530	325	20	1/1	1	12,-
7476.0055	530	325	40	1/1	1	14,-
7476.0060	530	325	65	1/1	1	15,-
7476.0160	530	325	100	1/1	1	16,-
7476.0065	530	325	150	1/1	1	17,-
7476.0165	325	265	65	1/2	1	9,-
7476.0170	325	265	100	1/2	1	13,-
7476.0070	325	265	150	1/2	1	17,-
7476.0175	325	176	65	1/3	1	8,-
7476.0180	325	176	100	1/3	1	10,-
7476.0075	325	176	150	1/3	1	15,-
7476.0185	265	162	65	1/4	1	7,-
7476.0190	265	162	100	1/4	1	9,-
7476.0080	265	162	150	1/4	1	13,-
7476.0195	176	162	65	1/6	1	6,-
7476.0200	176	162	100	1/6	1	8,-
7476.0085	176	162	150	1/6	1	10,-
7476.0090	176	108	100	1/9	1	8,-

GN CONTAINER PERFORATED

-  GN PAN GEPERFOREERD
-  GN BEHÄLTER PERFORIERT
-  GN CONTAINER PERFORATED
-  GN RÉCIPIENT PERFORÉ



	L	D	H	GN	KG	€
7476.0205	530	325	65	1/1	65	17,-
7476.0210	530	325	150	1/1	150	21,-
7476.0215	325	265	65	1/2	65	15,-
7476.0220	325	265	150	1/2	150	19,-

GN BAR

-  GN STEG
-  GN STEGE
-  GN BAR
-  GN BARRE



	H	GN	KG	€
7216.1150	20	1/1	1	14,-
7216.1151	20	1/2	1	12,-
7216.1152	20	1/3	1	12,-
7216.1153	20	1/4	1	10,-
7216.1154	20	1/6	1	7,-

GN LID

-  GN DEKSEL
-  GN DECKEL
-  GN LID
-  GN COUVRIR



	GN	KG	€
7476.0100	1/1	1	12,-
7476.0105	1/2	1	8,-
7476.0110	1/3	1	6,-
7476.0115	1/4	1	5,-
7476.0120	1/6	1	5,-
7476.0125	1/9	1	4,-



REFRIGERATED COUNTER TOP

- GEKOELDE OPZETVITRINE
- AUFSATZVITRINE
- REFRIGERATED COUNTER TOP
- PUITS RÉFRIGÉRATÉE



	L	D	H	⚡	🌡️ °C	R	GN	🌿	🔌 A	📦 KG	€	🚚
7450.0015	1200	395	435	230 V / 0,34 kW	+2 / +8 °C	R 134 A	1/3	✓	✓	10	628,-	🚚
7450.0017	1400	395	435	230 V / 0,34 kW	+2 / +8 °C	R 134 A	1/3	✓	✓	11	668,-	🚚
7450.0019	1600	395	435	230 V / 0,34 kW	+2 / +8 °C	R 134 A	1/3	✓	✓	12	694,-	🚚
7450.0021	1800	395	435	230 V / 0,34 kW	+2 / +8 °C	R 134 A	1/3	✓	✓	13	732,-	🚚
7450.0023	2000	395	435	230 V / 0,34 kW	+2 / +8 °C	R 134 A	1/3	✓	✓	14	773,-	🚚

REFRIGERATED COUNTER TOP

- GEKOELDE OPZETVITRINE
- AUFSATZVITRINE
- REFRIGERATED COUNTER TOP
- PUITS RÉFRIGÉRATÉE



	L	D	H	⚡	🌡️ °C	R	GN	🌿	🔌 A	📦 KG	€	🚚
7450.0005	1200	335	435	230 V / 0,34 kW	+2 / +8 °C	R 134 A	1/4	✓	✓	9	628,-	🚚
7450.0007	1400	335	435	230 V / 0,34 kW	+2 / +8 °C	R 134 A	1/4	✓	✓	10	648,-	🚚
7450.0009	1600	335	435	230 V / 0,34 kW	+2 / +8 °C	R 134 A	1/4	✓	✓	11	682,-	🚚
7450.0011	1800	335	435	230 V / 0,34 kW	+2 / +8 °C	R 134 A	1/4	✓	✓	12	716,-	🚚
7450.0013	2000	335	435	230 V / 0,34 kW	+2 / +8 °C	R 134 A	1/4	✓	✓	13	740,-	🚚



REFRIGERATED COUNTER TOP SS TOP

- OPZETVITRINE RVS DEKSEL
- AUFSATZVITRINE EDELSTAHL DECKEL
- REFRIGERATED COUNTER TOP SS TOP
- PUITS RÉFRIGÉRATÉE COUVERCLE EN ACIER INC



	L	D	H	⚡	🌡️ °C	GN	🌿	🔌 A	📦 KG	€	🚚
7450.0031	1200	395	225	230 V / 0,34 kW	+2 / +7 °C	1/3	✓	✓	33	664,-	🚚
7450.0033	1500	395	225	230 V / 0,34 kW	+2 / +7 °C	1/3	✓	✓	39	699,-	🚚
7450.0035	2000	395	225	230 V / 0,34 kW	+2 / +7 °C	1/3	✓	✓	45	790,-	🚚

REFRIGERATED COUNTER TOP SS TOP

- OPZETVITRINE RVS DEKSEL
- AUFSATZVITRINE EDELSTAHL DECKEL
- REFRIGERATED COUNTER TOP SS TOP
- PUITS RÉFRIGÉRATÉE COUVERCLE EN ACIER INC

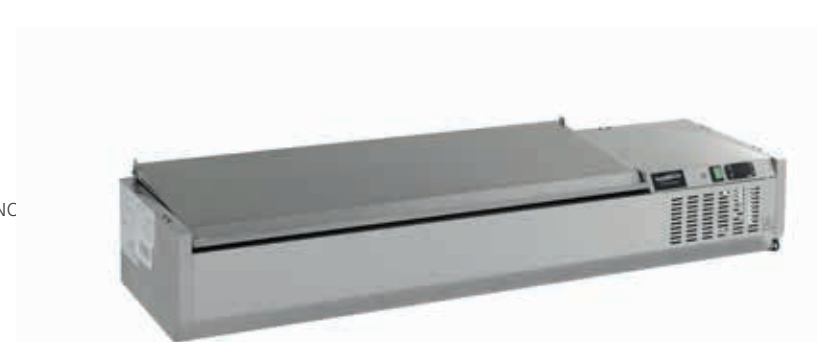









	L	D	H	⚡	🌡️ °C	GN	🌿	🔌 A	📦 KG	€	🚚
7450.0025	1200	335	225	230 V / 0,34 kW	+2 / +7 °C	1/4	✓	✓	29	620,-	🚚
7450.0027	1500	335	225	230 V / 0,34 kW	+2 / +7 °C	1/4	✓	✓	33	664,-	🚚
7450.0029	2000	335	225	230 V / 0,34 kW	+2 / +7 °C	1/4	✓	✓	39	768,-	🚚

PIZZA OVEN

-  PIZZA OVEN
-  PIZZAÖFEN
-  PIZZA OVEN
-  FOUR À PIZZA











	7485.0005			
		568x430x425		32
		2 x 410x360x90		2
		230 V / 2,4 kW		+50 / +320 °C
		34		
	€ 644,-			

PIZZA OVEN

-  PIZZA OVEN
-  PIZZAÖFEN
-  PIZZA OVEN
-  FOUR À PIZZA









	7455.1095			
		685x675x430		45
		2x 500x500x115		2
		230 V / 3 kW		
		71		
	€ 515,-			

PIZZA OVEN

-  PIZZA OVEN
-  PIZZAÖFEN
-  PIZZA OVEN
-  FOUR À PIZZA









	7482.0020			
		980x930x750		400V / 9,4kW
		2x 660x660x140		2 x 4
		125		
		€ 1.499,-		

PIZZA OVEN





-  PIZZA OVEN
-  PIZZAÖFEN
-  PIZZA OVEN
-  FOUR À PIZZA







	7482.0025			
		980x1220x750		400V/14,4kW
		2x 660x990x140		2 x 6
		178		
		€ 2.090,-		

SUPPORT

-  ONDERSTEL
-  UNTERGESTELLE
-  SUPPORT
-  SUPPORT





	7482.0035			
	>	7482.0025		
		979x1109x860		
		28		
		€ 297,-		





	7482.0030			
	>	7482.0020		
		819x979x860		
		24		
		€ 269,-		





PIZZA OVEN GAS





-  PIZZA OVEN GAS
-  PIZZAÖFEN GAS
-  PIZZA OVEN GAS
-  FOUR À PIZZA À GAZ











7485.0010																					
	<table border="1"> <tr> <td>H</td> <td>1005x930x560</td> <td>Ø</td> <td>30</td> </tr> <tr> <td>H</td> <td>620x620x150</td> <td>🔥</td> <td>4</td> </tr> <tr> <td>⚡</td> <td>230 V / 16,1 kW</td> <td>🌡️</td> <td>+0 / +450 °C</td> </tr> <tr> <td>KG</td> <td>127</td> <td></td> <td></td> </tr> <tr> <td>€</td> <td>3.198,-</td> <td></td> <td></td> </tr> </table>	H	1005x930x560	Ø	30	H	620x620x150	🔥	4	⚡	230 V / 16,1 kW	🌡️	+0 / +450 °C	KG	127			€	3.198,-		
H	1005x930x560	Ø	30																		
H	620x620x150	🔥	4																		
⚡	230 V / 16,1 kW	🌡️	+0 / +450 °C																		
KG	127																				
€	3.198,-																				

7485.0025									
	<table border="1"> <tr> <td>></td> <td>7485.0010</td> </tr> <tr> <td>H</td> <td>1005x840x960</td> </tr> <tr> <td>KG</td> <td>18</td> </tr> <tr> <td>€</td> <td>266,- </td> </tr> </table>	>	7485.0010	H	1005x840x960	KG	18	€	266,- 
>	7485.0010								
H	1005x840x960								
KG	18								
€	266,- 								

7485.0015																					
	<table border="1"> <tr> <td>H</td> <td>1005x1220x560</td> <td>Ø</td> <td>30</td> </tr> <tr> <td>H</td> <td>620x920x150</td> <td>🔥</td> <td>6</td> </tr> <tr> <td>⚡</td> <td>230 V / 21,5 kW</td> <td>🌡️</td> <td>+0 / +450 °C</td> </tr> <tr> <td>KG</td> <td>159</td> <td></td> <td></td> </tr> <tr> <td>€</td> <td>3.752,-</td> <td></td> <td></td> </tr> </table>	H	1005x1220x560	Ø	30	H	620x920x150	🔥	6	⚡	230 V / 21,5 kW	🌡️	+0 / +450 °C	KG	159			€	3.752,-		
H	1005x1220x560	Ø	30																		
H	620x920x150	🔥	6																		
⚡	230 V / 21,5 kW	🌡️	+0 / +450 °C																		
KG	159																				
€	3.752,-																				

7485.0030									
	<table border="1"> <tr> <td>></td> <td>7485.0015</td> </tr> <tr> <td>H</td> <td>1005x1140x960</td> </tr> <tr> <td>KG</td> <td>19</td> </tr> <tr> <td>€</td> <td>322,- </td> </tr> </table>	>	7485.0015	H	1005x1140x960	KG	19	€	322,- 
>	7485.0015								
H	1005x1140x960								
KG	19								
€	322,- 								







7485.0020																					
	<table border="1"> <tr> <td>H</td> <td>1305x1220x560</td> <td>Ø</td> <td>30</td> </tr> <tr> <td>H</td> <td>920x920x150</td> <td>🔥</td> <td>9</td> </tr> <tr> <td>⚡</td> <td>230 V / 27 kW</td> <td>🌡️</td> <td>+0 / +450 °C</td> </tr> <tr> <td>KG</td> <td>197</td> <td></td> <td></td> </tr> <tr> <td>€</td> <td>4.522,-</td> <td></td> <td></td> </tr> </table>	H	1305x1220x560	Ø	30	H	920x920x150	🔥	9	⚡	230 V / 27 kW	🌡️	+0 / +450 °C	KG	197			€	4.522,-		
H	1305x1220x560	Ø	30																		
H	920x920x150	🔥	9																		
⚡	230 V / 27 kW	🌡️	+0 / +450 °C																		
KG	197																				
€	4.522,-																				





7485.0035									
	<table border="1"> <tr> <td>></td> <td>7485.0020</td> </tr> <tr> <td>H</td> <td>1305x1140x960</td> </tr> <tr> <td>KG</td> <td>20</td> </tr> <tr> <td>€</td> <td>378,- </td> </tr> </table>	>	7485.0020	H	1305x1140x960	KG	20	€	378,- 
>	7485.0020								
H	1305x1140x960								
KG	20								
€	378,- 								







PIZZA OVEN





-  PIZZA OVEN
-  PIZZAÖFEN
-  PIZZA OVEN
-  FOUR À PIZZA



7485.0040																					
	<table border="1"> <tr> <td>H</td> <td>1100x954x745</td> <td>Ø</td> <td>40</td> </tr> <tr> <td>H</td> <td>2x 820x840x175</td> <td>🔥</td> <td>2 x 4</td> </tr> <tr> <td>⚡</td> <td>400 V / 13,8 kW</td> <td>🌡️</td> <td>+50 / +500 °C</td> </tr> <tr> <td>KG</td> <td>177</td> <td>📏</td> <td>600x400</td> </tr> <tr> <td>€</td> <td>1.980,-</td> <td></td> <td></td> </tr> </table>	H	1100x954x745	Ø	40	H	2x 820x840x175	🔥	2 x 4	⚡	400 V / 13,8 kW	🌡️	+50 / +500 °C	KG	177	📏	600x400	€	1.980,-		
H	1100x954x745	Ø	40																		
H	2x 820x840x175	🔥	2 x 4																		
⚡	400 V / 13,8 kW	🌡️	+50 / +500 °C																		
KG	177	📏	600x400																		
€	1.980,-																				

7485.0060									
	<table border="1"> <tr> <td>></td> <td>7485.0040</td> </tr> <tr> <td>H</td> <td>1100x849x857</td> </tr> <tr> <td>KG</td> <td>27,1</td> </tr> <tr> <td>€</td> <td>291,- </td> </tr> </table>	>	7485.0040	H	1100x849x857	KG	27,1	€	291,- 
>	7485.0040								
H	1100x849x857								
KG	27,1								
€	291,- 								











7485.0045																					
	<table border="1"> <tr> <td>H</td> <td>1100x1314x745</td> <td>Ø</td> <td>35</td> </tr> <tr> <td>H</td> <td>2x820x1080x175</td> <td>🔥</td> <td>2 x 6</td> </tr> <tr> <td>⚡</td> <td>400 V / 20,4 kW</td> <td>🌡️</td> <td>+50 / +500 °C</td> </tr> <tr> <td>KG</td> <td>236</td> <td>📏</td> <td>600x400</td> </tr> <tr> <td>€</td> <td>2.464,-</td> <td></td> <td></td> </tr> </table>	H	1100x1314x745	Ø	35	H	2x820x1080x175	🔥	2 x 6	⚡	400 V / 20,4 kW	🌡️	+50 / +500 °C	KG	236	📏	600x400	€	2.464,-		
H	1100x1314x745	Ø	35																		
H	2x820x1080x175	🔥	2 x 6																		
⚡	400 V / 20,4 kW	🌡️	+50 / +500 °C																		
KG	236	📏	600x400																		
€	2.464,-																				





7485.0065									
	<table border="1"> <tr> <td>></td> <td>7485.0045</td> </tr> <tr> <td>H</td> <td>1100x1209x857</td> </tr> <tr> <td>KG</td> <td>31</td> </tr> <tr> <td>€</td> <td>358,- </td> </tr> </table>	>	7485.0045	H	1100x1209x857	KG	31	€	358,- 
>	7485.0045								
H	1100x1209x857								
KG	31								
€	358,- 								











PIZZA OVEN





-  PIZZA OVEN
-  PIZZAÖFEN
-  PIZZA OVEN
-  FOUR À PIZZA







	7485.0050			
	1500x1074x745		40	
	2x1230x840x175		2 x 6	
	400 V / 18 kW		+50 / +500 °C	
	244		600x400	
	€ 2.862,- 			

	7485.0070	
>	7485.0050	
	1504x819x857	
	33	
	€ 358,- 	







	7485.0055			
	1500x1314x745		35	
	2x1230x1080x175		2 x 9	
	400 V / 30,6 kW		+50 / +500 °C	
	348		600x400	
	€ 3.287,- 			

	7485.0075	
>	7485.0055	
	1504x1209x857	
	40	
	€ 381,- 	





DOUGH ROLLER

-  DEEG ROLLER
-  TEIGAUSSROLLER
-  DOUGH ROLLER
-  LAMINOIR À PÂTE









	7482.0005	
	480x355x430	
	140-300	
	230 V / 0,25 kW	
	20	
	€ 689,- 	



DOUGH ROLLER

-  DEEG ROLLER
-  TEIGAUSSROLLER
-  DOUGH ROLLER
-  LAMINOIR À PÂTE









	7482.0015	
	540x410x720	
	260-400	
	230 V / 0,37 kW	
	40	
	€ 1.144,- 	





DOUGH ROLLER

-  DEEG ROLLER
-  TEIGAUSSROLLER
-  DOUGH ROLLER
-  LAMINOIR À PÂTE









	7482.0010	
	440x380x615	
	140-300	
	230 V / 0,25 kW	
	27	
	€ 936,- 	

DOUGH ROLLER STRAIGHT

-  DEEG ROLLER RECHT
-  TEIGAUSSROLLER RECHT
-  DOUGH ROLLER STRAIGHT
-  LAMINOIR À PÂTE DROIT

















	7482.0017	
	540x510x680	
	260-400	
	230 V / 0,37 kW	
	41	
	€ 1.148,- 	

DOUGH MIXER





-  DEEGMENDER
-  TEIGMASCHINE
-  DOUGH MIXER
-  PÉTRIN À SPIRALES









	7455.1400
	675x400x825
	230 V / 1,1 kW
	20
	59
	€ 1.050,- 







	7455.1405
	730x445x860
	230 V / 1,5 kW
	30
	97
	€ 1.199,- 

DOUGH MIXER EXTRACTABLE BOWL

-  DEEGMENDER UITNEEMBARE KOM
-  TEIGMASCHINE HERAUSZIEHBARER SCHÜSSEL
-  DOUGH MIXER EXTRACTABLE BOWL
-  PÉTRIN À SPIRALES CUVE EXTRACTIBLE

















	7485.0100
	385x670x725
	230 V / 0,75 kW
	22
	72
	€ 1.624,- 







	7485.0110
	424x735x805
	230 V / 1,1 kW
	32
	103
	€ 1.918,- 

DOUGH MIXER

-  DEEGMENDER
-  TEIGMASCHINE
-  DOUGH MIXER
-  PÉTRIN À SPIRALES

	7485.0080
	385x670x725
	230 V / 0,75 kW
	22
	72
	€ 1.229,- 

	7485.0085
	424x735x805
	230 V / 1,1 kW
	32
	95
	€ 1.484,- 

	7485.0090
	480x805x825
	400 V / 1,1 kW
	41
	106
	€ 1.663,- 

	7485.0095
	480x805x825
	400 V / 1,5 kW
	48
	108
	€ 1.792,- 





Cooking range

Drop-in

Ovens

Kitchen equipment

Refrigeration

Dishwashers

Neutral

Faucets

Ventilation

Pizzeria



Bakkerij
Bäckerei
Bakery
Boulangerie

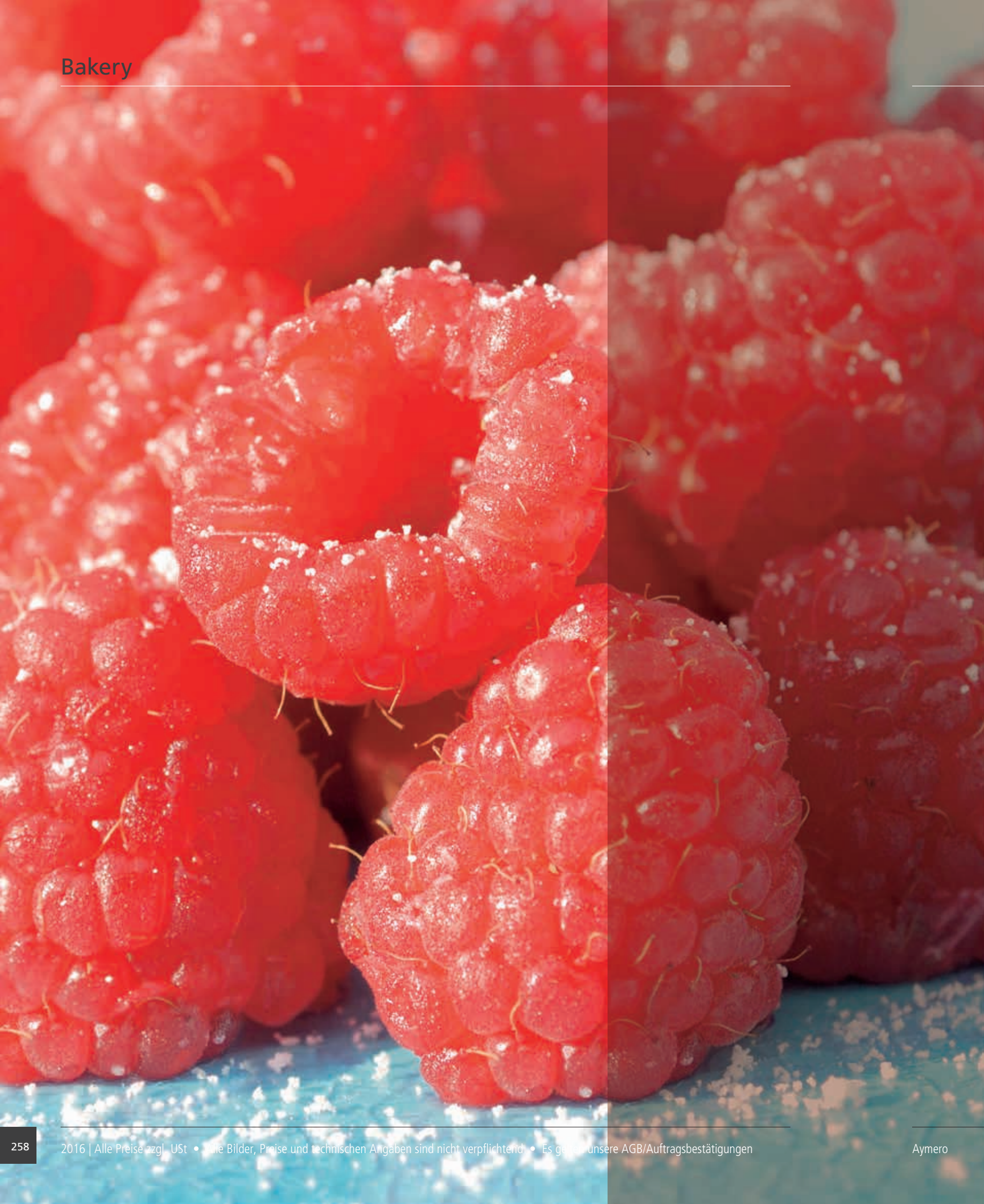

PLANETARY MIXER

- PLANEETMENGER
- PLANETEN-TEIGMASCHINE
- PLANETARY MIXER
- MIXEUR PLANÉTAIRE



	7455.1410			
	452x432x606		10	
	230V/0,45kW		110-178-355	
	56		2 kg	
	€ 816,-			



	7455.1420			
	530x496x780		20	
	230V/1,1kW		104-187-365	
	87		5 kg	
	€ 970,-			



	7455.1425			
	546x512x852		30	
	230V/1,1kW		104-187-365	
	94		6 kg	
	€ 1.695,-			

KITCHEN MACHINE

- KEUKENMACHINE
- KÜCHENMASCHINE
- KITCHEN MACHINE
- BATTEUR MELANGEUR



	7013.0130			
	210x360x400		5	
	230V/0,3kW		500	
	29			
	€ 460,-			



	7013.0132			
	232x400x420		7	
	230V/0,33kW		700	
	29			
	€ 515,-			

BOWL FOR PLANETARY MIXER

- KOM TBV PLANEETMENGER
- GELENKHÖHLE FÜR PLANETEN-TEIGMASCHINE
- BOWL FOR PLANETARY MIXER
- BOL POUR MIXEUR PLANÉTAIRE

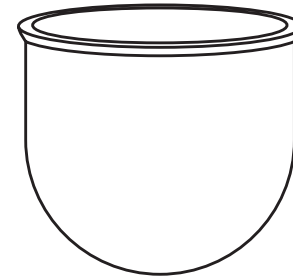

	>		€	
7455.1450	7455.1410	1	95,-	
7455.1455	7455.1420	1	160,-	
7455.1460	7455.1425	1	305,-	

DOUGH-HOOK FOR PLANETARY MIXER

- DEEGHAAK TBV PLANEETMENGER
- TEIGHAKEN FÜR PLANETEN-TEIGMASCHINE
- DOUGH-HOOK FOR PLANETARY MIXER
- PÂTECROCHET POUR PLANÉTAIRE



	>		€	
7455.1495	7455.1410	1	45,-	
7455.1497	7455.1420	1	60,-	
7455.1499	7455.1425	1	75,-	

WHISK FOR PLANETARY MIXER

- BOLGARDE TBV PLANEETMENGER
- GARDE FÜR PLANETEN-TEIGMASCHINE
- WHISK FOR PLANETARY MIXER
- FOUET POUR MIXEUR PLANÉTAIRE



	>		€	
7455.1465	7455.1410	1	45,-	
7455.1470	7455.1420	1	60,-	
7455.1475	7455.1425	1	95,-	

FLAT MIXINGARM FOR PLANETARY MIXER

- PLATTE MENGARM TBV PLANEETMENGER
- MISCHARM FÜR PLANETEN-TEIGMASCHINE
- FLAT MIXINGARM FOR PLANETARY MIXER
- BRAS À MÉLANGER POUR PLANÉTAIRE



	>		€	
7455.1480	7455.1410	1	45,-	
7455.1485	7455.1420	1	60,-	
7455.1490	7455.1425	1	95,-	

REFRIGERATED BAKERY CABINET

- BAKKERSKOELKAST
- BÄCKEREI KÜHLSCHRANK
- REFRIGERATED BAKERY CABINET
- RÉFRIGÉRATEUR PÂTISSERIE



	7450.1205			
	740x990x2010		+2/+8°C	
	624x860x1400		737	
	300V / 0,43kW		R R 134 A	
	170		✓	
	€ 2.110,-		✓	

REFRIGERATED BAKERY COUNTER

- BAKKERSKOELWERKBANK
- BÄCKEREI KÜHLTISCH
- REFRIGERATED BAKERY COUNTER
- TABLE RÉFRIGÉRÉE PÂTISSERIE



	7450.1215			
	1510x800x860		+2/+8°C	
	945x680x560		428	
	300V / 0,34kW		R R 134 A	
	155		✓	
	€ 1.849,-		✓	

REFRIGERATED BAKERY COUNTER

- BAKKERSWERKBANK
- BÄCKEREI KÜHLTISCH
- REFRIGERATED BAKERY COUNTER
- TABLE RÉFRIGÉRÉE PÂTISSERIE



	7477.0165			
	1430x800x850		0/+10°C	
	230V / 0,29kW		R R 134 A	
	140		EN 600x400	
	€ 2.118,-		✓	

FREEZED BAKERY CABINET

- BAKKERSVRIESKAST
- BÄCKEREI TIEFKÜHLSCHRANK
- FREEZED BAKERY CABINET
- CONGÉLATEUR PÂTISSERIE



	7450.1210			
	740x990x2010		-18/-22°C	
	624x860x1400		737	
	300V / 0,63kW		R R 134 A	
	161		✓	
	€ 2.499,-		✓	

REFRIGERATED BAKERY COUNTER

- BAKKERSKOELWERKBANK
- BÄCKEREI KÜHLTISCH
- REFRIGERATED BAKERY COUNTER
- TABLE RÉFRIGÉRÉE PÂTISSERIE



	7450.1220			
	2020x800x850		+2/+8°C	
	1455x680x560		635	
	300V / 0,34kW		R R 134 A	
	170		✓	
	€ 2.094,-		✓	



	7477.0170			
	1955x800x850		0/+10°C	
	230V/0,29kW		R R 134 A	
	175		EN 600x400	
	€ 2.473,-		✓	



	7477.0175			
	2480x800x850		0/+10°C	
	230V/0,38kW		R R 134 A	
	216		EN 600x400	
	€ 3.201,-		✓	

ACCESSORIES

	7450.0508			
	> 7450.1205 7450.1210		600x800	€ 45,-
	7045.0007			
	> 7450.1215 7450.1220		400x600	€ 29,-

	7451.0240			
	> 7450.1205 7450.1210		1	€ 30,-
	7451.0255			
	> 7450.1215 7450.1220		1	€ 30,-

ACCESSORIES

	7477.1030		€ 103,-
	7477.1055		€ 23,-
	7045.0007		€ 29,-
	EN	600x400	€ 29,-

Artikel 1 Toepasselijkheid van deze voorwaarden

- 1.1 In deze algemene voorwaarden wordt onder verkoper verstaan de gebruiker van de algemene voorwaarden, Gastro Point BV te Nieuwegein en de aan deze vennootschap gelieerde vennootschappen.
- 1.2 Deze algemene verkoopvoorwaarden zijn van toepassing op de totstandkoming, de inhoud en de uitvoering van alle na 1 januari 2002 gesloten overeenkomsten tussen verkoper en de wederpartij en voorts op alle door verkoper na 1 januari 2002 uitgebrachte offertes. Op voordien gesloten overeenkomsten en uitgebrachte offertes zijn de voor 1 januari 2002 geldende algemene verkoopvoorwaarden van toepassing.

Artikel 2 Offertes

- 2.1 Alle offertes van verkoper zijn vrijblijvend, tenzij deze een termijn voor aanvaarding bevatten.
- 2.2 Indien een offerte van verkoper een vrijblijvend aanbod bevat en dit door de wederpartij wordt aanvaard, heeft verkoper het recht het aanbod onvervuld na ontvangst van de aanvaarding te herroepen.
- 2.3 Alle bij een aanbod verstrekte informatie en/of specificaties inzake maten, gewichten, inhoud, capaciteit e.d. gelden altijd bij benadering. Deze informatie en/of specificaties zijn voor verkoper slechts bindend indien dit uitdrukkelijk schriftelijk is bevestigd. Alle bij een aanbod verstrekte gegevens en/of informatie blijft eigendom van verkoper en dient op eerste verzoek geretourneerd te worden.
- 2.4 De wederpartij draagt het risico van de niet-juiste uitvoering van de door hem bij zijn opdracht of latere wijzigingen van zijn opdracht opgegeven aanwijzingen en specificaties indien deze niet schriftelijk aan verkoper ter kennis zijn gebracht.
- 2.5 Eventueel later gemaakte aanvullende afspraken of wijzigingen alsmede (mondelinge) afspraken en/of toezeggingen door personeel van verkoper of namens verkoper gedaan door onze verkopers, agenten, vertegenwoordigers of andere tussenpersonen, binden verkoper slechts indien deze door verkoper schriftelijk zijn bevestigd.

Artikel 3 Prijzen

- 3.1 Tenzij anders vermeld geschieden alle prijsopgaven onder voorbehoud van prijswijziging.
- 3.2 Tenzij anders vermeld zijn de prijzen:
-gebaseerd op de tijdens de offerte respectievelijk orderdatum geldende hoogte van inkooprijzen, lonen, loonkosten, sociale- en overheidslasten, vrachten, assurantiepremies en andere kosten;
-exclusief de aanlegkosten van leidingen alsmede van hak-, breek-, metsel-, timmer-, stucadoors-, schilder-, behangers-, herstel- of andere bijkomende werkzaamheden;
-exclusief de kosten van het bedrijfsklaar opstellen daaronder begrepen de aansluiting van de apparatuur aan de leidingen;
-gebaseerd op levering af bedrijf verkoper, magazijn of andere opslagplaats;
-exclusief BTW, invoerrechten, andere belastingen, heffingen en rechten;
-exclusief de kosten van verpakkingen, in- en uitlading, vervoer en verzekering;
-vermeld in Nederlandse valuta, waarbij eventuele koerswijzigingen worden doorberekend.
- 3.3 Bij stijging van de kosten van materialen, halffabrikaten of diensten die voor de uitvoering van de overeenkomst nodig zijn, van lonen, van werkgeverslasten sociale verzekering, bij aanzienlijke wijziging in valutaverhoudingen, één en ander nadat de overeenkomst tussen partijen tot stand is gekomen, is verkoper gerechtigd de overeengekomen prijzen dienovereenkomstig te verhogen.

Artikel 4 Levering en levertijd

- 4.1 Tenzij anders overeengekomen geschiedt levering af bedrijf verkoper. Franco levering geschiedt alleen – tenzij anders is overeengekomen – bij leveringen binnen Nederland, met uitzondering van de Waddeneilanden, vanaf een factuurbedrag van € 1.000,- exclusief BTW.
- 4.2 De overeengekomen leveringstermijnen zullen nimmer zijn te beschouwen als fatale termijn, tenzij uitdrukkelijk anders is overeengekomen. Bij niet-tijdige aflevering dient de wederpartij derhalve verkoper schriftelijk in gebreke te stellen.
- 4.3 Verkoper is gerechtigd om te leveren in gedeelten (deelleveranties), welke verkoper afzonderlijk kan factureren; betaling door de wederpartij dient alsdan plaats te vinden overeenkomstig het hierna bepaalde inzake "Betaling".
- 4.4 Indien de wederpartij de zaken van de vervoerder aanneemt, geldt zulks als bewijs dat de emballage in goede staat is, tenzij door de wederpartij een aantekening van het tegendeel is vermeld op de vrachtbrief of het ontvangstbewijs.
- 4.5 Indien de zaken na het verstrijken van de overeengekomen leveringstijd door de wederpartij niet zijn afgenomen, staan deze zaken voor zijn rekening en risico te zijner beschikking opgeslagen. Na een periode van 4 weken na het verstrijken van de overeengekomen leveringstijd is verkoper gerechtigd de overeenkomst door middel van een buitengerechtelijke verklaring te ontbinden en staat het verkoper vrij deze zaken te verkopen. De hiermee gepaard gaande kosten en de eventuele minderopbrengst van deze zaken komen voor rekening van de wederpartij. De opslagkosten bedragen 8% per maand, te berekenen over de factuurwaarde.
- 4.6 Voor goederen welke op termijn (is afname voor een bepaalde datum) worden geleverd, kan verkoper betaling vooraf verlangen.

Artikel 5 Afwijkingen/stempels

- 5.1 Met betrekking tot de hoeveelheid af te leveren goederen wordt een afwijking van 5% meer of minder toegelaten.
- 5.2 Met betrekking tot goederen welke speciaal aangemaakt of bestempeld moeten worden, of op andere wijze van een merk- of kenteken moeten worden voorzien is een afwijking van 10% meer of minder toegelaten.
- 5.3 Gegevens omtrent maten, inhoud, gewicht e.d. gelden slechts bij benadering.
- 5.4 De eventueel vervaardigde stempels, gravures e.d., welke noodzakelijk zijn voor het opbrengen van een decor, naam of merkteken blijven eigendom van de betreffende fabrikant en worden niet meegeleverd. De vervaardigingskosten worden in rekening gebracht.

Artikel 6 Transport

- 6.1 Verkoper zal, de aard van de te vervoeren zaken in aanmerking nemend, de meest gebruikelijke route en de meest gebruikelijke wijze van verzending kiezen. Verkoper zal zoveel mogelijk met de wensen van koper rekening houden. Hierdoor veroorzaakte extra kosten zijn voor rekening van de wederpartij. Voor hieruit voortvloeiende vertraging is verkoper niet aansprakelijk.
- 6.2 Het transport van de goederen geschiedt in beginsel steeds voor rekening en risico van de wederpartij, zelfs dan wanneer de vervoerder vordert dat op vrachtbrieven, vervoeradressen e.d. de clause voorkomt dat alle vervoersschaden voor rekening en risico van de afzender zijn.

Artikel 7 Betaling

- 7.1 Betaling dient te geschieden netto-contant ten tijde en ter plaatse van de aflevering; verkoper is gerechtigd van de weder partij een deelbetaling bij opdracht te verlangen.
- 7.2 Indien tussen partijen schriftelijk is overeengekomen dat betaling kan geschieden door middel van storting of overmaking op een door verkoper aangewezen bank- of Postbankrekening, dient betaling te geschieden binnen acht dagen na factuur datum.
- 7.3 De wederpartij kan zich alleen dan op verrekening beroepen, indien hetzij zijn vordering door verkoper wordt erkend, hetzij de gegrondheid van die vordering op eenvoudige wijze is vast te stellen.
- 7.4 Iedere betaling van de wederpartij strekt primair ter voldoening van de door hem verschuldigde interest alsmede van de door verkoper gemaakte invorderingskosten en/of administratiekosten en worden daarna in mindering gebracht op de oudste openstaande rekening.

Artikel 8 Te late betaling

- 8.1 Indien de wederpartij de overeengekomen betalingstermijn overschrijdt is de wederpartij van rechtswege in verzuim en is verkoper gerechtigd de wettelijke rente + 2% in rekening te brengen. Voorts zal de wederpartij redelijkerwijs noodzakelijke kosten ter verkrijging van voldoening buiten rechte verschuldigd zijn, waarbij verkoper zal hanteren het incassotarif zoals dat is opgenomen in het door de Nederlandse Orde van Advocaten gehanteerde calculatieschema voor advocaten-declaraties. Indien de incasso van de vordering door verkoper in handen van een advocaat wordt gegeven, zal de wederpartij de door de advocaat aan de verkoper in rekening te brengen kosten moeten vergoeden.
- 8.2 Indien:
a. de wederpartij in verzuim is en/of
b. verkoper goede gronden heeft te vrezen, dat de wederpartij niet of niet-tijdig aan zijn betalingsverplichting zal voldoen: zal verkoper, zonder tot enige schadevergoeding gehouden te zijn, en onverminderd alle hem verder toekomende rechten, gerechtigd zijn:
a. vooruitbetaling of zekerheidstelling te verlangen;
b. de uitvoering van de koopovereenkomst geheel of gedeeltelijk op te schorten;
c. de overeengekomen betalingstermijnen, al dan niet in andere overeenkomsten, te herroepen, waardoor alle (overige) openstaande vorderingen onmiddellijk opeisbaar worden;
d. zijn verplichtingen uit alle andere overeenkomsten met koper op te schorten. Verkoper zal slechts tot de bovengenoemde maatregelen gerechtigd zijn voorzover de (gevreesde) tekortkoming van de wederpartij deze maatregelen rechtvaardigt.

Artikel 9 Overmacht

- 9.1 Tekortkomingen van verkoper in de uitvoering van de overeenkomst kunnen niet aan hem worden toegerekend, indien zij niet te wijten zijn aan zijn schuld, noch krachtens de wet, de overeenkomst of in het verkeer geldende opvattingen voor zijn rekening komen.
- 9.2 Onder overmacht wordt in ieder geval verstaan:
- de omstandigheid dat verkoper een prestatie die van belang is in verband met de door hem zelf te leveren prestatie niet, niet-tijdig of niet-behoorlijk geleverd krijgt;
- stakingen;
- storingen in het verkeer;
- overheidsmaatregelen die verkoper verhinderen zijn verplichtingen tijdig dan wel deugdelijk na te komen;
- bovenmatig ziekteverzuim.
- 9.3 Indien aflevering/afname door overmacht langer dan één maand wordt vertraagd is ieder der partijen -onder uitsluiting van verdere rechten- bevoegd de koopovereenkomst te ontbinden volgens de wet.
- 9.4 De in artikel 9.3. genoemde termijn van één maand is zoveel korter of langer naarmate één van partijen aantoont dat naar maatstaven van redelijkheid en billijkheid ontbinding op een eerder of later tijdstip gerechtvaardigd is.
- 9.5 Indien verkoper bij het intreden van de overmacht al gedeeltelijk aan zijn verplichtingen heeft voldaan, of slechts gedeeltelijk aan zijn verplichtingen kan voldoen, is hij gerechtigd het reeds geleverde c.q. het leverbare deel afzonderlijk te factureren en is de wederpartij gehouden deze factuur te voldoen als betrof het een afzonderlijk contract. Dit geldt echter niet als het reeds geleverde c.q. leverbare deel geen zelfstandige waarde heeft.

Artikel 10 - Garantie

- 10.1 Met inachtneming van hetgeen elders in deze voorwaarden is bepaald, staat verkoper in voor de deugdelijkheid alsmede de kwaliteit van de door hem geleverde, verwerkte en gebruikte materialen.
- 10.2 Indien de wederpartij genoegzaam heeft aangetoond of bewezen dat de geleverde zaak (zaken) of de geleverde materialen niet voldoen aan de in het normale verkeer daaraan te stellen eisen, zal verkoper de, als gevolg daarvan, ontstane gebreken kosteloos herstellen, tenzij verkoper verkiest de geleverde zaak (zaken) of de geleverde materialen te vervangen.
- 10.3 Garantie wordt slechts verstrekt indien en voorzover een garantie schriftelijk is overeengekomen.
- 10.4 Verkoper zal slechts uitvoering geven aan zijn garantieverplichtingen indien en voorzover de betreffende zaken en/of materialen zich binnen de landsgrenzen van Nederland bevinden.
- 10.5 Op gebruikte apparatuur wordt nimmer garantie verstrekt.
- 10.6 Glasbreuk, gebreken ontstaan door normale slijtage, onoordeelkundige behandeling of gebruik voor andere dan normale (bedrijfs) doeleinden, onvoldoende onderhoud en gebreken die zich voordoen na wijziging of reparatie door of namens de wederpartij zelf of door derden, blijven buiten de garantie.
- 10.7 Indien in het kader van de uitvoering van de garantieverplichting verkoper onderdelen vervangt, worden de te vervangen onderdelen eigendom van verkoper.
- 10.8 Indien koper het gekochte heeft meegenomen naar het buitenland is koper gehouden het geleverde op zijn kosten te (doen) bezorgen op het adres van verkoper.
- 10.9 Wanneer verkoper zijn uit deze bepaling voortvloeiende verplichtingen nakomt, heeft hij aan al zijn verplichtingen jegens de wederpartij voldaan en is hij nimmer aansprakelijk voor de door de wederpartij geleden schade

Artikel 11 - Reclames

- 11.1 De wederpartij dient binnen één dag na aflevering te onderzoeken of de afgeleverde zaken aan de verkoopovereenkomst beantwoorden.
- 11.2 De wederpartij kan er geen beroep op doen dat de afgeleverde zaken niet aan de verkoopovereenkomst beantwoorden, indien hij het onderzoek als bedoeld in artikel 11.1 nalaat of verkoper niet binnen de hierna genoemde termijnen van de gebreken in kennis stelt.
- 11.3 Zichtbare gebreken dienen binnen vijf dagen na ontvangst van de zaken, verborgen gebreken onmiddellijk nadat de wederpartij ze heeft ontdekt, doch uiterlijk 6 maanden na aflevering van de zaken schriftelijk te worden gemeld bij verkoper.
- 11.4 Klachten moeten schriftelijk worden ingediend onder vermelding van de bestelgegevens, factuur- en vrachtbrieffnummers.
- 11.5 Gereclameerde zaken mogen alleen worden teruggezonden met uitdrukkelijke schriftelijke toestemming van verkoper.
- 11.6 Ingeval van gegronde en correct ingediende klachten is verkoper, zulks te zijner keuze, rekening houdend met de belangen van de wederpartij en de aard van de klacht, verplicht tot:
- aflevering van het ontbrekende; of
 - verlening van een prijskorting; of
 - herstel van de afgeleverde zaken; of
 - vervanging van de afgeleverde zaken; of
 - restitutie van de koopprijs tegen teruggave van de afgeleverde zaken.
- 11.7 Verkoper zal deze keuze binnen een redelijke termijn na correcte melding van de klacht door de wederpartij doen en vervolgens zijn verplichtingen binnen een redelijke termijn nakomen, bij gebreke hiervan is de wederpartij bevoegd tussen bovengenoemde verplichtingen van verkoper te kiezen.
- 11.8 Wanneer verkoper zijn uit artikel 11.6 of 11.7 voortvloeiende verplichtingen nakomt, heeft hij aan al zijn verplichtingen jegens de wederpartij voldaan en is hij nimmer aansprakelijk voor de door de wederpartij geleden schade.

Artikel 12 - Aansprakelijkheid

- 12.1 Verkoper is jegens koper uitsluitend op de volgende wijze aansprakelijk:
- Voor schade als gevolg van een gebrek in het geleverde is verkoper slechts aansprakelijk voorzover hij hiertegen is verzekerd, dan wel gezien de in de branche geldende gebruiken, verzekerd had behoren te zijn, tot maximaal het bedrag van de verzekeringsuitkering;
 - Voor schade als gevolg van niet tijdige aflevering is verkoper niet aansprakelijk;
 - Voor schade in andere gevallen is de aansprakelijkheid van verkoper beperkt tot de door de wederpartij geleden schade die het rechtstreeks en uitsluitend gevolg is van schuld van verkoper. Deze schade komt slechts voor vergoeding in aanmerking indien verkoper hiertegen verzekerd is, danwel redelijkerwijs, gezien de in de branche geldende gebruiken, verzekerd had behoren te zijn, tot maximaal het bedrag van de verzekeringsuitkering;
 - Verkoper is eveneens aansprakelijk als de schade is veroorzaakt door opzet of grove schuld van verkoper of zijn leidinggevende ondergeschikten.
- 12.2 Bedrijfschade (bedrijfsstoring, het stilliggen van het bedrijf, derving van inkomsten en dergelijke) door welke oorzaak ook ontstaan, komt nimmer voor vergoeding in aanmerking. De wederpartij dient zich desgewenst tegen deze schade te verzekeren.
- 12.3 De door verkoper te vergoeden schade zal worden gematigd wanneer de door de wederpartij te betalen prijs niet in verhouding staat tot de door de wederpartij geleden schade.
- 12.4 De wederpartij is zelf aansprakelijk voor alle schade ten gevolge van verlies, diefstal, brand of beschadiging van de door verkoper afgeleverde zaken vanaf het moment van aflevering.

Artikel 13 - Eigendomsvoorbehoud

- 13.1 De afgeleverde zaken worden eerst eigendom van de wederpartij als deze al datgene heeft gedaan wat verkoper uit hoofde van alle (eerdere of latere) verkoopovereenkomsten met de wederpartij en/of door verkoper in dat kader verrichte diensten of werkzaamheden te vorderen mocht hebben of mocht krijgen, waaronder begrepen vorderingen tot schadevergoeding wegens het niet nakomen van de hier bedoelde overeenkomsten, waaronder rente en kosten alsmede de in artikel 13.7 gefixeerde schadevergoeding.
- 13.2 De wederpartij is binnen redelijke grenzen verplicht zijn medewerking te verlenen bij alle maatregelen die verkoper ter bescherming van de afgeleverde zaken en/of zijn eigendomsrecht op die zaken wil treffen.
- 13.3 Indien derden enig recht op de onder eigendomsvoorbehoud afgeleverde zaken willen vestigen of doen gelden, is de wederpartij verplicht verkoper onmiddellijk hiervan schriftelijk op de hoogte te stellen.
- 13.4 Zolang het eigendomsvoorbehoud geldt is de wederpartij uitsluitend bevoegd tot eigen be- /verwerking of doorlevering van de afgeleverde zaken in de normale uitoefening van zijn bedrijf.
- 13.5 Na be-/verwerking van bedoelde zaken wordt verkoper (mede)eigenaar van de daaruit gevormde of mede daaruit gevormde zaken en zal de wederpartij deze zaken automatisch gaan houden voor verkoper.
- 13.6 Indien verkoper niettegenstaande het bepaalde in artikel 13.5. niet de eigendom van de door de wederpartij gevormde zaken verkrijgt, zal de wederpartij op eerste verzoek van verkoper alle vereiste medewerking verlenen die nodig is voor het vestigen van een al dan niet bezitloos pandrecht op de betreffende zaken ten behoeve van verkoper.
- 13.7 Indien de wederpartij zijn betalingsverplichtingen niet of niet-tijdig nakomt of indien gegronde vrees bestaat dat dit zal gebeuren, is verkoper gerechtigd afgeleverde zaken waarop het in artikel 13 lid 1 bedoelde eigendomsvoorbehoud rust, de in artikel 13.5. bedoelde zaken, alsmede de in artikel 13.6. bedoelde zaken waarop het bezitloos pandrecht rust bij de wederpartij of derden, die de zaak voor de wederpartij houden, weg te halen of weg te doen halen. De wederpartij is verplicht hiervoor al zijn medewerking te verlenen op straffe van een boete van 10% van het door hem aan verkoper verschuldigde, met een minimum van € 500, per dag of gedeelte daarvan dat koper in gebreke is met de nakoming van deze verplichting.

Artikel 14 - Toepasselijk recht

- 14.1 De overeenkomsten tussen verkoper en wederpartij worden uitsluitend beheerst door het Nederlandse recht, met uitsluiting van de eenvormige wetten inzake de Internationale Koop van Roerende Lichamelijke Zaken.
- 14.2 Ter zake van de uitleg van internationale handelstermijnen zijn de "Incoterms", zoals samengesteld door de Internationale Kamer van Koophandel te Parijs van toepassing.

Artikel 15 - Geschillen

- 15.1 Alle geschillen zullen worden beslecht door de bevoegde burgerlijke rechter, zulks met inachtneming van de ter zake vigerende competentieregels.

ALLGEMEINE BEDINGUNGEN Combisteel Orgalime S 2012

für die LIEFERUNG VON MECHANISCHEN, ELEKTRISCHEN UND ELEKTRONISCHEN ERZEUGNISSEN - Brüssel, März 2012

PRÄAMBEL

1. Diese Allgemeinen Bedingungen gelten, wenn sie die Parteien schriftlich oder anderweitig vereinbaren. Änderungen oder Abweichungen davon sind schriftlich zu vereinbaren.

BEGRIFFSBESTIMMUNGEN

2. In diesen Allgemeinen Bedingungen sind die nachstehenden Begriffe wie folgt zu verstehen:

- "Vertrag": die zwischen den Parteien schriftlich vereinbarte Übereinkunft über die Lieferung des Liefergegenstandes sowie aller Anhänge, einschließlich ggf. Vereinbarter, schriftlicher Ergänzungen und Zusätze zu den vorgenannten Unterlagen.

- "Grobe Fahrlässigkeit": ein Handeln oder Unterlassen, bei dem die betreffende Partei entweder die verkehrsübliche Sorgfalt im Hinblick auf den Eintritt schwerwiegender Folgen nicht walten ließ, die eine verantwortungsbewusste Vertragspartei normalerweise vorausgesehen hätte, oder bei dem die betreffende Partei bewusst die Folgen eines solchen Handelns oder Unterlassens außer Acht gelassen hat.

- "Schriftlich": mittels Schriftstück, das von den Parteien unterzeichnet ist, oder mittels Schreiben, Fax, Email oder anderer, von den Parteien vereinbarter Form.

- "Liefergegenstand": die gemäß dem Vertrag zu liefernden Waren, einschließlich Software und Dokumentation.

PRODUKTINFORMATION

3. Die in allgemeinen Produktdokumentationen und Preislisten enthaltenen Angaben und Informationen sind nur soweit verbindlich, als der Vertrag ausdrücklich und schriftlich auf sie Bezug nimmt.

ZEICHNUNGEN UND TECHNISCHE INFORMATIONEN

4. Stellt eine Partei der anderen Partei Zeichnungen und technische Unterlagen über den Liefergegenstand oder seine Herstellung vor oder nach Vertragsschluss zur Verfügung, bleiben diese Eigentum der sie vorlegenden Partei. Erhält eine Partei Zeichnungen, technische Unterlagen oder andere technische Informationen, so darf sie diese ohne die Zustimmung der anderen Partei nicht für einen anderen Zweck nutzen, als für den sie geliefert wurden. Sie dürfen nicht ohne Zustimmung der vorlegenden Partei für andere Zwecke genutzt, kopiert, reproduziert, an Dritte weitergegeben oder bekannt gegeben werden.

5. Der Lieferer stellt spätestens zum Zeitpunkt der Lieferung kostenlos Angaben und Zeichnungen zur Verfügung, die es dem Besteller ermöglichen, den Liefergegenstand aufzustellen, in Betrieb zu nehmen, zu unterhalten und zu warten. Die vereinbarte Anzahl solcher Anleitungen und Zeichnungen ist zu übergeben, jedoch mindestens jeweils ein Exemplar. Der Lieferer ist nicht zur Beschaffung von Werkstattzeichnungen für den Liefergegenstand oder für Ersatzteile verpflichtet.

ABNAHMEPRÜFUNGEN

6. In dem Vertrag vereinbarte Abnahmeprüfungen werden mangels abweichender Vereinbarung am Herstellungsort während der normalen Arbeitszeit durchgeführt. Enthält der Vertrag keine Bestimmungen über technische Anforderungen, so ist für die Prüfungen die im Herstellungsland bestehende allgemeine Praxis des betreffenden Industriezweiges maßgeblich.

7. Der Lieferer muss den Besteller schriftlich so rechtzeitig von der Abnahmeprüfung verständigen, dass dieser bei den Prüfungen vertreten werden kann. Wird der Besteller nicht vertreten, so erhält er vom Lieferer ein Prüfungsprotokoll, dessen Richtigkeit er nicht mehr bestreiten kann.

8. Erweist sich der Liefergegenstand bei den Abnahmeprüfungen als vertragswidrig, so hat der Lieferer unverzüglich jeglichen Mangel zu beheben, um den vertragsgemäßen Zustand des Liefergegenstandes herzustellen. Der Besteller kann eine Wiederholung der Prüfungen nur in Fällen wesentlicher Mängel verlangen.

9. Der Lieferer trägt alle Kosten für die am Herstellungsort durchgeführten Abnahmeprüfungen. Der Besteller hat jedoch für seine Vertreter sämtliche in Verbindung mit den Prüfungen entstandenen Reise- und Lebenshaltungskosten zu tragen.

LIEFERUNG. GEFAHRÜBERGANG

10. Die vereinbarten Lieferklauseln sind nach den bei Vertragsschluss geltenden INCOTERMS® auszulegen. Mangels besonderer Lieferklausel im Vertrag gilt der Liefergegenstand als "Frei Frachtführer" (FCA) an dem vom Lieferer benannten Ort geliefert. Verpflichtet sich der Lieferer im Falle einer FCA-Lieferung auf Verlangen des Bestellers dazu, den Liefergegenstand an seinen Bestimmungsort zu versenden, so geht die Gefahr spätestens zu dem Zeitpunkt über, an dem der Liefergegenstand an den ersten Spediteur übergeben wird. Teillieferungen sind mangels abweichender Vereinbarung nicht gestattet.

LIEFERFRIST. VERZÖGERUNGEN

11. Haben die Parteien statt eines festen Liefertermins eine Frist vereinbart, innerhalb der die Lieferung zu erfolgen hat, dann beginnt die Frist mit Abschluss des Vertrages sowie der Erfüllung aller anderen vereinbarten Vorbedingungen durch den Besteller, wie Erledigung offizieller Formalitäten, Begleichung der bei Vertragsschluss fälligen Zahlungen und Sicherungsmittel.

12. Kann der Lieferer absehen, dass er den Liefergegenstand nicht innerhalb der Lieferfrist liefern können wird, so hat er den Besteller unverzüglich und schriftlich davon in Kenntnis zu setzen, ihm die Gründe hierfür mitzuteilen sowie nach Möglichkeit den voraussichtlichen Lieferzeitpunkt zu nennen. Unterlässt der Lieferer eine solche Mitteilung, ist der Besteller berechtigt, Ersatz aller weiteren Kosten zu verlangen, die ihm aufgrund des Umstandes entstehen, dass er eine solche Mitteilung nicht erhalten hat.

13. Verzögert sich die Lieferung durch einen in Ziffer 41 aufgeführten Umstand oder durch ein Handeln oder Unterlassen des Bestellers, wozu auch die Einstellung der Leistung nach Ziffer 21 und Ziffer 44 oder andere auf den Besteller zurückzuführende Umstände zählen, so ist der Lieferer berechtigt, die Lieferfrist unter Berücksichtigung aller im Einzelfall vorliegenden Umständen im erforderlichen Maße zu verlängern. Diese Bestimmung gilt unabhängig davon, ob der Grund für die Verzögerung vor oder nach dem vereinbarten Liefertermin eintritt.

14. Wird der Liefergegenstand nicht zum Liefertermin geliefert, so hat der Besteller ab dem Zeitpunkt Anspruch auf Zahlung eines pauschalierten Schadenersatzes, zu dem die Lieferung hätte erfolgen müssen.

Der pauschalierte Schadenersatz ist auf 0,5 v.H. des Kaufpreises für jede angefangene Woche der Verzögerung festgesetzt. Der pauschalierte Schadenersatz kann 7,5 v.H. des Kaufpreises nicht überschreiten.

Verzögert sich nur ein Teil des Liefergegenstandes, so wird der pauschalierte Schadenersatz aufgrund des Kaufpreises bestimmt, der dem Teil des Liefergegenstandes entspricht, der durch die Verzögerung nicht wie von den Parteien vorgesehen genutzt werden kann.

Der pauschalierte Schadenersatz wird mit der schriftlichen Geltendmachung des Bestellers fällig, jedoch nicht bevor die Gesamtlieferung abgeschlossen oder der Vertrag nach Ziffer 15 beendet worden ist.

Der Besteller verliert seinen Anspruch auf Zahlung des pauschalierten Schadenersatzes, wenn er diesen nicht schriftlich innerhalb von sechs Monaten ab dem Zeitpunkt geltend macht, zu dem die Lieferung hätte erfolgen sollen.

15. Ist der Besteller wegen der Länge der Verzögerungsberechtigt, den Höchstbetrag an pauschaliertem Schadenersatz nach Ziffer 14 zu fordern, und ist der Liefergegenstand noch nicht geliefert, so kann er dem Lieferer schriftlich eine letzte angemessene Lieferfrist von mindestens einer Woche setzen.

Liefert der Lieferer nicht innerhalb dieser letzten Frist aus einem Grund, der nicht auf den Besteller zurückzuführen ist, so kann der Besteller durch schriftliche Mitteilung an den Lieferer von dem Vertrag hinsichtlich desjenigen Teiles des Liefergegenstandes zurücktreten, welcher aufgrund der Lieferverzögerung durch den Lieferer nicht wie von den Parteien vorgesehen genutzt werden kann.

Tritt der Besteller von dem Vertrag zurück, so hat er einen Anspruch auf Entschädigung für den ihm aufgrund der Verzögerung durch den Lieferer entstehenden Schaden, einschließlich etwaiger indirekter Schäden oder Folgeschäden. Die Gesamthöhe der Entschädigung, einschließlich des pauschalierten Schadenersatzes nach Ziffer 14, darf 15 v.H. des Teil-Kaufpreises nicht überschreiten, der dem Teil des Liefergegenstandes entspricht, hinsichtlich dessen der Besteller von dem Vertrag zurückgetreten ist.

Der Besteller ist weiterhin berechtigt, den Vertrag durch schriftliche Mitteilung an den Verkäufer zu beenden, wenn es sich aus den Umständen zweifelsfrei ergibt, dass sich die Lieferung um einen Zeitraum verzögern wird, aufgrund dessen dem Besteller der Höchstsatz an Schadenersatz gemäß Ziffer 14 zustünde. Wird der Vertrag aus diesem Grund beendet, steht dem Besteller der Höchstsatz an pauschaliertem Schadenersatz sowie eine Entschädigung gemäß dem dritten Absatz dieser Ziffer 15 zu.

16. Weitergehende Ansprüche über den pauschalierten Schadenersatz nach Ziffer 14 und den Rücktritt von dem Vertrag mit begrenzter Entschädigung nach Ziffer 15 hinaus können seitens des Bestellers im Falle der Verzögerung durch den Lieferer nicht geltend gemacht werden. Alle anderen Ansprüche gegenüber dem Lieferer im Hinblick auf Verzögerung sind ausgeschlossen, sofern nicht grobe Fahrlässigkeit seitens des Lieferers vorliegt.

17. Kann der Besteller absehen, dass ihm die Annahme des Liefergegenstandes zum Liefertermin unmöglich sein wird, so hat er den Lieferer unverzüglich schriftlich davon in Kenntnis zu setzen, ihm den Grund dafür mitzuteilen sowie ihm nach Möglichkeit den Zeitpunkt zu nennen, zu dem er die Lieferung annehmen kann.

Nimmt der Besteller die Lieferung zum Liefertermin nicht an, so hat er dennoch den Teil des zum Liefertermin fälligen Kaufpreises zu entrichten, als ob die Lieferung zum Liefertermin erfolgt wäre. Der Lieferer hat für die Einlagerung des Liefergegenstandes auf Kosten und Gefahr des Bestellers zu sorgen. Weiterhin hat der Lieferer auf Verlangen des Bestellers den Liefergegenstand auf Kosten des Bestellers zu versichern.

18. Beruht die Nichtannahme durch den Besteller nicht auf einem in Ziffer 41 vorgesehenen Umstand, kann der Lieferer den Besteller schriftlich zur Annahme der Lieferung innerhalb einer angemessenen letzten Frist auffordern.

Nimmt der Besteller aus einem Grund, der nicht auf den Lieferer zurückzuführen ist, die Lieferung nicht innerhalb einer solchen Frist an, kann der Lieferer schriftlich ganz oder teilweise von dem Vertrag zurücktreten. Der Lieferer hat dann Anspruch auf Ersatz des ihm durch den Verzug des Bestellers entstandenen Schadens, einschließlich indirekter Schäden und Folgeschäden. Die Gesamthöhe der Entschädigung darf den Kaufpreis nicht überschreiten, der dem Teil des Liefergegenstandes entspricht, hinsichtlich dessen der Vertrag aufgelöst wird.

ZAHLUNGEN

19. Zahlungen haben innerhalb einer Frist von 30 Tagen ab Rechnungsdatum zu erfolgen.

Mangels abweichender Vereinbarung ist ein Drittel des Kaufpreises bei Vertragsschluss fällig und ein Drittel, nachdem der Lieferer dem Besteller die Versandbereitschaft des Liefergegenstandes oder wesentlicher Teile des Liefergegenstandes erklärt hat. Der verbleibende Teil des Kaufpreises ist bei Abschluss der Gesamtlieferung zahlbar.

20. Ungeachtet des verwendeten Zahlungsmittels gilt die Zahlung erst dann als erfolgt, wenn der fällige Betrag unwiderruflich dem Konto des Lieferers gutgeschrieben wird.

21. Ist der Besteller mit seinen Zahlungen im Rückstand, so kann der Lieferer vom Tag der Fälligkeit an Verzugszinsen sowie Ersatz der Betriebskosten fordern. Mangels abweichender Vereinbarung der Parteien gilt ein Zinssatz von 8 Prozentpunkten über dem Satz der Spitzenrefinanzierungsfazilität der Europäischen Zentralbank als vereinbart. Die zu ersetzenden Betriebskosten betragen 1 v.H. des Betrages, für den Verzugszinsen fällig werden.

Im Falle verzögerter Zahlung oder im Falle einer nicht fristgerechten Gestellung einer vereinbarten Sicherheit durch den Besteller kann der Lieferer, nach schriftlicher Mitteilung an den Besteller, die Erfüllung seiner eigenen Verpflichtungen bis zum Erhalt der Zahlungen bzw. bis zur Gestellung der Sicherheit einstellen.

Ist der Besteller mit seinen fälligen Zahlungen mehr als drei Monate im Rückstand, so kann der Lieferer durch schriftliche Mitteilung an den Besteller vom Vertrag zurücktreten und, zusätzlich zu den Zinsen und Betriebskosten gemäß dieser Ziffer, vom Besteller Ersatz des ihm entstandenen Schadens verlangen. Ein solcher Schadenersatz darf den vereinbarten Kaufpreis nicht überschreiten.

EIGENTUMSVORBEHALT

22. Der Liefergegenstand bleibt bis zur vollständigen Bezahlung Eigentum des Lieferers, sofern ein solcher Eigentumsvorbehalt nach dem jeweiligen Recht wirksam ist.

Auf Verlangen des Lieferers hat ihn der Besteller bei seinen Bemühungen umfassend zu unterstützen, das Eigentumsrecht des Lieferers an dem Liefergegenstand zu schützen.

Der Eigentumsvorbehalt berührt nicht die Bestimmungen über den Gefahrübergang nach Ziffer 10.

HAFTUNG FÜR MÄNGEL

23. Nach Maßgabe der Ziffern 24-39 ist der Lieferer verpflichtet, sämtliche Mängel bzw. Abweichungen zu beheben (nachfolgend „Mangel/Mängel“ genannt), die auf einem Fehler der Konstruktion, des Materials oder der Ausführung beruhen.

24. Der Lieferer haftet nicht für Mängel, die auf vom Besteller beigestellten Materialien oder einer vom Besteller vorgeschriebenen oder näher bestimmten Konstruktion beruhen.

25. Der Lieferer haftet nur für solche Mängel, die unter den vertraglich vorgesehenen Betriebsbedingungen und bei ordnungsgemäßem Gebrauch des Liefergegenstandes auftreten.

26. Der Lieferer haftet nicht für Mängel, die auf nach dem Gefahrübergang eintretende Umstände zurückzuführen sind, wie z.B. Mängel aufgrund von schlechter Instandhaltung, unsachgemäßer Aufstellung, fehlerhafter Reparatur durch den Besteller oder auf Änderungen ohne schriftliche Zustimmung des Lieferers. Der Lieferer haftet weder für normale Abnutzung noch für Verschlechterung.

27. Die Haftung des Lieferers ist auf Mängel beschränkt, die innerhalb eines Jahres nach der Lieferung auftreten. Übersteigt die Nutzung des Liefergegenstandes den vereinbarten Rahmen, verkürzt sich die Frist angemessen.

28. Wird ein Mangel in einem Teil des Liefergegenstandes behoben, haftet der Lieferer ein Jahr für Mängel der gelieferten Ersatzteile oder reparierten Teile zu den gleichen Bedingungen wie für den ursprünglichen Liefergegenstand. Für alle anderen Teile des Liefergegenstandes verlängert sich die unter Ziffer 27 genannte Frist lediglich soweit und solange die durch den Mangel verursachte Nutzungsunterbrechung des Liefergegenstandes andauert.

29. Der Besteller hat einen auftretenden Mangel unverzüglich schriftlich gegenüber dem Lieferer zu rügen. Eine solche Mängelrüge hat in jedem Fall innerhalb von zwei Wochen nach Ablauf der unter Ziffer 27 bestimmten Frist bzw. der verlängerten Frist(en) gemäß Ziffer 28 zu erfolgen.

Die Rüge hat den Mangel zu beschreiben. Rügt der Besteller den Mangel gegenüber dem Lieferer nicht schriftlich innerhalb der in Absatz 1 dieser Ziffer festgelegten Fristen, verliert der Besteller sein Recht auf Behebung des Mangels.

Könnte der Mangel Schäden verursachen, hat der Besteller den Lieferer unverzüglich schriftlich in Kenntnis zu setzen. Der Besteller trägt die Gefahr für Schäden am Liefergegenstand, die sich aus einem Unterlassen der Mitteilung ergeben. Der Besteller hat die zur Schadensbegrenzung angemessenen Maßnahmen zu ergreifen und insoweit den Anweisungen des Lieferers Folge zu leisten.

30. Nach Erhalt der Mängelrüge nach Ziffer 29 hat der Lieferer den Mangel unverzüglich und auf seine Kosten gemäß Ziffern 23 - 39 zu beheben. Die Mängelbeseitigung ist zeitlich so festzulegen, dass die Abläufe des Bestellers nicht unnötig beeinträchtigt werden. Der Mangel ist grundsätzlich am Standort des Liefergegenstandes zu beheben, sofern der Lieferer nicht die Zusendung in sein Werk oder an einen anderen von ihm benannten Ort für geeigneter hält.

Lässt sich der Mangel durch Ersatz oder Reparatur eines mangelhaften Teiles beheben und bedarf der Aus- und Einbau des Teiles keiner besonderen Fachkenntnisse, kann der Lieferer den Versand des mangelhaften Teiles in sein Werk oder an einen anderen von ihm benannten Ort verlangen. In diesem Fall endet die Verpflichtung des Lieferers bezüglich des Mangels mit der Lieferung des ordnungsgemäß reparierten oder ausgetauschten Teiles an den Besteller.

31. Der Besteller hat auf eigene Kosten dem Lieferer den Zugang zu dem Liefergegenstand zu ermöglichen und für etwaige Eingriffe in Bezug auf Ausrüstungsgegenstände, die nicht zu dem Liefergegenstand gehören, Sorge zu tragen, soweit dies für die Behebung des Mangels notwendig ist.

32. Mangels abweichender Vereinbarung erfolgt der notwendige Transport des Liefergegenstandes oder der Teile des Liefergegenstandes zum und vom Lieferer im Zusammenhang mit der Behebung von Mängeln, für die der Lieferer haftet, auf Gefahr und Kosten des Lieferers. Der Besteller hat bei einem solchen Transport die Anweisungen des Lieferers zu befolgen.

33. Mangels abweichender Vereinbarung hat der Besteller alle zusätzlichen Kosten zu tragen, die dem Lieferer bei der Behebung des Mangels aufgrund der Tatsache entstehen, dass der Standort des Liefergegenstandes von dem bei Vertragsschluss als Ort der Lieferung durch den Lieferer an den Besteller angegebenen Bestimmungsort oder - wenn kein Bestimmungsort angegeben war - von dem Lieferort abweicht.

34. Ersetzte mangelhafte Teile sind dem Lieferer zur Verfügung zu stellen und gehen in sein Eigentum über.

35. Hat der Besteller den Mangel nach Ziffer 29 gerügt und ist kein Mangel festzustellen, für den der Lieferer haftet, so hat der Besteller dem Lieferer die Kosten zu ersetzen, die dem Lieferer durch eine solche Rüge entstehen.

36. Kommt der Lieferer seiner Verpflichtung nach Ziffer 30 nicht nach, so kann der Besteller dem Lieferer schriftlich eine letzte, angemessene Frist von mindestens einer Woche setzen, innerhalb derer der Lieferer seinen Verpflichtungen nachzukommen hat.

Erfüllt der Lieferer seine Verpflichtungen innerhalb dieser letzten Frist nicht, kann der Besteller die notwendigen Reparaturen selbst oder von einem Dritten auf Kosten und Gefahr des Lieferers vornehmen lassen.

Wurde die Reparatur erfolgreich vom Besteller oder einem Dritten durchgeführt, so sind alle Ansprüche des Bestellers hinsichtlich dieses Mangels gegenüber dem Lieferer mit Erstattung der dem Besteller entstandenen angemessenen Kosten abgegolten.

37. Schlägt eine gemäß Ziffer 36 durchgeführte Reparatur fehl,

a) so kann der Besteller eine dem geminderten Wert des Liefergegenstandes entsprechende Minderung des Kaufpreises verlangen, wobei die Minderung in keinem Fall mehr als 15 v.H. des Kaufpreises überschreiten darf; oder

b) ist der Mangel so grundlegend, dass der Besteller sein Interesse an dem Vertrag in Bezug auf den Liefergegenstand oder einen wesentlichen Teil davon verliert, so kann der Besteller nach schriftlicher Mitteilung an den Lieferer in Bezug auf den

Teil des Liefergegenstandes vom Vertrag zurücktreten, der aufgrund des Mangels nicht wie von den Parteien vorgesehen genutzt werden kann. Der Besteller hat dann Anspruch auf Ersatz seiner Einbußen, Kosten und Schäden bis zu einem Betrag von maximal 15 v.H. des Teil-Kaufpreises, der dem Teil des Liefergegenstandes entspricht, hinsichtlich dessen der Besteller von dem Vertrag zurückgetreten ist.

38. Unbeschadet der Bestimmungen nach Ziffer 23-37 ist die Haftung des Lieferers für Mängel an jeglichem Teil des Liefergegenstandes auf ein Jahr ab Ende der in Ziffer 27 festgelegten Haftungsdauer bzw. dem Ende einer etwaig von den Parteien vereinbarten, abweichenden Haftungsdauer beschränkt.

39. Vorbehaltlich der Bestimmungen nach Ziffer 23-38 haftet der Lieferer nicht für Mängel. Dies gilt für jeden durch den Mangel verursachten Schaden, einschließlich Produktionsstillstand, entgangenen Gewinn und andere indirekte Schäden. Die Haftungsbeschränkung des Lieferers gilt nicht bei grober Fahrlässigkeit.

HAFTUNGSTEILUNG FÜR DURCH DEN LIEFERGEGENSTAND VERURSACHTE SCHÄDEN

40. Der Lieferer haftet nicht für Sachschäden, die vom Liefergegenstand nach erfolgter Lieferung verursacht werden, wenn der Liefergegenstand im Besitz des Bestellers ist. Weiterhin übernimmt der Lieferer keinerlei Haftung für Schäden an den vom Besteller gefertigten Erzeugnissen oder an Waren, die ein vom Besteller gefertigtes Erzeugnis beinhalten.

Wird der Lieferer von einem Dritten für Sachschäden im Sinne des vorangegangenen Absatzes zur Haftung herangezogen, so hat der Besteller den Lieferer zu entschädigen, zu verteidigen und schadlos zu halten.

Macht ein Dritter einen in dieser Ziffer beschriebenen Anspruch gegen eine der Parteien geltend, so hat diese Partei die andere Partei hiervon unverzüglich und schriftlich in Kenntnis zu setzen.

Der Lieferer und der Besteller sind verpflichtet, sich jeweils von einem Gericht oder Schiedsgericht vorladen zu lassen, das die gegen eine der Parteien erhobenen Schadenersatzansprüche wegen des angeblich durch den Liefergegenstand verursachten Schadens prüft. Die Haftung zwischen dem Lieferer und dem Besteller unterliegt jedoch den Bestimmungen der Ziffer 46.

Die Haftungsbeschränkung des Lieferers gemäß dem ersten Absatz dieser Ziffer gilt nicht im Falle grober Fahrlässigkeit durch den Lieferer.

HÖHERE GEWALT

41. Jede Partei ist berechtigt, ihre vertraglichen Pflichten insoweit einzustellen, wie diese Erfüllung durch höhere Gewalt unmöglich gemacht oder unangemessen erschwert werden; hierzu zählen: Arbeitskonflikte und alle vom Parteiwillen unabhängige Umstände wie Brand, Krieg, allgemeine Mobilmachung, Aufstand, Requisition, Beschlagnahme, Embargo, Einschränkungen des Energieverbrauchs, Devisen- und Exportbeschränkungen, Epidemien, Naturkatastrophen, extreme Naturereignisse, terroristische Akte sowie mangelhafte oder verzögerte Lieferungen durch Subunternehmer aufgrund der in dieser Ziffer aufgeführten Umstände.

Ein vor oder nach Vertragsschluss eintretender Umstand gemäß dieser Ziffer berechtigt nur insoweit zur Einstellung, als seine Auswirkungen auf die Erfüllung des Vertrages bei Vertragsschluss noch nicht vorhersehbar waren.

42. Die sich auf höhere Gewalt berufende Partei hat die andere Partei unverzüglich und schriftlich vom Eintritt und dem Ende eines solchen Umstandes in Kenntnis zu setzen. Unterlässt eine Partei eine solche Mitteilung, ist die andere Partei berechtigt, Ersatz aller zusätzlichen Kosten zu verlangen, die ihr aufgrund des Umstandes entstehen, dass sie eine solche Mitteilung nicht erhalten hat.

Hindert höhere Gewalt den Besteller an der Erfüllung seiner Pflichten, hat er den Lieferer für aufgewendete Kosten zur Sicherung und zum Schutz des Liefergegenstandes zu entschädigen.

43. Ungeachtet aller in diesen Allgemeinen Bedingungen festgelegten Auswirkungen hat jede Partei das Recht, von dem Vertrag durch schriftliche Mitteilung an die andere Partei zurückzutreten, falls die Einstellung der Erfüllung des Vertrages nach Ziffer 41 länger als sechs Monate andauert.

VORHERSEHBARE NICHTERFÜLLUNG

44. Unbeschadet anders lautender Regelungen in diesen Allgemeinen Bedingungen bezüglich Einstellung der Erfüllung, hat jede Partei das Recht, die Erfüllung ihrer vertraglichen Pflichten einzustellen, wenn sich aus den Umständen zweifelsfrei ergibt, dass die andere Partei ihre Pflichten nicht erfüllen wird. Eine die Erfüllung ihrer vertraglichen Pflichten einstellende Partei hat die andere Partei unverzüglich und schriftlich davon in Kenntnis zu setzen.

FOLGESCHÄDEN

45. Vorbehaltlich abweichender Bestimmungen in diesen Allgemeinen Bedingungen ist die Haftung der einen Partei gegenüber der anderen Partei für Produktionsstillstand, entgangenen Gewinn, Nutzungsausfall, Vertragseinbußen oder jeden anderen Folgeschaden oder indirekten Schaden ausgeschlossen.

STREITIGKEITEN UND ANWENDBARES RECHT

46. Alle sich in Verbindung mit oder aus dem Vertrag ergebenden Streitigkeiten werden nach der Schiedsordnung der Internationalen Handelskammer von einem oder mehreren Schiedsrichter/n endgültig entschieden, der/die gemäß dieser Ordnung ernannt wird/werden.

47. Der Vertrag unterliegt dem materiellen Recht des Landes des Lieferers.

Dies ist eine Orgalime-Veröffentlichung. Orgalime ist der europäische Verband der Maschinenbau-, Elektro-, und Metallverarbeitungsindustrie.

Alle Rechte vorbehalten ©

Editeur responsable : Adrian Harris, Director General

ORGALIME – The European Engineering Industries Association

Diamant Building, Boulevard A Reyers 80, B-1030 Brussels

Tel: +32 2 706 82 35 – Fax: +32 2 706 82 50 – secretariat@orgalime.org – www.orgalime.org

1. These General Conditions shall apply when the parties agree In Writing or otherwise thereto. Any modifications of or deviations from them must be agreed In Writing.

DEFINITIONS

2. In these General Conditions the following terms shall have the meanings hereunder assigned to them:

- "Contract": the agreement In Writing between the parties concerning supply of the Product and all appendices, including agreed amendments and additions In Writing to the said documents;
- "Gross Negligence": an act or omission implying either a failure to pay due regard to serious consequences, which a conscientious contracting party would normally foresee as likely to ensue, or a deliberate disregard of the consequences of such an act or omission;
- "In Writing": communication by document signed by both parties or by letter, fax, electronic mail and by such other means as are agreed by the parties;
- "the Product": the object(s) to be supplied under the Contract, including software and documentation.

PRODUCT INFORMATION

3. All information and data contained in general product documentation and price lists shall be binding only to the extent that they are by reference In Writing expressly included in the Contract.

DRAWINGS AND TECHNICAL INFORMATION

4. All drawings and technical documents relating to the Product or its manufacture submitted by one party to the other, prior or subsequent to the formation of the Contract, shall remain the property of the submitting party.

Drawings, technical documents or other technical information received by one party shall not, without the consent of the other party, be used for any other purpose than that for which they were provided. They may not, without the consent of the submitting party, otherwise be used or copied, reproduced, transmitted or communicated to a third party.

5. The Supplier shall, not later than at the date of delivery, provide free of charge information and drawings which are necessary to permit the Purchaser to install, commission, operate and maintain the Product. Such information and drawings shall be supplied in the number of copies agreed upon or at least one copy of each. The Supplier shall not be obliged to provide manufacturing drawings for the Product or for spare parts

ACCEPTANCE TESTS

6. Acceptance tests provided for in the Contract shall, unless otherwise agreed, be carried out at the place of manufacture during normal working hours. If the Contract does not specify the technical requirements, the tests shall be carried out in accordance with general practice in the appropriate branch of industry concerned in the country of manufacture.

7. The Supplier shall notify the Purchaser In Writing of the acceptance tests in sufficient time to permit the Purchaser to be represented at the tests. If the Purchaser is not represented, the test report shall be sent to the Purchaser and shall be accepted as accurate.

8. If the acceptance tests show the Product not to be in accordance with the Contract, the Supplier shall without delay remedy any deficiencies in order to ensure that the Product complies with the Contract. New tests shall then be carried out at the Purchaser's request, unless the deficiency was insignificant.

9. The Supplier shall bear all costs for acceptance tests carried out at the place of manufacture. The Purchaser shall however bear all traveling and living expenses for his representatives in connection with such tests.

DELIVERY. PASSING OF RISK

10. Any agreed trade term shall be construed in accordance with the INCOTERMS® in force at the formation of the Contract. If no trade term has been specifically agreed, the delivery shall be Free Carrier (FCA) at the place named by the Supplier.

If, in the case of delivery Free Carrier, the Supplier, at the request of the Purchaser, undertakes to send the Product to its destination, the risk will pass not later than when the Product is handed over to the first carrier. Partial delivery shall not be permitted, unless otherwise agreed.

TIME FOR DELIVERY. DELAY

11. If the parties, instead of specifying the date for delivery, have specified a period of time within which delivery shall take place, such period shall start to run as soon as the Contract is entered into and all agreed preconditions to be fulfilled by the Purchaser have been satisfied, such as official formalities, payments due at the formation of the Contract and securities.

12. If the Supplier anticipates that he will not be able to deliver the Product at the time for delivery, he shall forthwith notify the Purchaser thereof In Writing, stating the reason and, if possible, the time when delivery can be expected. If the Supplier fails to give such notice, the Purchaser shall be entitled to compensation for any additional costs which he incurs and which he could have avoided had he received such notice.

13. If delay in delivery is caused by any of the circumstances mentioned in Clause 41, by an act or omission on the part of the Purchaser, including suspension under Clauses 21 and 44, or any other circumstances attributable to the Purchaser, the Supplier shall be entitled to extend the time for delivery by a period which is necessary having regard to all the circumstances of the case. This provision shall apply regardless of whether the reason for the delay occurs before or after the agreed time for delivery.

14. If the Product is not delivered at the time for delivery, the Purchaser shall be entitled to liquidated damages from the date on which delivery should have taken place. The liquidated damages shall be payable at a rate of 0.5 percent of the purchase price for each commenced week of delay. The liquidated damages shall not exceed 7.5 per cent of the purchase price.

If only part of the Product is delayed, the liquidated damages shall be calculated on that part of the purchase price which is attributable to such part of the Product as cannot in consequence of the delay be used as intended by the parties.

The liquidated damages shall become due at the Purchaser's demand In Writing but not before delivery has been completed or the Contract is terminated under Clause 15.

The Purchaser shall forfeit his right to liquidated damages if he has not lodged a claim In Writing for such damages within six months after the time when delivery should have taken place.

15. If the delay in delivery is such that the Purchaser is entitled to maximum liquidated damages under Clause 14 and if the Product is still not delivered, the Purchaser may In Writing demand delivery within a final reasonable period which shall not be less than one week.

If the Supplier does not deliver within such final period and this is not due to any circumstances which are attributable to the Purchaser, then the Purchaser may by notice In Writing to the Supplier terminate the Contract in respect of such part of the Product as cannot in consequence of the Supplier's failure to deliver be used as intended by the parties.

If the Purchaser terminates the Contract he shall be entitled to compensation for the loss he suffers as a result of the Supplier's delay, including any consequential and indirect loss. The total compensation, including the liquidated damages which are payable under Clause 14, shall not exceed 15 per cent of that part of the purchase price which is attributable to the part of the Product in respect of which the Contract is terminated.

The Purchaser shall also have the right to terminate the Contract by notice In Writing to the Supplier, if it is clear from the circumstances that there will occur a delay in delivery which, under Clause 14, would entitle the Purchaser to maximum liquidated damages. In case of termination for this reason, the Purchaser shall be entitled to maximum liquidated damages and compensation under the third paragraph of this Clause 15.

16. Liquidated damages under Clause 14 and termination of the Contract with limited compensation under Clause 15 shall be the only remedies available to the Purchaser in case of delay on the part of the Supplier. All other claims against the Supplier based on such delay shall be excluded, except where the Supplier has been guilty of Gross Negligence.

17. If the Purchaser anticipates that he will be unable to accept delivery of the Product at the time for delivery, he shall forthwith notify the Supplier In Writing thereof, stating the reason and, if possible, the time when he will be able to accept delivery.

If the Purchaser fails to accept delivery at the time for delivery, he shall nevertheless pay any part of the purchase price which becomes due at the time for delivery, as if delivery had taken place at the time for delivery. The Supplier shall arrange for storage of the Product at the risk and expense of the Purchaser. The Supplier shall also, if the Purchaser so requires, insure the Product at the Purchaser's expense.

18. Unless the Purchaser's failure to accept delivery is due to any such circumstance as mentioned in Clause 41, the Supplier may by notice In Writing require the Purchaser to accept delivery within a final reasonable period.

If, for any reason which is not attributable to the Supplier, the Purchaser fails to accept delivery within such period, the Supplier may by notice In Writing terminate the Contract in whole or in part. The Supplier shall then be entitled to compensation for the loss he suffers by reason of the Purchaser's default, including any consequential and indirect loss. The compensation shall not exceed that part of the purchase price which is attributable to that part of the Product in respect of which the Contract is terminated.

PAYMENT

19. Payment shall be made within 30 days after the date of invoice.

Unless otherwise agreed, the purchase price shall be paid with one third at the formation of the Contract and one third when the Supplier notifies the Purchaser that the Product, or the essential part of it, is ready for delivery. The remaining part of the purchase price shall be paid when the entire Product is delivered.

20. Whatever the means of payment used, payment shall not be deemed to have been effected before the Supplier's account has been irrevocably credited for the amount due.

21. If the Purchaser fails to pay by the stipulated date, the Supplier shall be entitled to interest from the day on which payment was due and to compensation for recovery costs. The rate of interest shall be as agreed between the parties or otherwise 8 percentage points above the rate of the main refinancing facility of the European Central Bank. The compensation for recovery costs shall be 1 per cent of the amount for which interest for late payment becomes due.

In case of late payment and in case the Purchaser fails to give an agreed security by the stipulated date the Supplier may, after having notified the Purchaser In Writing, suspend his performance of the Contract until he receives payment or, where appropriate, until the Purchaser gives the agreed security.

If the Purchaser has not paid the amount due within three months the Supplier shall be entitled to terminate the Contract by notice In Writing to the Purchaser and, in addition to the interest and compensation for recovery costs according to this Clause, to claim compensation for the loss he incurs. Such compensation shall not exceed the agreed purchase price.

RETENTION OF TITLE

22. The Product shall remain the property of the Supplier until paid for in full to the extent that such retention of title is valid under the relevant law. The Purchaser shall at the request of the Supplier assist him in taking any measures necessary to protect the Supplier's title to the Product. The retention of title shall not affect the passing of risk under Clause 10.

LIABILITY FOR DEFECTS

23. Pursuant to the provisions of Clauses 24-39, the Supplier shall remedy any defect or nonconformity (hereinafter termed defect(s)) resulting from faulty design, materials or workmanship.

24. The Supplier shall not be liable for defects arising out of materials provided or a design stipulated or specified by the Purchaser.

25. The Supplier shall only be liable for defects which appear under the conditions of operation provided for in the Contract and under proper use of the Product.

26. The Supplier shall not be liable for defects caused by circumstances, which arise after the risk has passed to the Purchaser, e.g. defects due to faulty maintenance, incorrect installation or faulty repair by the Purchaser or to alterations carried out without the Supplier's consent In Writing. The Supplier shall neither be liable for normal wear and tear nor for deterioration.

27. The Supplier's liability shall be limited to defects which appear within a period of one year from delivery. If the use of the Product exceeds that which is agreed, this period shall be reduced proportionately.

28. When a defect in a part of the Product has been remedied, the Supplier shall be liable for defects in the repaired or replaced part under the same terms and conditions as those applicable to the original Product for a period of one year. For the remaining parts of the Product the period mentioned in Clause 27 shall be extended only by a period equal to the period during which and to the extent that the Product could not be used as a result of the defect.

29. The Purchaser shall without undue delay notify the Supplier in Writing of any defect which appears. Such notice shall under no circumstances be given later than two weeks after the expiry of the period given in Clause 27 or the extended period(s) under Clause 28, where applicable. The notice shall contain a description of the defect. If the Purchaser fails to notify the Supplier In Writing of a defect within the time limits set forth in the first paragraph of this Clause, he shall lose his right to have the defect remedied. Where the defect is such that it may cause damage, the Purchaser shall immediately inform the Supplier In Writing. The Purchaser shall bear the risk of damage to the Product resulting from his failure so to notify. The Purchaser shall take reasonable measures to minimize damage and shall in that respect comply with instructions of the Supplier.

30. On receipt of the notice under Clause 29 the Supplier shall at his own cost remedy the defect without undue delay, as stipulated in Clauses 23-39. The time for remedial work shall be chosen in order not to interfere unnecessarily with the Purchaser's activities. Repair shall be carried out at the place where the Product is located unless the Supplier deems it more appropriate that the Product is sent to him or a destination specified by him.

If the defect can be remedied by replacement or repair of a defective part and if dismantling and re-installation of the part do not require special knowledge, the Supplier may demand that the defective part is sent to him or a destination specified by him. In such case the Supplier shall have fulfilled his obligations in respect of the defect when he delivers a duly repaired part or a part in replacement to the Purchaser.

31. The Purchaser shall at his own expense provide access to the Product and arrange for any intervention in equipment other than the Product, to the extent that this is necessary to remedy the defect.

32. Unless otherwise agreed, necessary transport of the Product or parts thereof to and from the Supplier in connection with the remedying of defects for which the Supplier is liable shall be at the risk and expense of the Supplier. The Purchaser shall follow the Supplier's instructions regarding such transport.

33. Unless otherwise agreed, the Purchaser shall bear any additional costs which the Supplier incurs for remedying the defect caused by the Product being located in a place other than the destination stated at the formation of the Contract for the Supplier's delivery to the Purchaser or – if no destination has been stated – the place of delivery.

34. Defective parts which have been replaced shall be made available to the Supplier and shall be his property.

35. If the Purchaser has given such notice as mentioned in Clause 29 and no defect is found for which the Supplier is liable, the Supplier shall be entitled to compensation for the costs he incurs as a result of the notice.

36. If the Supplier does not fulfill his obligations under Clause 30, the Purchaser may by notice In Writing fix a final reasonable period for completion of the Supplier's obligations, which shall not be less than one week. If the Supplier fails to fulfill his obligations within such final period, the Purchaser may himself undertake or employ a third party to undertake necessary repair work at the risk and expense of the Supplier.

Where successful repair work has been undertaken by the Purchaser or a third party, reimbursement by the Supplier of reasonable costs incurred by the Purchaser shall be in full settlement of the Supplier's liabilities for the said defect.

37. Where the Product has not been successfully repaired, as stipulated under Clause 36,
a) the Purchaser shall be entitled to a reduction of the purchase price in proportion to the reduced value of the Product, provided that under no circumstances shall such reduction exceed 15 per cent of the purchase price, or
b) where the defect is so substantial as to significantly deprive the Purchaser of the benefit of the Contract as regards the Product or a substantial part of it, the Purchaser may terminate the Contract by notice In Writing to the Supplier in respect of such part of the Product as cannot in consequence of the defect be used as intended by the parties. The Purchaser shall then be entitled to compensation for his loss, costs and damages up to a maximum of 15 per cent of that part of the purchase price which is attributable to the part of the Product in respect of which the Contract is terminated.

38. Notwithstanding the provisions of Clauses 23-37 the Supplier shall not be liable for defects in any part of the Product for more than one year from the end of the liability period referred to in Clause 27 or from the end of any other liability period agreed upon by the parties.

39. Save as stipulated in Clauses 23-38, the Supplier shall not be liable for defects. This applies to any loss the defect may cause including loss of production, loss of profit and other indirect loss. This limitation of the Supplier's liability shall not apply if he has been guilty of Gross Negligence.

ALLOCATION OF LIABILITY FOR DAMAGE CAUSED BY THE PRODUCT

40. The Supplier shall not be liable for any damage to property caused by the Product after it has been delivered and whilst it is in the possession of the Purchaser. Nor shall the Supplier be liable for any damage to products manufactured by the Purchaser or to products of which the Purchaser's products form a part.

If the Supplier incurs liability towards any third party for such damage to property as described in the preceding paragraph, the Purchaser shall indemnify, defend and hold the Supplier harmless.

If a claim for damage as described in this Clause is lodged by a third party against one of the parties, the latter party shall forthwith inform the other party thereof In Writing.

The Supplier and the Purchaser shall be mutually obliged to let themselves be summoned to the court or arbitral tribunal examining claims for damages lodged against one of them on the basis of damage allegedly caused by the Product. The liability between the Supplier and the Purchaser shall however be settled in accordance with Clause 46.

The limitation of the Supplier's liability in the first paragraph of this Clause shall not apply where the Supplier has been guilty of Gross Negligence.

FORCE MAJEURE

41. Either party shall be entitled to suspend performance of his obligations under the Contract to the extent that such performance is impeded or made unreasonably onerous by Force Majeure, meaning any of the following circumstances: industrial disputes and any other circumstance beyond the control of the parties such as fire, war, extensive military mobilization, insurrection, requisition, seizure, embargo, restrictions in the use of power, currency and export restrictions, epidemics, natural disasters, extreme natural events, terrorist acts and defects or delays in deliveries by sub-contractors caused by any such circumstance referred to in this Clause.

A circumstance referred to in this Clause whether occurring prior to or after the formation of the Contract shall give a right to suspension only if its effect on the performance of the Contract could not be foreseen at the time of the formation of the Contract.

42. The party claiming to be affected by Force Majeure shall notify the other party In Writing without delay on the intervention and on the cessation of such circumstance. If a party fails to give such notice, the other party shall be entitled to compensation for any additional costs which he incurs and which he could have avoided had he received such notice.

If Force Majeure prevents the Purchaser from fulfilling his obligations, he shall compensate the Supplier for expenses incurred in securing and protecting the Product.

43. Regardless of what might otherwise follow from these General Conditions, either party shall be entitled to terminate the Contract by notice In Writing to the other party if performance of the Contract is suspended under Clause 41 for more than six months.

ANTICIPATED NON-PERFORMANCE

44. Notwithstanding other provisions in these General Conditions regarding suspension, each party shall be entitled to suspend the performance of his obligations under the Contract, where it is clear from the circumstances that the other party is not going to perform his obligations. A party suspending his performance of the Contract shall forthwith notify the other party thereof In Writing.

CONSEQUENTIAL LOSSES

45. Save as otherwise stated in these General Conditions there shall be no liability for either party towards the other party for loss of production, loss of profit, loss of use, loss of contracts or for any other consequential or indirect loss whatsoever.

DISPUTES AND APPLICABLE LAW

46. All disputes arising out of or in connection with the Contract shall be finally settled under the Rules of Arbitration of the International Chamber of Commerce by one or more arbitrators appointed in accordance with the said Rules.

47. The Contract shall be governed by the substantive law of the Supplier's country.

This is an Orgalime publication. Orgalime represents the mechanical, electrical, electronic and metalworking industries in Europe.

All rights reserved ©

Editeur responsable : Adrian Harris, Director General

ORGALIME – The European Engineering Industries Association

Diamant Building, Boulevard A Reyers 80, B-1030 Brussels

Tel: +32 2 706 82 35 – Fax: +32 2 706 82 50 – secretariat@orgalime.org – www.orgalime.org

PRÉAMBULE

1. Les présentes Conditions Générales sont applicables sous réserve de l'accord des parties, qu'il soit donné Par Écrit ou autrement. Toute modification ou dérogation de celles-ci doit être acceptée Par Écrit.

DÉFINITIONS

2. Dans les présentes Conditions Générales, les termes ci-dessous sont définis comme suit :

- « Contrat » : l'accord Par Écrit entre les parties concernant la fourniture des Produits et tous ses accessoires, y compris les modifications et ajouts dans les documents concernés;
- « Faute Lourde » : tout acte ou omission impliquant soit un défaut d'attention caractérisé à des conséquences graves pouvant en résulter et qu'un contractant diligent aurait normalement prévues, ou tout défaut délibéré de prise en compte des conséquences d'un tel acte ou d'une telle omission;
- « Par Écrit » : communication par document signé par chacune des parties ou par courrier, télécopie, courriel ou par tout autre moyen convenu par les parties;
- « le Produit » : l'(les) objet(s) à être fourni(s) au titre du contrat, logiciels et documentation inclus.

INFORMATION SUR LE PRODUIT

3. Les renseignements et informations concernant le Produit contenus dans les catalogues et tarifs, ne sont contractuels que dans la mesure où ils sont inclus Par Écrit dans le Contrat par une référence expresse.

PLANS ET INFORMATIONS TECHNIQUES

4. Tous les plans et documents techniques relatifs au Produit ou à sa fabrication, qui ont été soumis par une partie à l'autre partie avant ou après la conclusion du Contrat, demeurent la propriété de la partie qui les a remis. Les plans, documents techniques et toute autre information technique reçus par une partie ne seront pas utilisés, sans l'accord de l'autre partie, à d'autres fins que celles pour lesquelles ils ont été prévus. Sans le consentement de la partie qui les soumet, ils ne peuvent être utilisés à d'autres fins ou copiés, reproduits, transmis ou communiqués à un tiers.

5. Le Fournisseur doit fournir gratuitement à l'Acheteur, pas plus tard qu'à la date de livraison, l'information et les documents nécessaires pour permettre à ce dernier d'installer, de faire la réception, d'exploiter et d'entretenir le Produit. Cette information et ces documents sont fournis en un nombre d'exemplaires qui est défini d'un commun accord ou en au moins deux exemplaires. Le Fournisseur n'est pas tenu de fournir les schémas de fabrication du Produit ou des pièces détachées.

ESSAIS DE RÉCEPTION

6. Sauf stipulations différentes, les essais de réception prévus au Contrat, doivent se dérouler sur le lieu de fabrication, aux heures normales de travail. Si le Contrat ne stipule aucune exigence technique, les essais de réception se dérouleront conformément à la pratique générale en vigueur dans la branche d'industrie concernée du pays de fabrication.

7. Suffisamment en avance pour lui permettre d'être représenté, le Fournisseur notifie les essais de réception à l'Acheteur Par Écrit. Si l'Acheteur n'est pas représenté, les rapports d'essais seront adressés à l'Acheteur et seront acceptés comme probants.

8. Si les rapports d'essais prouvent que le Produit n'est pas conforme au Contrat, le Fournisseur doit, sans délai, remédier aux défauts afin de mettre le Produit en conformité avec le Contrat. De nouveaux essais seront alors effectués à la demande de l'Acheteur sauf si le défaut n'est pas significatif.

9. Le Fournisseur supporte les coûts des essais de réception effectués sur le lieu de fabrication. L'Acheteur supporte toutefois les frais de déplacement de ses représentants durant les essais.

LIVRAISON – TRANSFERT DES RISQUES

10. Les conditions de livraison convenues sont interprétées conformément aux INCOTERMS® en vigueur à la date de conclusion du Contrat. Si aucune condition de livraison particulière n'a été convenue, la livraison a lieu Franco transporteur ou « Free Carrier » (FCA) au lieu désigné par le Fournisseur. Si, dans le cas de livraison Franco transporteur, et à la demande de l'Acheteur, le Fournisseur s'engage à expédier le Produit à sa destination, le transfert des risques a lieu au plus tard lors de la remise du Produit au premier transporteur. Des expéditions partielles ne sont pas admises, sauf stipulations contraires.

DATE DE LIVRAISON - RETARD

11. Si, au lieu de stipuler une date de livraison, les parties ont stipulé un délai à l'expiration duquel la livraison doit avoir lieu, ce délai court à compter du jour où le Contrat est entré en vigueur, et où toutes les conditions préalables à la charge de l'Acheteur ont été respectées, telles que des formalités officielles, les paiements dus à la conclusion du Contrat et les garanties.

12. Si le Fournisseur prévoit qu'il ne pourra livrer le Produit dans le délai convenu, il doit le notifier immédiatement, Par Écrit à l'Acheteur, en indiquant le motif et si possible la date prévisible de livraison. En cas de manquement du Fournisseur à l'obligation de notification, l'Acheteur est en droit de recevoir une compensation pour les coûts additionnels qu'il a subis et qu'il aurait pu éviter s'il avait reçu la notification.

13. Si le retard de livraison est causé par un événement mentionné à la Clause 41 ou en raison d'un acte ou d'une omission imputable à l'Acheteur, y compris la suspension du Contrat en application des Clauses 21 et 44, ou toute autre circonstance imputable à l'Acheteur, le Fournisseur sera en droit de repousser la date de livraison d'un délai nécessaire compte tenu de toutes les circonstances. Cette disposition s'applique, que la cause du retard se soit manifestée avant ou après la date à laquelle la livraison aurait dû avoir lieu.

14. Si le Produit n'est pas livré à la date prévue, l'Acheteur a droit à des dommages-intérêts pour retard à compter de la date de livraison contractuelle. Les dommages-intérêts pour retard sont payables à un taux de 0,5 % du prix d'achat pour chaque semaine commencée de retard. Les dommages-intérêts pour retard ne pourront excéder 7,5 % du prix d'achat. Si c'est une partie du Produit dont la livraison est retardée, les dommages-intérêts pour retard sont calculés sur la partie du prix d'achat du Produit relative à l'élément qui, en raison du retard, ne peut être utilisé comme convenu. Les dommages-intérêts pour retard sont dus à compter de la demande Par Écrit formulée par l'Acheteur mais pas avant que la livraison ne soit achevée ou le Contrat résilié en application de la Clause 15.

L'Acheteur perd son droit à des dommages-intérêts pour retard s'il n'en fait pas la demande écrite dans les six mois qui suivent la date à laquelle la livraison aurait dû avoir lieu.

15. Si le retard de livraison est tel que l'Acheteur a droit au maximum des dommages-intérêts en vertu de la Clause 14 et si le Produit n'est toujours pas livré, l'Acheteur peut Par Écrit exiger une livraison dans un délai raisonnable ultime qui ne sera pas inférieur à une semaine. Si le Fournisseur n'effectue pas la livraison dans cet ultime délai et sauf dans des circonstances imputables à l'Acheteur, celui-ci peut, par notification adressée Par Écrit au Fournisseur, résilier le Contrat pour la partie du Produit qui, en raison de la défaillance du Fournisseur, ne peut être utilisée comme convenu. En cas de résiliation du Contrat par l'Acheteur, ce dernier a droit à être indemnisé pour les dommages qu'il subit du fait du retard du Fournisseur, y compris tout dommage direct et indirect. Le montant total de cette indemnisation y compris les dommages-intérêts pour retard prévus à la Clause 14, n'excédera pas 15 % du prix d'achat correspondant à la partie du Produit, objet de la résiliation. L'Acheteur a également le droit de résilier le Contrat par notification Par Écrit au Fournisseur, s'il résulte de façon patente de toutes les circonstances, qu'un retard se produira dans la livraison lui permettant, conformément à la Clause 14, d'obtenir le maximum des dommages-intérêts. En cas de résiliation pour ce motif, l'Acheteur a droit au maximum des dommages-intérêts pour retard et à l'indemnisation stipulée au 3ème paragraphe de la présente Clause 15.

16. Les dommages-intérêts prévus par la Clause 14 et l'indemnisation accompagnant la résiliation prévue par la Clause 15, sont les seuls recours dont dispose l'Acheteur, en cas de retard du Fournisseur. Toute autre réclamation fondée sur ce retard est exclue, sauf Faute Lourde imputable au Fournisseur.

17. Si l'Acheteur prévoit qu'il ne pourra accepter la livraison du Produit à la date de livraison, il doit en avertir immédiatement le Fournisseur Par Écrit en lui indiquant le motif et si possible la date à laquelle il sera en mesure d'accepter la livraison. Si l'Acheteur reste en défaut d'accepter la livraison, à la date de livraison, il doit toutefois payer la partie du prix qui est payable comme si la livraison avait eu lieu. Le Fournisseur prendra toute disposition aux frais et risques de l'Acheteur pour stocker le Produit. À la demande de l'Acheteur, le Fournisseur fera également assurer le Produit aux frais de l'Acheteur.

18. Sauf si l'Acheteur est empêché de procéder à la réception de la livraison pour un motif relevant de la Clause 41, le Fournisseur peut, Par Écrit, mettre en demeure l'Acheteur d'avoir à réceptionner la livraison dans un ultime délai raisonnable. Si, pour un motif qui n'est pas imputable au Fournisseur, l'Acheteur ne réceptionne pas la livraison dans ce délai, le Fournisseur peut, Par Écrit, résilier le Contrat en totalité ou en partie. Le Fournisseur est en droit d'être indemnisé pour les pertes qu'il a subies du fait de la défaillance de l'Acheteur, y compris pour les dommages directs et indirects. Cette indemnisation ne doit pas excéder le prix d'achat de la partie du Produit soumise à la résiliation.

PAIEMENT

19. Les paiements sont effectués dans les 30 jours de la date de la facture. Sauf stipulations différentes, un tiers du prix est payable à la conclusion du Contrat et un tiers à la notification par le Fournisseur à l'Acheteur que le Produit ou une partie essentielle de celui-ci est mis à sa disposition pour livraison. Le paiement du solde du prix a lieu lorsque le Produit a fait l'objet d'une livraison complète.

20. Quel que soit le moyen de paiement utilisé, tout paiement n'est pas considéré comme effectué tant que le compte du Fournisseur n'est pas irrévocablement crédité de la somme due.

21. Si à la date stipulée l'Acheteur n'a pas payé, le Fournisseur a droit à des intérêts moratoires, à compter du jour où le paiement devait être effectué, ainsi qu'à une indemnité pour frais de recouvrement. Le taux de ceux-ci est celui qui aura été convenu entre les parties et à défaut, celui du refinancement de la Banque centrale européenne majoré de 8 points. L'indemnité pour frais de recouvrement sera de 1 pour cent de la somme pour laquelle l'intérêt de retard est dû. En cas de paiement retardé, et dans le cas où l'Acheteur ne remet pas la garantie de paiement convenue à la date stipulée, le Fournisseur peut, après en avoir averti l'Acheteur Par Écrit, suspendre l'exécution du Contrat jusqu'à réception du paiement ou, le cas échéant, jusqu'à la remise par l'Acheteur de la garantie convenue. Si dans les trois mois l'Acheteur n'a pas payé le montant dû, le Fournisseur est en droit, par notification Par Écrit adressée à l'Acheteur, de résilier le Contrat et de demander, outre les intérêts et l'indemnité pour frais de recouvrement prévus à la présente Clause, à être indemnisé des pertes qu'il subit. Cette indemnisation ne doit pas excéder le prix d'achat convenu.

RÉSERVE DE PROPRIÉTÉ

22. Le Produit demeure la propriété du Fournisseur jusqu'à complet paiement de son prix, dans la mesure où cette réserve de propriété est valable au regard du droit concerné. À la demande du Fournisseur, l'Acheteur assiste le Fournisseur dans la prise des mesures nécessaires pour protéger la propriété du Fournisseur sur le Produit. La réserve de propriété ne modifie pas le transfert des risques tel que prévu à la Clause 10.

RESPONSABILITÉ POUR DÉFAUTS

23. Le Fournisseur s'engage à réparer tout défaut ou non conformité (ci-après qualifié de "défaut(s)") résultant d'un défaut de conception, de matière ou de fabrication dans les conditions définies aux Clauses 24 à 39.

24. Le Fournisseur n'est pas responsable des défauts résultant des matières fournies ou d'une conception stipulée ou spécifiée par l'Acheteur.

25. Le Fournisseur ne sera responsable des défauts que dans la mesure des conditions d'utilisation contractuelles et d'une utilisation normale du Produit.

26. Le Fournisseur ne sera pas responsable des défauts causés par des circonstances apparaissant après le transfert des risques à l'Acheteur, tels que des défauts dus à une maintenance fautive, une installation incorrecte ou une réparation fautive par l'Acheteur, ou des altérations apportées sans l'accord Par Écrit du Fournisseur. Le Fournisseur ne sera pas non plus responsable des détériorations résultant de l'usage normal.

27. La responsabilité du Fournisseur est limitée aux défauts qui apparaissent dans le délai d'un an suivant la livraison. Cette période sera proportionnellement réduite si l'usage quotidien du Produit excède celui qui est convenu.

28. Après que le défaut d'une partie du Produit ait été réparé, le Fournisseur garantit la pièce réparée ou remplacée pendant un an dans les mêmes conditions que s'il s'agissait du Produit lui-même. Pour les autres parties du Produit, la période mentionnée à la Clause 27 est étendue de la durée pendant laquelle, et dans la mesure où, le Produit n'a pas pu être utilisé en raison du défaut.

29. L'Acheteur doit notifier Par Écrit le défaut sans délai au Fournisseur dès qu'il apparaît. En aucun cas, cette notification ne doit être émise plus de deux semaines après l'expiration de la période mentionnée à la Clause 27 ou de la période étendue définie à la Clause 28 lorsqu'elle est applicable. La notification doit comprendre une description du défaut. Si l'Acheteur ne notifie pas Par Écrit le défaut au Fournisseur, dans le délai mentionné au premier paragraphe de la présente Clause, il perd son droit à la réparation du défaut. Dans le cas où le défaut est tel qu'il risque de provoquer un dommage, l'Acheteur doit en informer immédiatement le Fournisseur Par Écrit. L'Acheteur supporte le risque de dommages au Produit résultant d'une absence de notification. L'Acheteur doit prendre les mesures raisonnables afin de minimiser le dommage et devra à cet égard agir conformément aux instructions du Fournisseur.

30. Dès réception de la notification conformément à la Clause 29, le Fournisseur, à ses frais, remédie aussi vite que possible au défaut, dans les conditions des Clauses 23 à 39. Le moment de cette intervention corrective sera choisi dans le but de ne pas interférer inutilement sur l'activité de l'Acheteur. Les réparations sont effectuées à l'endroit où se trouve le Produit, à moins que le Fournisseur ne juge plus approprié que le Produit lui soit envoyé ou soit envoyé à une destination qu'il aura spécifiée. Dans le cas où il peut être remédié au défaut d'une pièce défectueuse par son remplacement ou sa réparation et si son démontage et son remontage ne nécessite pas une compétence

particulière, le Fournisseur pourra demander que la pièce défectueuse lui soit expédiée, ou soit expédiée à une destination spécifiée par lui. Dans un tel cas, le Fournisseur aura rempli son obligation par rapport au défaut, en livrant à l'Acheteur une pièce réparée ou de remplacement.

31. Dans la mesure où cela est nécessaire à la réparation du défaut, l'Acheteur permettra l'accès au Produit et fera son affaire de toute intervention sur des équipements autres que le Produit.

32. Sauf stipulations différentes, le Fournisseur supporte les risques et les frais consécutifs au transport aller et retour du Produit et/ou des pièces, liés à la réparation des défauts dont le Fournisseur est responsable. Pour ce transport, l'Acheteur doit suivre les instructions données par le Fournisseur.

33. Sauf stipulations différentes, l'Acheteur supporte les coûts additionnels encourus pour remédier au défaut causé par le Produit dans un lieu autre que la destination convenue lors de la formation du Contrat ou que le lieu de livraison, en l'absence d'une telle mention.

34. Les pièces défectueuses remplacées sont mises à la disposition du Fournisseur et sont sa propriété.

35. Si l'Acheteur a procédé à la notification mentionnée à la Clause 29 et qu'aucun défaut dont le Fournisseur est responsable n'a été identifié, le Fournisseur aura droit à une indemnisation pour les coûts qu'il aura supportés en conséquence de cette notification.

36. Si le Fournisseur n'a pas rempli ses obligations découlant de la Clause 30, l'Acheteur peut, par notification Par Écrit, fixer un délai final raisonnable pour l'accomplissement par le Fournisseur de ses obligations, qui ne peut être inférieur à une semaine. Si le Fournisseur ne remplit pas ses obligations dans ce délai final, l'Acheteur peut procéder ou faire procéder par un tiers aux opérations de réparation nécessaires, aux frais et risques du Fournisseur.

Si ces opérations de réparation ont été menées avec succès par l'Acheteur ou par un tiers, le remboursement par le Fournisseur des coûts raisonnables supportés par l'Acheteur, vaudra pleine et entière décharge des obligations encourues par le Fournisseur du fait du dit défaut.

37. Si la réparation du Produit n'a pas été effectuée avec succès, comme il est stipulé à la Clause 36 :

- a) l'Acheteur a droit à une réduction du prix d'achat proportionnellement à la diminution de valeur du Produit, pourvu qu'en aucune circonstance une telle réduction n'excède 15 % du prix d'achat, ou
- b) si le défaut est d'une importance telle qu'elle prive l'Acheteur, de façon significative, du bénéfice du Contrat en ce qui concerne le Produit ou une partie substantielle de celui-ci, l'Acheteur peut résilier le Contrat par notification Par Écrit adressée au Fournisseur dans la mesure de la partie du Produit qui ne peut, du fait du défaut, être utilisé comme les parties en avaient convenu. L'Acheteur est alors en droit d'obtenir une compensation pour ses pertes, coûts et dommages dans la limite maximum de 15 % de la partie du prix d'achat correspondant à la partie du Produit au titre duquel le contrat est résilié.

38. Nonobstant les dispositions des Clauses 23 à 37, le Fournisseur est déchargé de toute responsabilité pour tout défaut du Produit, au bout d'un an à compter de la fin de la durée de responsabilité mentionnée dans la Clause 27 ou à compter de la fin de toute autre durée de responsabilité convenue entre les parties.

39. La responsabilité du Fournisseur pour les défauts est limitée aux stipulations des Clauses 23 à 38. Cette limitation exclut la réparation de tout autre dommage résultant du défaut, y compris pertes de production, pertes de bénéfice et tout autre dommage indirect. Cette limitation ne s'applique pas en cas de Faute Lourde.

PARTAGE DES RESPONSABILITÉS EN CAS DE DOMMAGE DU FAIT DU PRODUIT

40. Le Fournisseur n'est responsable d'aucun dommage aux biens du fait du Produit après sa livraison dès que l'Acheteur en a pris possession. De la même façon, le Fournisseur n'est pas responsable ni des dommages causés aux produits fabriqués par l'Acheteur, ni aux produits incorporant ceux de l'Acheteur. Si le Fournisseur encourt une responsabilité à l'égard d'un tiers pour des dommages aux biens tels que décrits ci-dessus, l'Acheteur est tenu d'indemniser, de défendre et de garantir le Fournisseur. Si une action en dommages-intérêts, sur les fondements décrits dans la présente Clause, est introduite par un tiers contre l'une des parties, celle-ci en informera immédiatement l'autre partie Par Écrit. Le Fournisseur et l'Acheteur doivent se laisser attraire devant le tribunal ou l'instance arbitrale jugeant l'action en dommages-intérêts introduite sur le fondement d'un dommage prétendument causé par le Produit. Toutefois, les questions relatives à la responsabilité entre le Fournisseur et l'Acheteur seront réglées conformément à la Clause 46. La limitation de responsabilité du Fournisseur résultant du 1er paragraphe de cette Clause ne s'applique pas en cas de Faute Lourde du Fournisseur.

42. La partie qui demande l'application de la Force Majeure doit notifier sans délai, Par Écrit, à l'autre partie le début et la fin de la circonstance ainsi qualifiée. Si une partie manque à son obligation de faire une telle notification, l'autre partie aura droit à une indemnisation pour tous les coûts supplémentaires qui en résultent et qu'elle aurait pu éviter si elle avait reçu cette notification. Si la Force Majeure empêche l'Acheteur de remplir ses obligations, il devra indemniser le Fournisseur des coûts résultant de la protection et de la mise en sécurité du Produit.

43. Quelle que soit la conséquence qui en résulterait dans les présentes Conditions Générales, chaque partie est en droit de résilier le Contrat, par une notification Par Écrit adressée à l'autre partie, si l'exécution du Contrat est suspendue du fait de la Clause 41 pendant plus de six mois.

INEXÉCUTION ANTICIPÉE

44. Nonobstant les autres stipulations de ces Conditions Générales concernant la suspension, chaque partie a le droit de suspendre l'exécution de ses obligations résultant du Contrat lorsqu'il résulte clairement des circonstances que l'autre partie ne va pas exécuter ses obligations. Une partie suspendant l'exécution de ses obligations résultant du Contrat doit aussitôt le notifier Par Écrit à l'autre partie.

DOMMAGES INDIRECTS

45. Sauf stipulations différentes des présentes Conditions Générales, aucune partie ne sera responsable à l'égard de l'autre, des pertes de production, pertes de profit, pertes d'usage, pertes de contrats ou de tout autre dommage ou pertes indirectes quels qu'ils soient.

LITIGES ET LOI APPLICABLE

46. Tous différends découlant du Contrat ou en relation avec celui-ci, seront tranchés définitivement suivant le Règlement d'Arbitrage de la Chambre de Commerce Internationale par un ou plusieurs arbitres nommés conformément à ce Règlement.

47. Le Contrat est soumis à la loi de fond du pays du Fournisseur.

Ceci est une publication Orgalime. Orgalime regroupe les associations européennes des secteurs mécanique, électrique, électronique et de la transformation des métaux.

ous droits réservés ©

Editeur responsable : Adrian Harris, Directeur général

ORGALIME – The European Engineering Industries Association

Diamant Building, Boulevard A Reyers 80, B-1030 Brussels

Tel: +32 2 706 82 35 – Fax: +32 2 706 82 50 – secretariat@orgalime.org – www.orgalime.org

KATALOG 2016

Hofmann Gastronomiegeräte

Brunckstrasse 19
D-67346 Speyer

Tel. +49 6232 695 26771
+49 6232 695 26772

Fax. +49 6232 644 433

E-mail. info@mghofmann.de
www.mghofmann.de